

Excellent Integrated System Limited

Stocking Distributor

Click to view price, real time Inventory, Delivery & Lifecycle Information:

[Pomona Electronics](#)
[5777](#)

For any questions, you can email us directly:

sales@integrated-circuit.com

Pomona®

Models 5777, 5780, 5783, 5885, 5886 & 5887 JEDEC Test Clips Lead Pitch .025" Sq. Pins on .100" X .100"

These new test clips provide the user with an easy means to connect instrumentation to the fine pitch plastic QFP chip leads.

- Interfaces with high density JEDEC PQFP chip leads.
- Included are two templates for pin numbering. Both pin 1 center and pin 1 top left are included.
- PCB has ground plane which is connected to the four NC pins, (one at each corner).
- Gold plated contacts for the chip leads and the connector pins assure noise free connection.

Pomona's JEDEC test clips are perfect for system design, field service testing, failure analysis, and well suited for use with logic analyzers.

The patented locking mechanism holds the clip on the device by gripping the chip body at the end of each lead pattern. Each contact is individually cantilevered to assure positive contact. Three other types of interfaces are available for connection to your instruments. See Pomona's full line catalog for complete details. Other clips are available in many sizes to fit the most popular chips now in use.

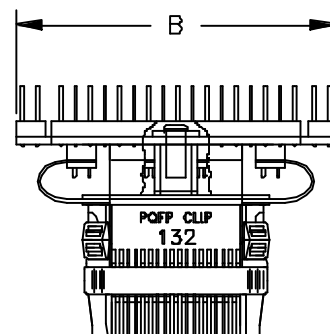
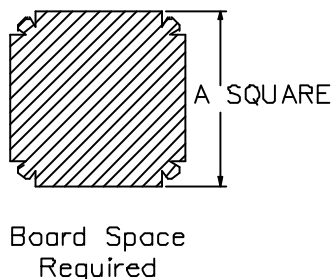
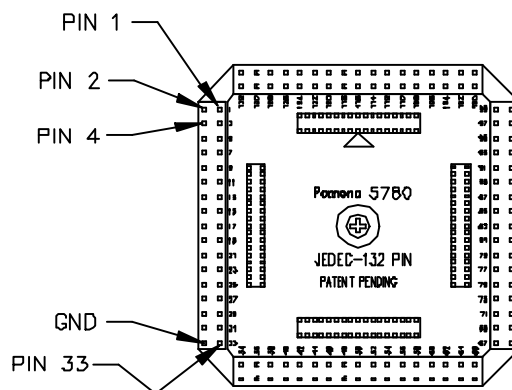

Model Number	No. of Pins	Board Footprint (A)	Minimum Space c.c. (B)	Model Number	No. of Pins	Board Footprint (A)	Minimum Space c.c. (B)
5777	100	1.00"	1.80"	5885	68	.78"	1.80"
5780	132	1.18"	2.20"	5886	84	1.20"	1.70"
5783	196	1.65"	3.00"	5887	164	1.35"	2.65"

All dimensions are in inches. Tolerances (except noted): .xx = ±.02" (.51 mm), .xxx = ±.005" (.127 mm).
 All specifications are to the latest revisions. Specifications are subject to change without notice.
 Registered trademarks are the property of their respective companies.

Made in USA