

Excellent Integrated System Limited

Stocking Distributor

Click to view price, real time Inventory, Delivery & Lifecycle Information:

[Pomona Electronics](#)
[5830-0](#)

For any questions, you can email us directly:

sales@integrated-circuit.com

Pomona®

Model 5830 Flexible Maxigrabber® Test Clip

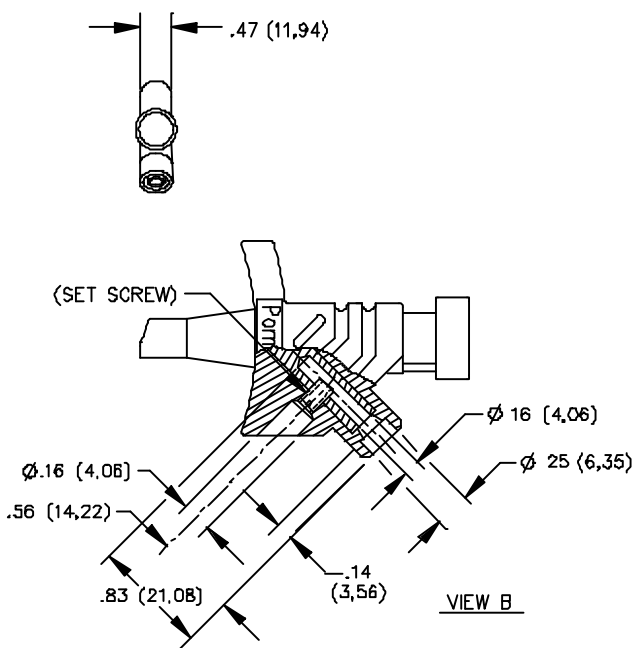
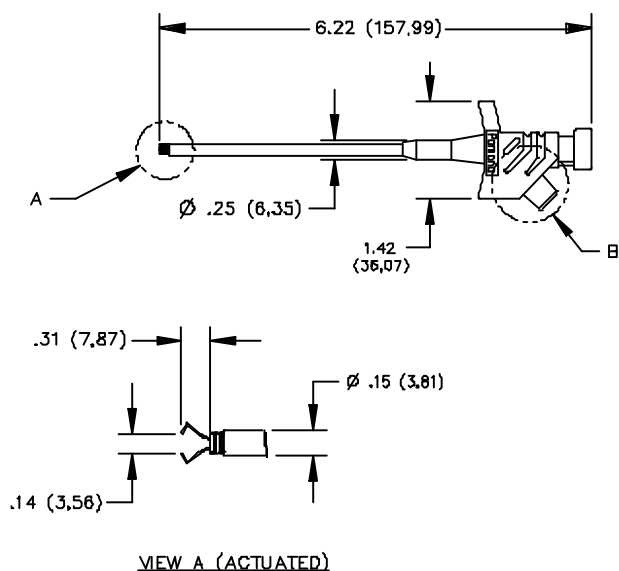

FEATURES:

- Mates to Model #1440, 4702 and most standard banana plugs.
- Use set screw to build custom cable with Pomona "Do It Yourself" products.
- Accepts 18 to 22 AWG wire (for custom cable).
- This flexible clip has a rotating pincer type contact to make access easier.
- Standard banana jack and screw for direct wire termination.

MATERIALS:

Wire: Steel.

Insulation: Thermoplastic (handle and knob)

Color: Black (heat shrink tube)

RATINGS:

Environmental:

Operating Temperature: +80°C. (+176°F.) Max.

Electrical:

Operating Voltage: 300 VRMS/DC

Current: 5 Amperes

Mechanical:

Grip: Up to \varnothing .157 (4.0).

ORDERING INFORMATION: Model 5830-*

*= Color, -0 Black, -2 Red

Ordering Example: 5830-2 Color is Red

All dimensions are in inches. Tolerances (except noted): .xx = \pm .02" (.51 mm), .xxx = \pm .005" (.127 mm).

All specifications are to the latest revisions. Specifications are subject to change without notice.

Registered trademarks are the property of their respective companies. Made in USA