

Excellent Integrated System Limited

Stocking Distributor

Click to view price, real time Inventory, Delivery & Lifecycle Information:

[Pomona Electronics](#)
[6152](#)

For any questions, you can email us directly:

sales@integrated-circuit.com

Pomona®

Model 6152 176 Pi TQFP Test Clip 0.50mm Lead Pitch

This new TQFP test clip provides the user with an easy means to connect test instruments to fine pitch plastic TQFP and SQFP chip leads.

- Connects to high-density plastic TQFP or SQFP surface mounted chip leads.
- Locking feature insures positive retention on the chip in either vertical or horizontal position.
- Gold plated contacts for the chip leads and the connector pins assure noise free connection.

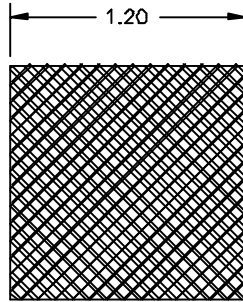

Keep Out Area

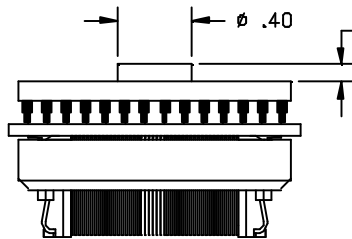
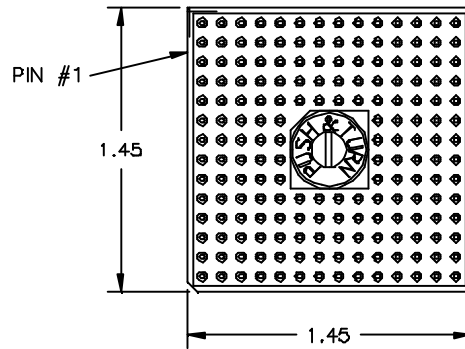

UNLOCKED - UP

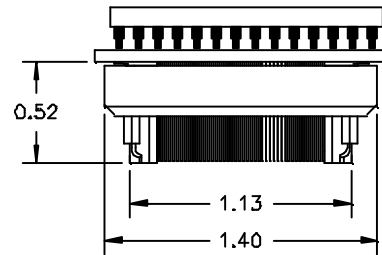

LOCKED - DOWN

Pomona's TQFP test clips are perfect for system design, field service testing, failure analysis, and for use with logic analyzers.

The patented locking mechanism holds the clip on the device by gripping the chip body at the corners of the chip body. The clip contacts are manufactured by a patented process that assures alignment.

Other clips are available in many common sizes to fit the most popular JEDEC and EIAJ packages now in use. See Pomona's full line catalog for complete details.

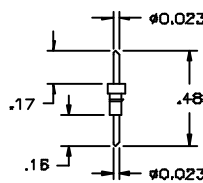

PGA Socket Adapter Pin

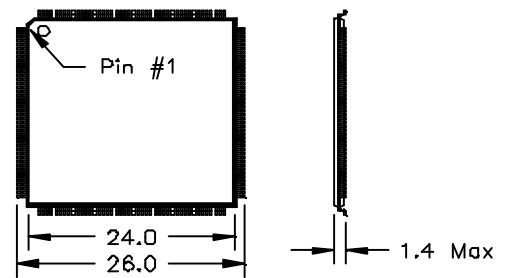

176 Pin TQFP (Typical)
(Dimensions in mm)

All dimensions are in inches. Tolerances (except noted): .xx = ±.02" (.51 mm), .xxx = ±.005" (.127 mm). All specifications are to the latest revisions. Specifications are subject to change without notice. Registered trademarks are the property of their respective companies. Made in USA

Pomona®

Model 6152
176 Pi TQFP Test Clip
0.50mm Lead Pitch

PGA Socket Layout with QFP Leads

14	-	176	175	171	166	161	156	151	146	141	136	134	133	-
13	1	6	174	172	167	162	157	152	147	142	137	135	138	132
12	2	3	7	173	168	163	158	153	148	144	140	139	130	131
11	4	5	8	11	170	165	160	155	150	145	143	129	128	127
10	9	10	12	13	17	169	164	159	154	149	126	124	123	122
9	14	15	16	18	22					125	121	119	118	117
8	19	20	21	23	27					120	116	114	113	112
7	24	25	26	28	32					115	111	109	108	107
6	29	30	31	33	37					110	106	104	103	102
5	34	35	36	38	61	66	71	76	81	105	101	100	98	97
4	39	40	41	55	57	62	67	72	77	82	99	96	93	92
3	43	42	51	52	56	60	65	70	75	80	85	95	91	90
2	44	50	47	49	54	59	64	69	74	79	84	86	94	89
1	-	45	46	48	53	58	63	68	73	78	83	87	88	-
	A	B	C	D	E	F	G	H	J	K	L	M	N	P

All dimensions are in inches. Tolerances (except noted): .xx = ±.02" (.51 mm), .xxx = ±.005" (.127 mm).
 All specifications are to the latest revisions. Specifications are subject to change without notice.
 Registered trademarks are the property of their respective companies. Made in USA