

Excellent Integrated System Limited

Stocking Distributor

Click to view price, real time Inventory, Delivery & Lifecycle Information:

[Texas Instruments](#)
[UC2832TDWEP](#)

For any questions, you can email us directly:

sales@integrated-circuit.com

UC2832-EP PRECISION LOW DROPOUT LINEAR CONTROLLER

SGLS147A – JANUARY 2003 – REVISED MARCH 2003

- **Controlled Baseline**
 - One Assembly/Test Site, One Fabrication Site
- **Extended Temperature Performance of –40°C to 105°C**
- **Enhanced Diminishing Manufacturing Sources (DMS) Support**
- **Enhanced Product Change Notification**
- **Qualification Pedigree†**
- **Precision 1% Reference**
- **Over-Current Sense Threshold Accurate to 5%**
- **Programmable Duty-Ratio Over-Current Protection**
- **4.5 V to 36 V Operation**
- **100 mA Output Drive, Source or Sink**
- **Under-Voltage Lockout**
- **Adjustable Current Limit to Current Sense Ratio**
- **Separate +V_{IN} terminal**
- **Programmable Driver Current Limit**
- **Access to VREF and E/A(+)**
- **Logic-Level Disable Input**

† Component qualification in accordance with JEDEC and industry standards to ensure reliable operation over an extended temperature range. This includes, but is not limited to, Highly Accelerated Stress Test (HAST) or biased 85/85, temperature cycle, autoclave or unbiased HAST, electromigration, bond intermetallic life, and mold compound life. Such qualification testing should not be viewed as justifying use of this component beyond specified performance and environmental limits.

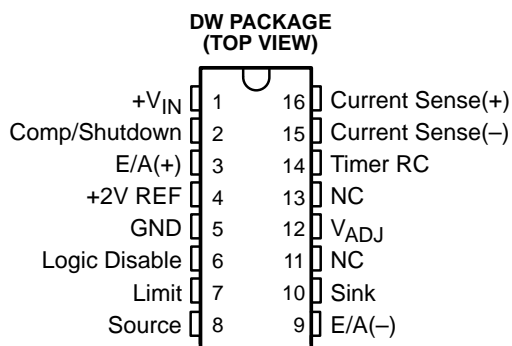

NC = No Connect

description

The UC2832 series of precision linear regulators include all the control functions required in the design of very low dropout linear regulators. Additionally, they feature an innovative duty-ratio current limiting technique which provides peak load capability while limiting the average power dissipation of the external pass transistor during fault conditions. When the load current reaches an accurately programmed threshold, a gated-astable timer is enabled, which switches the regulator's pass device off and on at an externally programmable duty-ratio. During the on-time of the pass element, the output current is limited to a value slightly higher than the trip threshold of the duty-ratio timer. The constant-current-limit is programmable on the UC2832 to allow higher peak current during the on-time of the pass device. With duty-ratio control, high initial load demands and short circuit protection may both be accommodated without extra heat sinking or foldback current limiting. Additionally, if the timer pin is grounded, the duty-ratio timer is disabled, and the IC operates in constant-voltage/constant-current regulating mode.

These IC's include a 2 Volt ($\pm 1\%$) reference, error amplifier, UVLO, and a high current driver that has both source and sink outputs, allowing the use of either NPN or PNP external pass transistors. Safe operation is assured by the inclusion of under-voltage lockout (UVLO) and thermal shutdown.

ORDERING INFORMATION‡

T _A	PACKAGE§		ORDERABLE PART NUMBER	TOP-SIDE MARKING
–40°C to 105°C	SOP – DW	Tape and reel	UC2832TDWREP	UC2832TEP
–40°C to 105°C	SOP – DW	Tube	UC2832TDWEP	UC2832TEP

‡ Package drawings, standard packing quantities, thermal data, symbolization, and PCB design guidelines are available at www.ti.com/sc/package.



Please be aware that an important notice concerning availability, standard warranty, and use in critical applications of Texas Instruments semiconductor products and disclaimers thereto appears at the end of this data sheet.

PRODUCTION DATA information is current as of publication date. Products conform to specifications per the terms of Texas Instruments standard warranty. Production processing does not necessarily include testing of all parameters.

 **TEXAS
INSTRUMENTS**

POST OFFICE BOX 655303 • DALLAS, TEXAS 75265

Copyright © 2003, Texas Instruments Incorporated

UC2832-EP PRECISION LOW DROPOUT LINEAR CONTROLLER

SGLS147A – JANUARY 2003 – REVISED MARCH 2003

block diagram

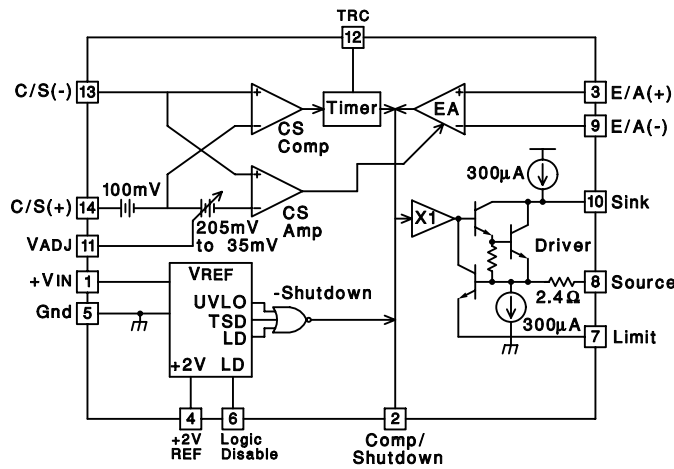

Ordering Information

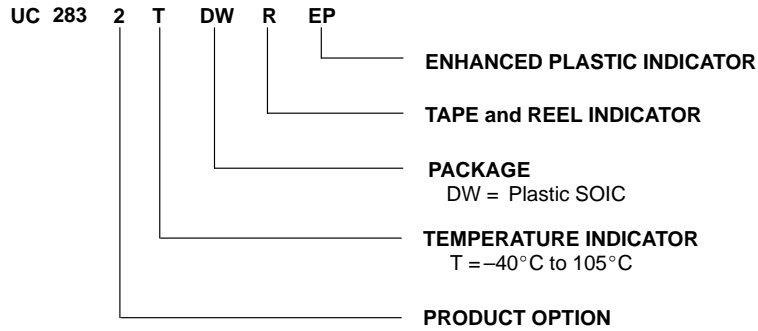

UC2832-EP PRECISION LOW DROPOUT LINEAR CONTROLLER

SGLS147A – JANUARY 2003 – REVISED MARCH 2003

absolute maximum ratings over operating free-air temperature range (unless otherwise noted)†‡

V_{IN} supply voltage	40 V
Driver output current (sink or source), I_O	450 mA
Driver sink to source voltage	40 V
TRC pin voltage	-0.3 V to 3.2 V
Other input voltages	-0.3 V to supply voltage
Operating junction temperature range, T_J	-55°C to 150°C
Storage temperature range, T_{stg}	-65°C to 150°C
Lead temperature soldering 1,6 mm (1/16 inch) from case for 10 seconds	300°C

† Stresses beyond those listed under “absolute maximum ratings” may cause permanent damage to the device. These are stress ratings only, and functional operation of the device at these or any other conditions beyond those indicated under “recommended operating conditions” is not implied. Exposure to absolute-maximum-rated conditions for extended periods may affect device reliability.

‡ Unless otherwise indicated, voltages are reference to ground and currents are positive into and negative out of the specified terminals.

electrical characteristics, $T_A = -40^\circ\text{C}$ to 105°C for the UC2832T-EP, $+V_{IN} = 15\text{ V}$, Driver sink = $+V_{IN}$, C/S(+) voltage = $+V_{IN}$, and $T_A = T_J$ (unless otherwise stated)

PARAMETER	TEST CONDITIONS	MIN	TYP	MAX	UNITS	
Input Supply						
Supply current	$+V_{IN} = 6\text{ V}$		6.5	10	mA	
	$+V_{IN} = 36\text{ V}$		9.5	15		
	Logic Disable = 2 V		3.3	10		
Reference Section						
Output voltage	$I_{DRIVER} = 10\text{ mA}$	$T_J = 25^\circ\text{C}$	1.98	2	2.02	V
		$T_J = \text{Full range}$	1.96	2	2.04	
Load regulation voltage	$I_{OUT} = 0$ to 10 mA	-10	-5	10	mV	
Line regulation	$+V_{IN} = 4.5\text{ V}$ to 36 V, $I_{DRIVER} = 10\text{ mA}$		0.033	0.5	mV/V	
Under-voltage lockout threshold			3.6	4.5	V	
Logic Disable Input						
Threshold voltage		1.3	1.4	1.5	V	
Input bias current	Logic Disable = 0 V	-5	-1	0.1	μA	
Current Sense Section						
Comparator offset	$T_J = 25^\circ\text{C}$	95	100	105	mV	
	$T_J = \text{Full range}$	93	100	107		
Amplifier offset	$V_{ADJ} = \text{Open}$	110	135	170	mV	
	$V_{ADJ} = 1\text{ V}$	180	235	290		
	$V_{ADJ} = 0\text{ V}$	250	305	360		
Input bias current	$V_{CM} = +V_{IN}$	65	100	135	μA	
Input offset current	$V_{CM} = +V_{IN}$	-10		10	μA	
Amplifier CMRR	$V_{CM} = 4.1\text{ V}$ to $+V_{IN} + 0.3\text{ V}$		80		dB	
Transconductance	$I_{COMP} = \pm 100\ \mu\text{A}$		65		ms	
V_{ADJ} input current	$V_{ADJ} = 0\text{ V}$	-10	-1		μA	

UC2832-EP PRECISION LOW DROPOUT LINEAR CONTROLLER

SGLS147A – JANUARY 2003 – REVISED MARCH 2003

electrical characteristics, $T_A = -40^\circ\text{C}$ to 105°C for the UC2832T-EP, $+V_{IN} = 15\text{ V}$, Driver sink = $+V_{IN}$, C/S(+) voltage = $+V_{IN}$, and $T_A = T_J$ (unless otherwise stated)

PARAMETER	TEST CONDITIONS	MIN	TYP	MAX	UNITS	
Timer						
Inactive leakage current	C/S(+) = C/S(-) = $+V_{IN}$, TRC pin = 2 V		0.25	1	μA	
Active pull-up current	C/S(+) = $+V_{IN}$, TRC pin = 0 V, C/S(-) = $+V_{IN} - 0.4\text{ V}$	-345	-270	-175	μA	
Duty ratio (See Note 1)	ontime/period, $R_T = 200\text{ k}\Omega$, $C_T = 0.27\text{ }\mu\text{F}$		4.8		%	
Period (See Notes 1 and 2)	ontime + offtime, $R_T = 200\text{ k}\Omega$, $C_T = 0.27\text{ }\mu\text{F}$		36		ms	
Upper trip threshold (V_U)			1.8		V	
Lower trip threshold (V_L)			0.9		V	
Trip threshold ratio	V_U / V_L		2.0		V/V	
Error Amplifier Section						
Input offset voltage	$V_{CM} = V_{COMP} = 2\text{ V}$	-8		8	mV	
Input bias current	$V_{CM} = V_{COMP} = 2\text{ V}$	-4.5	-1.1		μA	
Input offset current	$V_{CM} = V_{COMP} = 2\text{ V}$	-1.5		1.5	μA	
Open loop voltage gain (A_{VOL})	$V_{COMP} = 1\text{ V}$ to 13 V	50	70		dB	
Common mode rejection ratio (CMRR)	$V_{CM} = 0\text{ V}$ to $+V_{IN} - 3\text{ V}$	60	80		dB	
PSRR	$V_{CM} = 2\text{ V}$, $+V_{IN} = 4.5\text{ V}$ to 36 V		90		dB	
Transconductance	$I_{COMP} = \pm 10\text{ }\mu\text{A}$		4.3		ms	
High-level output voltage (V_{OH})	$I_{COMP} = 0$, Volts below $+V_{IN}$		0.95	1.3	V	
Low-level output voltage (V_{OL})	$I_{COMP} = 0$		4.5	0.7	V	
Output high current (I_{OH})	$V_{COMP} = 2\text{ V}$	-700	-500	-100	μA	
Output low current (I_{OL})	$V_{COMP} = 2\text{ V}$	C/S(-) = $+V_{IN}$	100	500	700	μA
		C/S(-) = $+V_{IN} - 0.4\text{ V}$	2	6		mA

- NOTES: 1. These parameters are first-order supply-independent, however, both may vary with supply for $+V_{IN}$ less than about 4 V. This supply variation will cause a slight change in the timer period and duty cycle, although a high off-time/on-time ratio will be maintained.
2. With recommended R_T value of 200 k Ω , $T_{OFF} \approx R_T C_T \cdot \ln(V_U/V_L) \pm 10\%$.

UC2832-EP
PRECISION LOW DROPOUT LINEAR CONTROLLER

SGLS147A – JANUARY 2003 – REVISED MARCH 2003

electrical characteristics, $T_A = -40^\circ\text{C}$ to 105°C for the UC2832T-EP, $+V_{IN} = 15\text{ V}$, Driver sink = $+V_{IN}$, C/S(+) voltage = $+V_{IN}$, and $T_A = T_J$ (unless otherwise stated)

PARAMETER	TEST CONDITIONS	MIN	TYP	MAX	UNITS	
Driver Section						
Maximum current	Driver limit and source pins common	$T_J = 25^\circ\text{C}$	200	300	400	mA
		$T_J = \text{Full range}$	100	300	450	
Limiting voltage	Driver limit to source voltage at current limit, $I_{\text{SOURCE}} = -10\text{ mA}$, $T_J = 25^\circ\text{C}$, See Note 3		0.72		V	
Internal current sense resistance	$T_J = 25^\circ\text{C}$, See Note 3		2.4		Ω	
Pull-up current at driver sink	Compensation/Shutdown = 0.4 V	Driver sink = $+V_{IN} - 1\text{ V}$	-800	-300	-100	μA
		$+V_{IN} = 36\text{ V}$, Driver sink = 35 V	-1000	-300	-75	
Pull-down current at driver source	Compensation/Shutdown = 0.4 V, Driver source = 1 V	150	300	700	μA	
Saturation voltage sink to source	Driver source = 0 V, Driver current = 100 mA		1.5		V	
Maximum source voltage	Driver sink = $+V_{IN}$, Driver current = 100 mA, Volts below $+V_{IN}$		3		V	
UVLO sink leakage	$+V_{IN} = \text{C/S}(+) = \text{C/S}(-) = 2.5\text{ V}$, Driver sink = 15 V, Driver source = 0 V, $T_A = 25^\circ\text{C}$		25		μA	
Maximum reverse source voltage	Compensation/Shutdown = 0 V, $I_{\text{SOURCE}} = 100\ \mu\text{A}$, $(+)V_{IN} = 3\text{ V}$		1.6		V	
Thermal shutdown			160		$^\circ\text{C}$	

NOTES: 3. The internal current limiting voltage has a temperature dependence of approximately $-2.0\text{ mV}/^\circ\text{C}$, or $-2800\text{ ppm}/^\circ\text{C}$. The internal $2.4\ \Omega$ sense resistor has a temperature dependence of approximately $+1500\text{ ppm}/^\circ\text{C}$.

APPLICATION AND OPERATION INFORMATION

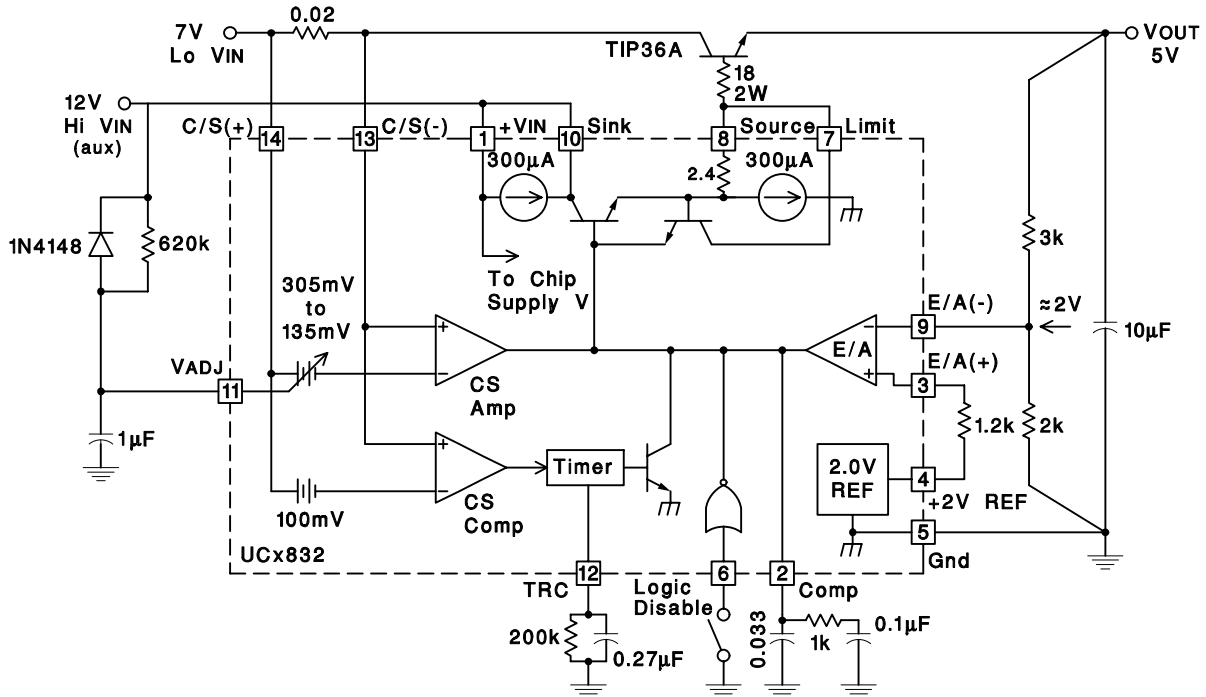

Figure 1. NPN Pass (Medium Power, Low Drop-Out Regulator)

UC2832-EP
PRECISION LOW DROPOUT LINEAR CONTROLLER

SGLS147A – JANUARY 2003 – REVISED MARCH 2003

APPLICATION AND OPERATION INFORMATION

Estimating Maximum Load Capacitance

For any power supply, the rate at which the total output capacitance can be charged depends on the maximum output current available and on the nature of the load. For a constant-current current-limited power supply, the output will come up if the load asks for less than the maximum available short-circuit limit current.

To ensure recovery of a duty-ratio current-limited power supply from a short-circuited load condition, there is a maximum total output capacitance which can be charged for a given unit ON time. The design value of ON time can be adjusted by changing the timing capacitor. Nominally, $T_{ON} = 0.693 \times 10 \text{ k}\Omega \times C_T$.

Typically, the IC regulates output current to a maximum of $I_{MAX} = K \times I_{TH}$, where I_{TH} is the timer trip-point current, and

$$K = \frac{\text{Current Sense Amplifier Offset Voltage}}{100 \text{ mA}}$$

and is variable from 1.35 to 3.05 with V_{ADJ} .

For a worst-case constant-current load of value just less than I_{TH} , C_{MAX} can be estimated from:

$$C_{MAX} = \left(\frac{K - 1}{I_{TH}} \right) \times \left(\frac{T_{ON}}{V_{OUT}} \right)$$

where V_{OUT} is the nominal regulator output voltage.

For a resistive load of value R_L , the value of C_{MAX} can be estimated from:

$$C_{MAX} = \frac{T_{ON}}{R_L} \times \frac{1}{\ln \left[\left(1 - \frac{V_{OUT}}{K \times I_{TH} \times R_L} \right)^{-1} \right]}$$

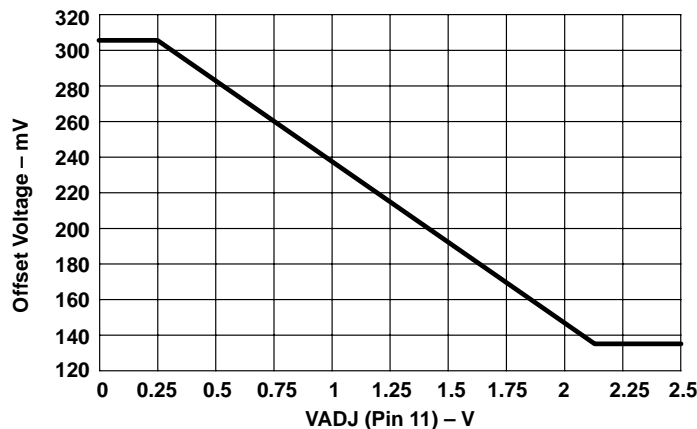

Figure 2. Current Sense Amplifier Offset Voltage vs V_{ADJ}

APPLICATION AND OPERATION INFORMATION

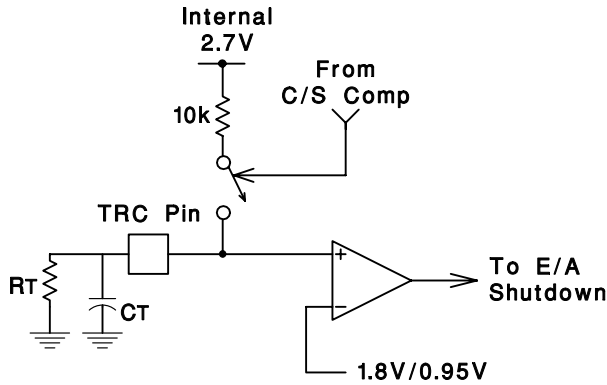
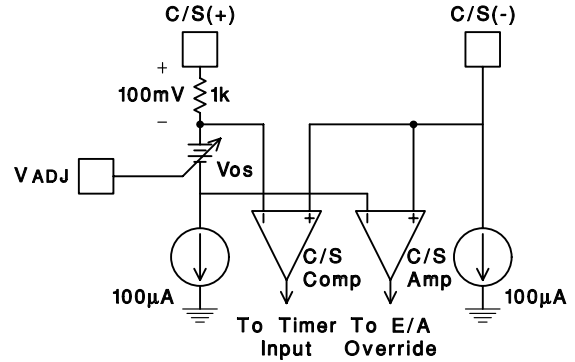

Figure 3. Timer Function



NOTE A: $V_{OS} = 205 \text{ mV to } 35 \text{ mV}$

Figure 4. Current Sense Input Configuration

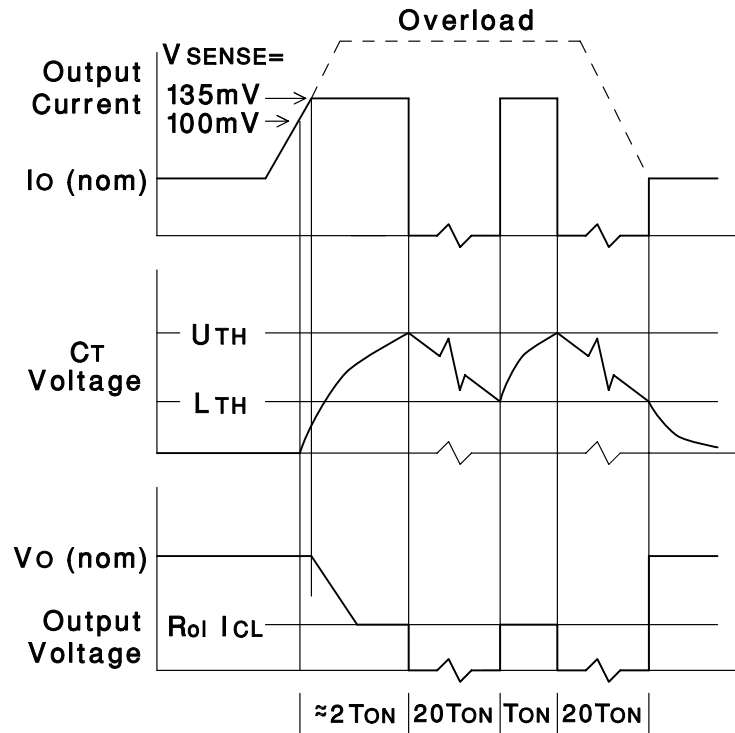

Figure 5. Load Current, Timing Capacitor Voltage, and Output Voltage of the Regulator Under Fault Conditions

UC2832-EP
PRECISION LOW DROPOUT LINEAR CONTROLLER

SGLS147A – JANUARY 2003 – REVISED MARCH 2003

APPLICATION AND OPERATION INFORMATION

UCx832 Error Amplifier

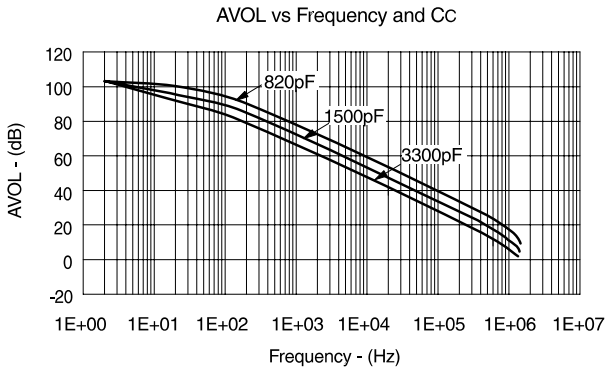

Figure 6. UCx832 Error Amplifier

UCx832 Current Sense Amplifier

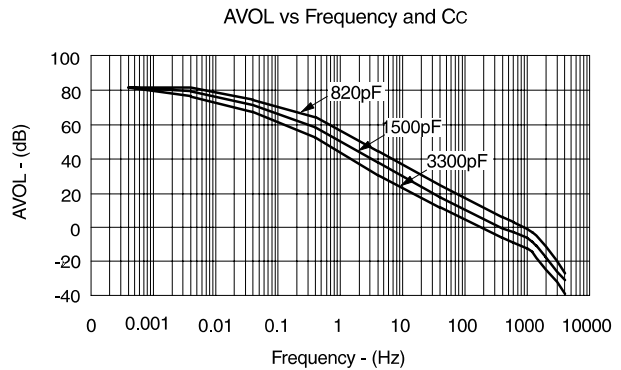

Figure 7. UCx832 Current Sense Amplifier

UCx832 Error Amplifier

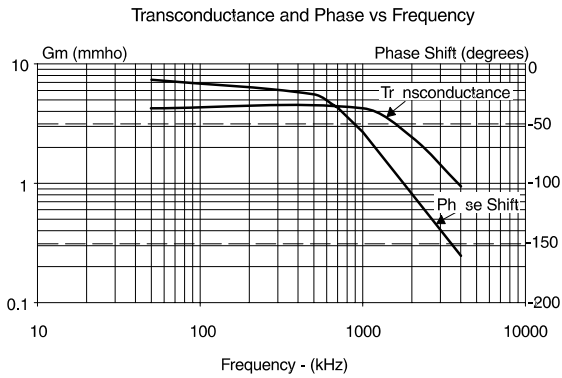

Figure 8. UCx832 Error Amplifier

UCx832 Current Sense Amplifier

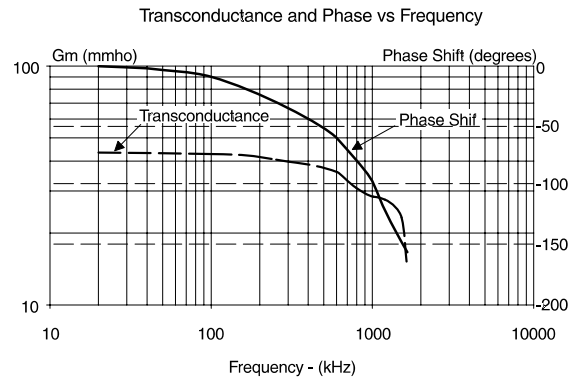

Figure 9. UCx832 Current Sense Amplifier



PACKAGING INFORMATION

Orderable Device	Status (1)	Package Type	Package Drawing	Pins	Package Qty	Eco Plan (2)	Lead/Ball Finish (6)	MSL Peak Temp (3)	Op Temp (°C)	Device Marking (4/5)	Samples
UC2832TDWEP	ACTIVE	SOIC	DW	16	40	Green (RoHS & no Sb/Br)	CU NIPDAU	Level-2-260C-1 YEAR	-40 to 105	UC2832TEP	

(1) The marketing status values are defined as follows:

ACTIVE: Product device recommended for new designs.

LIFEBUY: TI has announced that the device will be discontinued, and a lifetime-buy period is in effect.

NRND: Not recommended for new designs. Device is in production to support existing customers, but TI does not recommend using this part in a new design.

PREVIEW: Device has been announced but is not in production. Samples may or may not be available.

OBSELETE: TI has discontinued the production of the device.

(2) Eco Plan - The planned eco-friendly classification: Pb-Free (RoHS), Pb-Free (RoHS Exempt), or Green (RoHS & no Sb/Br) - please check <http://www.ti.com/productcontent> for the latest availability information and additional product content details.

TBD: The Pb-Free/Green conversion plan has not been defined.

Pb-Free (RoHS): TI's terms "Lead-Free" or "Pb-Free" mean semiconductor products that are compatible with the current RoHS requirements for all 6 substances, including the requirement that lead not exceed 0.1% by weight in homogeneous materials. Where designed to be soldered at high temperatures, TI Pb-Free products are suitable for use in specified lead-free processes.

Pb-Free (RoHS Exempt): This component has a RoHS exemption for either 1) lead-based flip-chip solder bumps used between the die and package, or 2) lead-based die adhesive used between the die and leadframe. The component is otherwise considered Pb-Free (RoHS compatible) as defined above.

Green (RoHS & no Sb/Br): TI defines "Green" to mean Pb-Free (RoHS compatible), and free of Bromine (Br) and Antimony (Sb) based flame retardants (Br or Sb do not exceed 0.1% by weight in homogeneous material)

(3) MSL, Peak Temp. - The Moisture Sensitivity Level rating according to the JEDEC industry standard classifications, and peak solder temperature.

(4) There may be additional marking, which relates to the logo, the lot trace code information, or the environmental category on the device.

(5) Multiple Device Markings will be inside parentheses. Only one Device Marking contained in parentheses and separated by a "-" will appear on a device. If a line is indented then it is a continuation of the previous line and the two combined represent the entire Device Marking for that device.

(6) Lead/Ball Finish - Orderable Devices may have multiple material finish options. Finish options are separated by a vertical ruled line. Lead/Ball Finish values may wrap to two lines if the finish value exceeds the maximum column width.

Important Information and Disclaimer: The information provided on this page represents TI's knowledge and belief as of the date that it is provided. TI bases its knowledge and belief on information provided by third parties, and makes no representation or warranty as to the accuracy of such information. Efforts are underway to better integrate information from third parties. TI has taken and continues to take reasonable steps to provide representative and accurate information but may not have conducted destructive testing or chemical analysis on incoming materials and chemicals. TI and TI suppliers consider certain information to be proprietary, and thus CAS numbers and other limited information may not be available for release.

In no event shall TI's liability arising out of such information exceed the total purchase price of the TI part(s) at issue in this document sold by TI to Customer on an annual basis.



Distributor of Texas Instruments: Excellent Integrated System Limited

Datasheet of UC2832TDWEP - IC REG CTRLR SGL 2V 16-SOIC

Contact us: sales@integrated-circuit.com Website: www.integrated-circuit.com

PACKAGE OPTION ADDENDUM

www.ti.com

17-Dec-2015

OTHER QUALIFIED VERSIONS OF UC2832-EP :

- Catalog: [UC2832](#)

NOTE: Qualified Version Definitions:

- Catalog - TI's standard catalog product

IMPORTANT NOTICE

Texas Instruments Incorporated and its subsidiaries (TI) reserve the right to make corrections, enhancements, improvements and other changes to its semiconductor products and services per JESD46, latest issue, and to discontinue any product or service per JESD48, latest issue. Buyers should obtain the latest relevant information before placing orders and should verify that such information is current and complete. All semiconductor products (also referred to herein as “components”) are sold subject to TI’s terms and conditions of sale supplied at the time of order acknowledgment.

TI warrants performance of its components to the specifications applicable at the time of sale, in accordance with the warranty in TI’s terms and conditions of sale of semiconductor products. Testing and other quality control techniques are used to the extent TI deems necessary to support this warranty. Except where mandated by applicable law, testing of all parameters of each component is not necessarily performed.

TI assumes no liability for applications assistance or the design of Buyers’ products. Buyers are responsible for their products and applications using TI components. To minimize the risks associated with Buyers’ products and applications, Buyers should provide adequate design and operating safeguards.

TI does not warrant or represent that any license, either express or implied, is granted under any patent right, copyright, mask work right, or other intellectual property right relating to any combination, machine, or process in which TI components or services are used. Information published by TI regarding third-party products or services does not constitute a license to use such products or services or a warranty or endorsement thereof. Use of such information may require a license from a third party under the patents or other intellectual property of the third party, or a license from TI under the patents or other intellectual property of TI.

Reproduction of significant portions of TI information in TI data books or data sheets is permissible only if reproduction is without alteration and is accompanied by all associated warranties, conditions, limitations, and notices. TI is not responsible or liable for such altered documentation. Information of third parties may be subject to additional restrictions.

Resale of TI components or services with statements different from or beyond the parameters stated by TI for that component or service voids all express and any implied warranties for the associated TI component or service and is an unfair and deceptive business practice. TI is not responsible or liable for any such statements.

Buyer acknowledges and agrees that it is solely responsible for compliance with all legal, regulatory and safety-related requirements concerning its products, and any use of TI components in its applications, notwithstanding any applications-related information or support that may be provided by TI. Buyer represents and agrees that it has all the necessary expertise to create and implement safeguards which anticipate dangerous consequences of failures, monitor failures and their consequences, lessen the likelihood of failures that might cause harm and take appropriate remedial actions. Buyer will fully indemnify TI and its representatives against any damages arising out of the use of any TI components in safety-critical applications.

In some cases, TI components may be promoted specifically to facilitate safety-related applications. With such components, TI’s goal is to help enable customers to design and create their own end-product solutions that meet applicable functional safety standards and requirements. Nonetheless, such components are subject to these terms.

No TI components are authorized for use in FDA Class III (or similar life-critical medical equipment) unless authorized officers of the parties have executed a special agreement specifically governing such use.

Only those TI components which TI has specifically designated as military grade or “enhanced plastic” are designed and intended for use in military/aerospace applications or environments. Buyer acknowledges and agrees that any military or aerospace use of TI components which have **not** been so designated is solely at the Buyer’s risk, and that Buyer is solely responsible for compliance with all legal and regulatory requirements in connection with such use.

TI has specifically designated certain components as meeting ISO/TS16949 requirements, mainly for automotive use. In any case of use of non-designated products, TI will not be responsible for any failure to meet ISO/TS16949.

Products

Audio	www.ti.com/audio
Amplifiers	amplifier.ti.com
Data Converters	dataconverter.ti.com
DLP® Products	www.dlp.com
DSP	dsp.ti.com
Clocks and Timers	www.ti.com/clocks
Interface	interface.ti.com
Logic	logic.ti.com
Power Mgmt	power.ti.com
Microcontrollers	microcontroller.ti.com
RFID	www.ti-rfid.com
OMAP Applications Processors	www.ti.com/omap
Wireless Connectivity	www.ti.com/wirelessconnectivity

Applications

Automotive and Transportation	www.ti.com/automotive
Communications and Telecom	www.ti.com/communications
Computers and Peripherals	www.ti.com/computers
Consumer Electronics	www.ti.com/consumer-apps
Energy and Lighting	www.ti.com/energy
Industrial	www.ti.com/industrial
Medical	www.ti.com/medical
Security	www.ti.com/security
Space, Avionics and Defense	www.ti.com/space-avionics-defense
Video and Imaging	www.ti.com/video

TI E2E Community

e2e.ti.com