

Excellent Integrated System Limited

Stocking Distributor

Click to view price, real time Inventory, Delivery & Lifecycle Information:

[TE Connectivity AMP Connectors](#)
[768963-1](#)

For any questions, you can email us directly:

sales@integrated-circuit.com



**AMP* Connector-Specific Kit 768963-1 for
 AMP-LATCH* 2mm Receptacle Connectors**

PROPER USE GUIDELINES

Cumulative Trauma Disorders can result from the prolonged use of manually powered hand tools. AMP hand tools are intended for occasional use and low volume applications. AMP offers a wide selection of powered application equipment for extended-use, production operations.

CONNECTOR-SPECIFIC KIT 768963-1

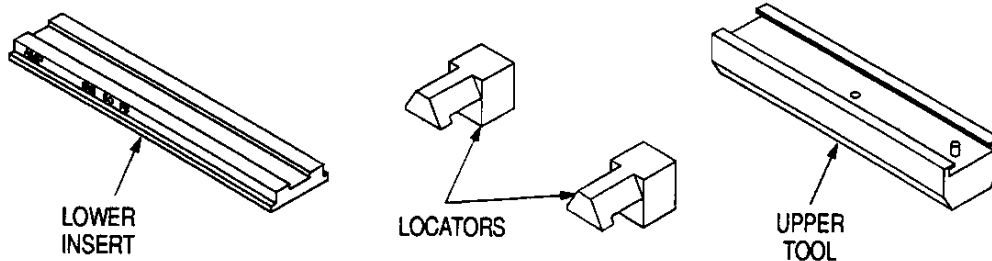

TYPICAL APPLICATION

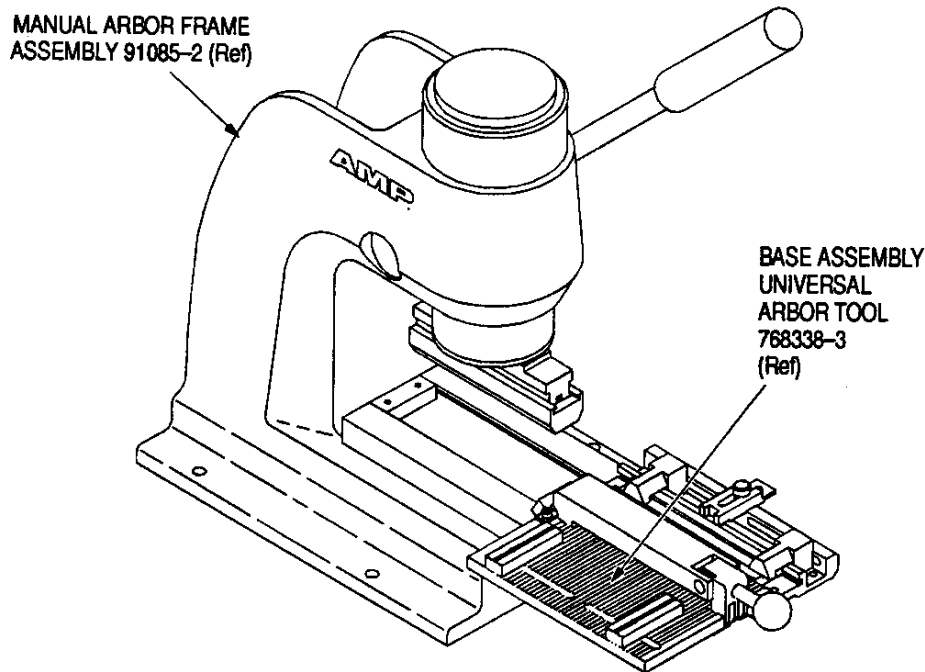

Figure 1

oad

1. INTRODUCTION

This instruction sheet covers the description, cable requirements, and installation procedures for AMP Connector-Specific Kit 768963-1, which is used with Base Assembly Universal Arbor Tool 768338-3 (see instruction sheet 408-9845). The connector-specific kit will terminate AMP-LATCH 2mm Receptacle Connectors to ribbon cable (see Figure 2).

The Base Assembly Universal Arbor Tool is used with AMP Manual Arbor Frame Assembly 91085-2 and AMP Pneumatic Auto-Cycle Unit 91112-3. Refer to 408-7777 and 408-6732, respectively, for tooling information.

NOTE

Dimensions on this sheet are in metric units [with U.S. customary units in brackets].

2. DESCRIPTION (Figure 1)

The connector-specific kit features an upper tool, two locators, and a lower insert. The upper tool applies an even force over the length of the connector during termination. The locators and the lower insert position the connector on the tooling assembly.

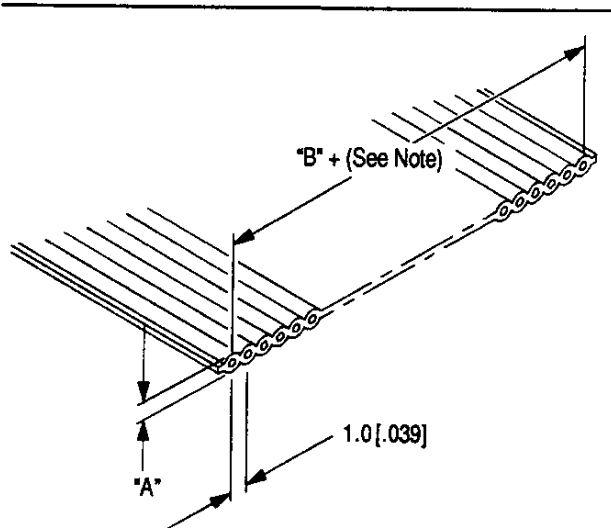

NOTE
 ACCUMULATIVE TOLERANCE FOR CABLE CONDUCTORS 1 THROUGH 34 IS + .25 [.010] AND THROUGH 60 IS + .38 [.015].

CONDUCTOR		DIMENSION	
SIZE (AWG)	TYPE	"A"	"B"
28	Stranded or Solid	.79 ± .18 mm [.031 ± .007 IN.]	1.0 mm [.039 IN.] X (Total No. of Conductors Minus One)

Figure 2 cad 9831

3. CABLE REQUIREMENTS

The connector-specific kit will terminate ribbon cable with 28 AWG solid or stranded conductors to all AMP-LATCH 2mm receptacle connectors. Refer to Figure 2 for the recommended cable dimensions.

CAUTION *The cable must be cut 90° to the edge of the cable; otherwise an improper termination will result. We suggest you use a guillotine-type cable cutter, such as the Carpenter Model 95 which can be purchased from:*

*Carpenter Manufacturing Co., Inc.
 Fairgrounds Drive
 Manlius, N.Y. 13207*

BASE ASSEMBLY UNIVERSAL
 ARBOR TOOL 768338-3
 (Ref)

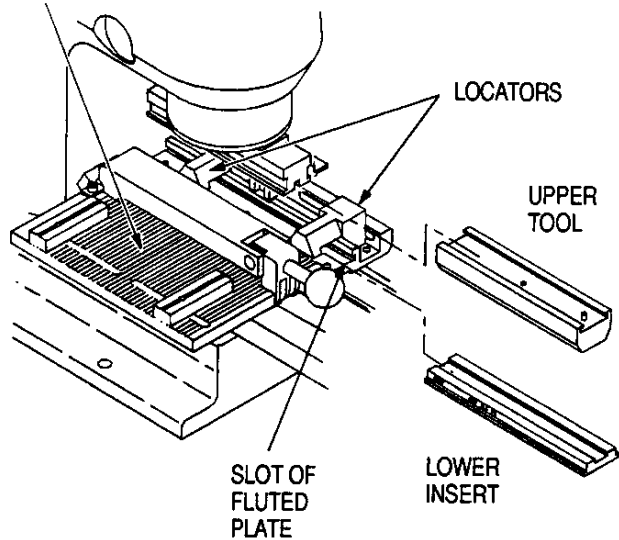

Figure 3 cad

4. CONNECTOR-SPECIFIC KIT INSTALLATION (Figure 3)

1. Slide the upper tool onto the upper tool mount.
2. Slide the lower insert into the slot of the fluted plate.
3. Secure the locators to the base tooling.

This completes the installation procedure.

NOTE *For information concerning termination procedures, refer to instruction sheet 408-9845 packaged with the Base Assembly Universal Arbor Tool.*

5. CONNECTOR-SPECIFIC KIT INSPECTION

Connector-Specific Kit 768963-1 has been inspected and should be verified with the information provided in Figure 4. It is recommended that the connector-specific kit be inspected immediately upon its arrival at your facility (and at regularly scheduled intervals) to ensure that the kit components have not been damaged during handling.

For additional information concerning connector-specific kits, or to purchase additional kits, contact your local AMP representative or:

CUSTOMER SERVICE (38-35)
 AMP INCORPORATED
 P.O. BOX 3608
 HARRISBURG, PA 17105-3608

CONNECTOR-SPECIFIC KIT 768963-1

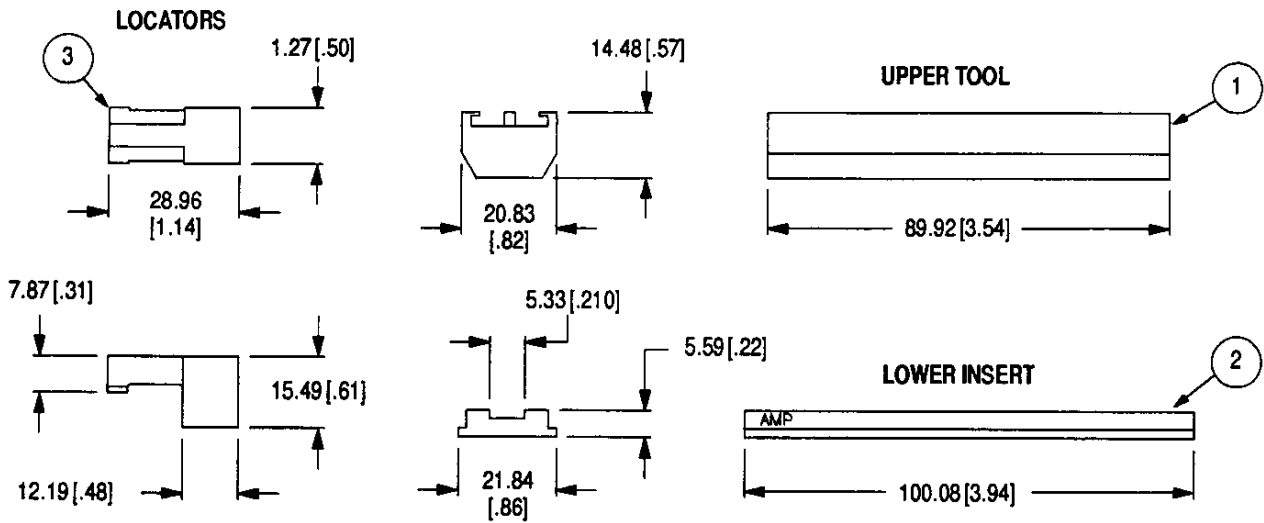

COMPONENT LIST

ITEM NO.	PART NUMBER	DESCRIPTION	QTY
1	354109-1	Upper Tool	1
2	768930-1	Lower Insert	1
3	768931-1	Locator	2

Figure 4

cad