

Excellent Integrated System Limited

Stocking Distributor

Click to view price, real time Inventory, Delivery & Lifecycle Information:

[International Rectifier \(Infineon Technologies Americas Corp.\)
IRF7805TRPBF](#)

For any questions, you can email us directly:

sales@integrated-circuit.com

IRF7805PbF

HEXFET® Chip-Set for DC-DC Converters

- N Channel Application Specific MOSFETs
- Ideal for Mobile DC-DC Converters
- Low Conduction Losses
- Low Switching Losses
- Lead-Free

Description

This new device employs advanced HEXFET Power MOSFET technology to achieve an unprecedented balance of on-resistance and gate charge. The reduced conduction and switching losses make this device ideal for high efficiency DC-DC Converters that power the latest generation of mobile microprocessors.

The IRF7805PbF offers maximum efficiency for mobile CPU core DC-DC converters.

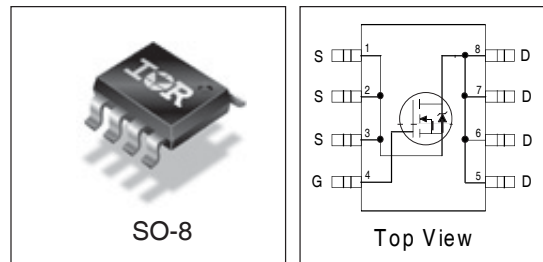

Device Features

| | IRF7805PbF |
|--------------|--------------|
| V_{DS} | 30V |
| $R_{DS(on)}$ | 11m Ω |
| Qg | 31nC |
| Qsw | 11.5nC |
| Qoss | 36nC |

Absolute Maximum Ratings

| | Parameter | Max. | Units |
|--------------------------------|---|--------------|---------------------|
| V_{DS} | Drain-to-Source Voltage | 30 | V |
| V_{GS} | Gate-to-Source Voltage | ± 12 | |
| $I_D @ T_A = 25^\circ\text{C}$ | Continuous Drain Current, $V_{GS} @ 10\text{V}$ ③ | 13 | A |
| $I_D @ T_A = 70^\circ\text{C}$ | Continuous Drain Current, $V_{GS} @ 10\text{V}$ ③ | 10 | |
| I_{DM} | Pulsed Drain Current ① | 100 | |
| $P_D @ T_A = 25^\circ\text{C}$ | Power Dissipation ③ | 2.5 | W |
| $P_D @ T_A = 70^\circ\text{C}$ | Power Dissipation ③ | 1.6 | |
| | Linear Derating Factor | 0.02 | W/ $^\circ\text{C}$ |
| T_J | Operating Junction and | -55 to + 150 | $^\circ\text{C}$ |
| T_{STG} | Storage Temperature Range | | |

Thermal Resistance

| | Parameter | Typ. | Max. | Units |
|-----------------|--------------------------|------|------|---------------------------|
| $R_{\theta JL}$ | Junction-to-Drain Lead ⑤ | — | 20 | $^\circ\text{C}/\text{W}$ |
| $R_{\theta JA}$ | Junction-to-Ambient ③⑤ | — | 50 | |

IRF7805PbF

 International

Static @ T_J = 25°C (unless otherwise specified)

| | Parameter | Min. | Typ. | Max. | Units | Conditions |
|---------------------|--|------|------|------|-------|---|
| BV _{DSS} | Drain-to-Source Breakdown Voltage [Ⓔ] | 30 | — | — | V | V _{GS} = 0V, I _D = 250μA |
| R _{DS(on)} | Static Drain-to-Source On-Resistance [Ⓔ] | — | 9.2 | 11 | mΩ | V _{GS} = 4.5V, I _D = 7.0A [Ⓔ] |
| V _{GS(th)} | Gate Threshold Voltage [Ⓔ] | 1.0 | — | 3.0 | V | V _{DS} = V _{GS} , I _D = 250μA |
| I _{DSS} | Drain-to-Source Leakage Current | — | — | 70 | μA | V _{DS} = 30V, V _{GS} = 0V |
| | | — | — | 10 | | V _{DS} = 24V, V _{GS} = 0V |
| | | — | — | 150 | | V _{DS} = 24V, V _{GS} = 0V, T _J = 100°C |
| I _{GSS} | Gate-to-Source Forward Leakage | — | — | 100 | nA | V _{GS} = 12V |
| | Gate-to-Source Reverse Leakage | — | — | -100 | | V _{GS} = -12V |
| Q _g | Total Gate Charge [Ⓔ] | — | 22 | 31 | nC | V _{GS} = 5.0V |
| Q _{gs1} | Pre-V _{th} Gate-to-Source Charge | — | 3.7 | — | | V _{DS} = 16V |
| Q _{gs2} | Post-V _{th} Gate-to-Source Charge | — | 1.4 | — | | I _D = 7.0A |
| Q _{gd} | Gate-to-Drain Charge | — | 6.8 | — | | |
| Q _{sw} | Switch Charge (Q _{gs2} + Q _{gd}) [Ⓔ] | — | 8.2 | 11.5 | | |
| Q _{oss} | Output Charge [Ⓔ] | — | 3.0 | 3.6 | nC | V _{DS} = 16V, V _{GS} = 0V |
| R _G | Gate Resistance | 0.5 | — | 1.7 | Ω | |
| t _{d(on)} | Turn-On Delay Time | — | 16 | — | ns | V _{DD} = 16V, V _{GS} = 4.5V [Ⓔ] |
| t _r | Rise Time | — | 20 | — | | I _D = 7.0A |
| t _{d(off)} | Turn-Off Delay Time | — | 38 | — | | R _G = 2Ω |
| t _f | Fall Time | — | 16 | — | | Resistive Load |

Diode Characteristics

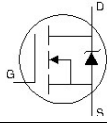
| | Parameter | Min. | Typ. | Max. | Units | Conditions |
|--------------------|--|------|------|------|-------|--|
| I _S | Continuous Source Current (Body Diode) [Ⓔ] | — | — | 2.5 | A | MOSFET symbol showing the integral reverse p-n junction diode. |
| I _{SM} | Pulsed Source Current (Body Diode) | — | — | 106 | |  |
| V _{SD} | Diode Forward Voltage [Ⓔ] | — | — | 1.2 | V | T _J = 25°C, I _S = 7.0A, V _{GS} = 0V |
| Q _{rr} | Reverse Recovery Charge [Ⓔ] | — | 88 | — | nC | di/dt = 700A/μs V _{DS} = 16V, V _{GS} = 0V, I _S = 7.0A |
| Q _{rr(s)} | Reverse Recovery Charge (with Parallel Schottky) [Ⓔ] | — | 55 | — | nC | di/dt = 700A/μs (with 10BQ040) V _{DS} = 16V, V _{GS} = 0V, I _S = 7.0A |

Notes:

- ① Repetitive rating; pulse width limited by max. junction temperature.
- ② Pulse width ≤ 300 μs; duty cycle ≤ 2%.
- ③ When mounted on 1 inch square copper board, t < 10 sec.
- ④ Typ = measured - Q_{oss}.
- ⑤ R_θ is measured at T_J of approximately 90°C.
- ⑥ Devices are 100% tested to these parameters.

International
IR Rectifier

Typical Characteristics

IRF7805PbF

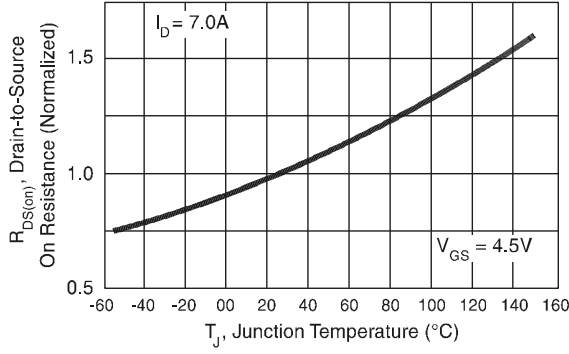

Fig 1. Normalized On-Resistance vs. Temperature

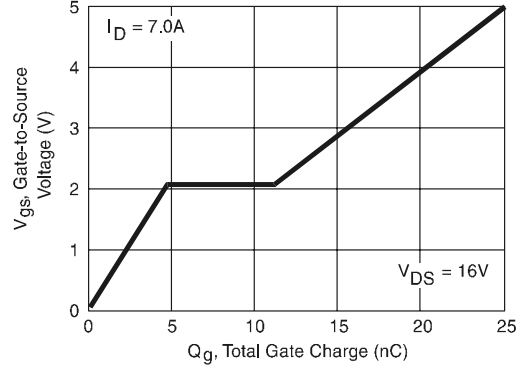

Fig 2. Typical Gate Charge vs. Gate-to-Source Voltage

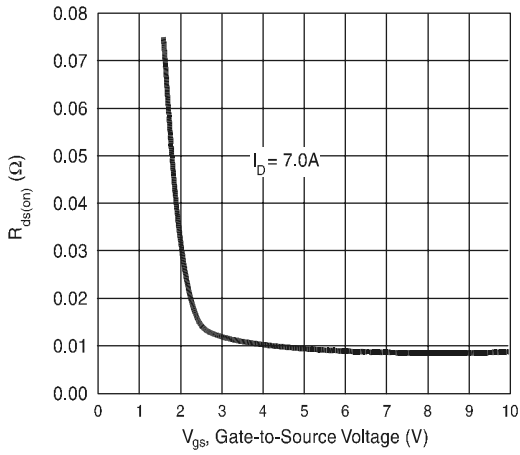

Fig 3. Typical $R_{DS(on)}$ vs. Gate-to-Source Voltage

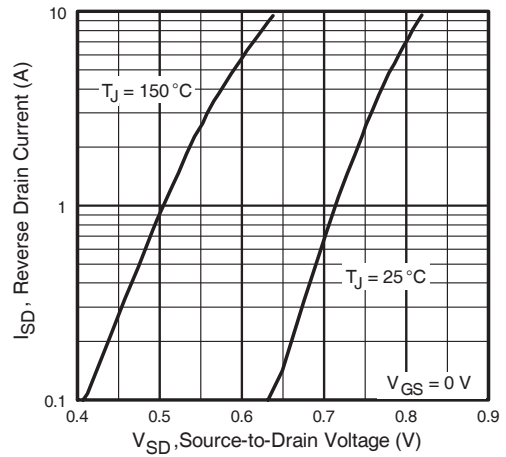

Fig 4. Typical Source-Drain Diode Forward Voltage

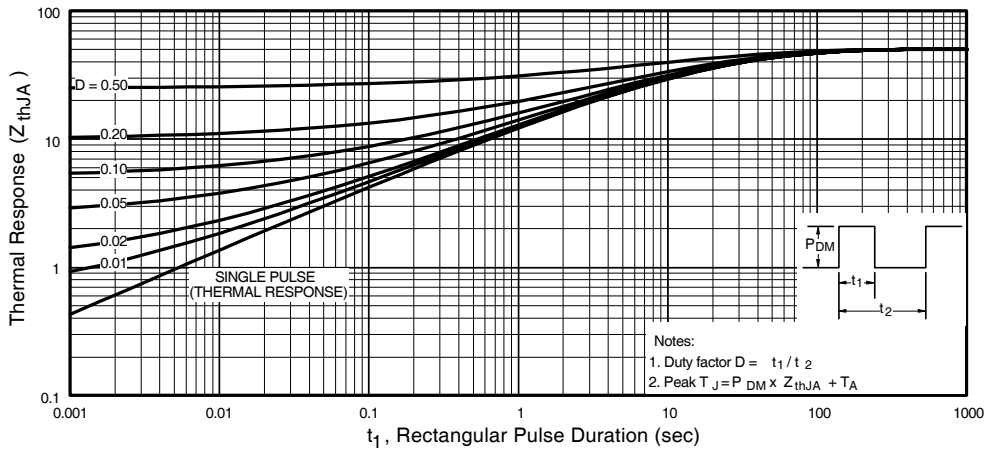
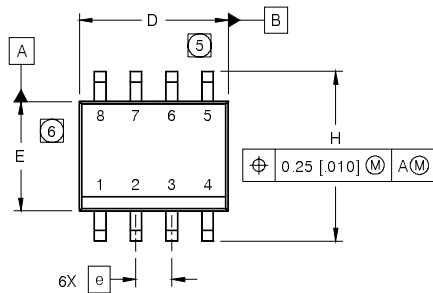

Figure 5. Maximum Effective Transient Thermal Impedance, Junction-to-Ambient

IRF7805PbF

SO-8 Package Details

International
IR Rectifier



| DIM | INCHES | | MILLIMETERS | |
|-----|------------|-------|-------------|------|
| | MIN | MAX | MIN | MAX |
| A | .0532 | .0688 | 1.35 | 1.75 |
| A1 | .0040 | .0098 | 0.10 | 0.25 |
| b | .013 | .020 | 0.33 | 0.51 |
| c | .0075 | .0098 | 0.19 | 0.25 |
| D | .189 | .1968 | 4.80 | 5.00 |
| E | .1497 | .1574 | 3.80 | 4.00 |
| e | .050 BASIC | | 1.27 BASIC | |
| e1 | .025 BASIC | | 0.635 BASIC | |
| H | .2284 | .2440 | 5.80 | 6.20 |
| K | .0099 | .0196 | 0.25 | 0.50 |
| L | .016 | .050 | 0.40 | 1.27 |
| y | 0° | 8° | 0° | 8° |

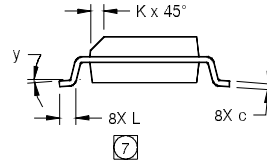
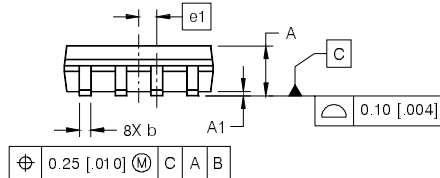

NOTES:

1. DIMENSIONING & TOLERANCING PER ASME Y14.5M-1994.
2. CONTROLLING DIMENSION: MILLIMETER
3. DIMENSIONS ARE SHOWN IN MILLIMETERS [INCHES].
4. OUTLINE CONFORMS TO JEDEC OUTLINE MS-012AA.
5. DIMENSION DOES NOT INCLUDE MOLD PROTRUSIONS. MOLD PROTRUSIONS NOT TO EXCEED 0.15 [0.006].
6. DIMENSION DOES NOT INCLUDE MOLD PROTRUSIONS. MOLD PROTRUSIONS NOT TO EXCEED 0.25 [0.010].
7. DIMENSION IS THE LENGTH OF LEAD FOR SOLDERING TO A SUBSTRATE.

FOOTPRINT

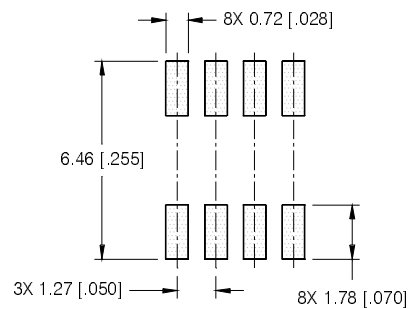

SO-8 Part Marking

EXAMPLE: THIS IS AN IRF7101 (MOSFET)

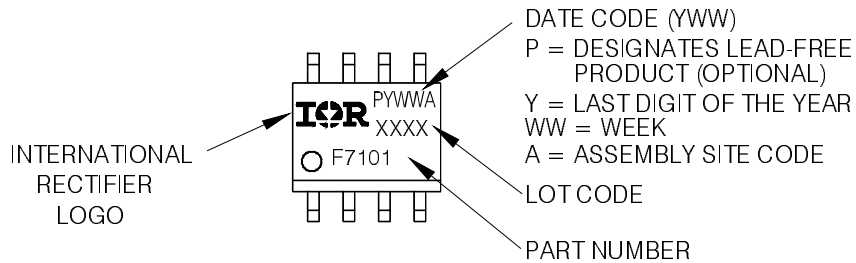

Note: For the most current drawing please refer to IR website at <http://www.irf.com/package/>

International
IOR Rectifier

IRF7805PbF

SO-8 Tape and Reel

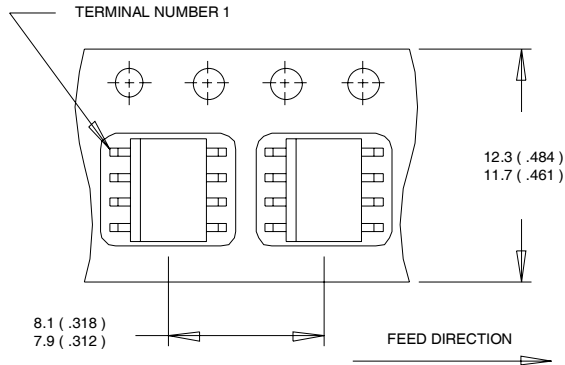

- NOTES:
1. CONTROLLING DIMENSION : MILLIMETER.
 2. ALL DIMENSIONS ARE SHOWN IN MILLIMETERS(INCHES).
 3. OUTLINE CONFORMS TO EIA-481 & EIA-541.

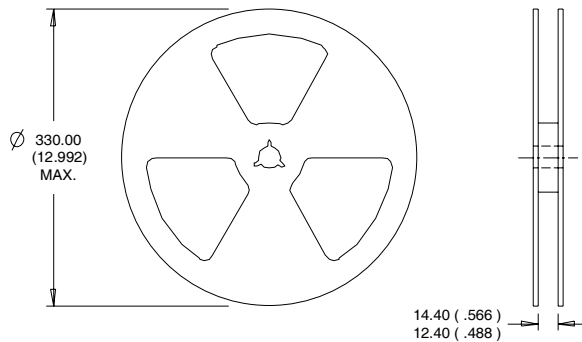

- NOTES :
1. CONTROLLING DIMENSION : MILLIMETER.
 2. OUTLINE CONFORMS TO EIA-481 & EIA-541.

Note: For the most current drawing please refer to IR website at <http://www.irf.com/package/>

International
IOR Rectifier

IR WORLD HEADQUARTERS: 233 Kansas St., El Segundo, California 90245, USA Tel: (310) 252-7105
 TAC Fax: (310) 252-7903

Visit us at www.irf.com for sales contact information.01/2008

www.irf.com