

## **Excellent Integrated System Limited**

Stocking Distributor

Click to view price, real time Inventory, Delivery & Lifecycle Information:

[Fairchild Semiconductor](#)  
[FSAV331QSCX](#)

For any questions, you can email us directly:  
[sales@integrated-circuit.com](mailto:sales@integrated-circuit.com)



April 2004  
 Revised August 2005

# FSAV331

## Dual Channel 4:1 Video Switch

### General Description

The Fairchild video switch FSAV331 is a dual 4:1 high speed video switch which can be configured as either multiplexer or demultiplexer. Low On Resistance allows inputs to be connected to outputs without adding propagation delay or generating additional ground bounce noise.

When the OE Pin is LOW, S<sub>0</sub> and S<sub>1</sub> connect the A Port to the selected B Port output. When the OE Pin is HIGH, the switch is OPEN and a HIGH-Impedance state exists between the two ports.

### Features

- Wide bandwidth: 300 MHz
- -73 dB non adjacent channel crosstalk at 10MHz
- -56 dB Off Isolation at 10MHz
- 3Ω typical On Resistance (R<sub>ON</sub>)
- Low power consumption (3uA maximum)
- Control input: TTL compatible

### Applications

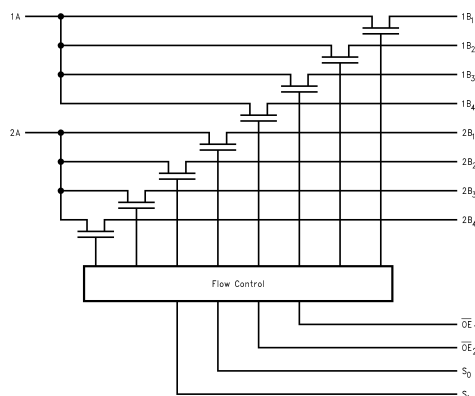
- Y/C video or CVBS video switch in LCD, plasma, and projector displays

### Ordering Code:

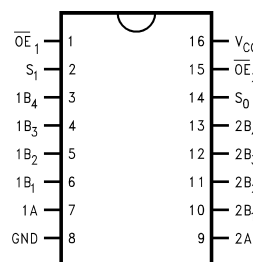
Order Number	Package Number	Package Description
FSAV331QSC	MQA16A	16-Lead Quarter Size Small Outline Package (QSOP), JEDEC MO-137, 0.150" Wide
FSAV331MTC	MTC16	16-Lead Thin Shrink Small Outline Package (TSSOP), JEDEC MO-153, 4.4mm Wide

Device also available in Tape and Reel. Specify by appending suffix letter "X" to the ordering code.

### Logic Diagram



### Connection Diagram



### Pin Descriptions

Pin Name	Description
OE <sub>1</sub> , OE <sub>2</sub>	Bus Switch Enables
S <sub>0</sub> , S <sub>1</sub>	Select Inputs
A	Bus A
B <sub>1</sub> , B <sub>2</sub> , B <sub>3</sub> , B <sub>4</sub>	Bus B

### Truth Table

S <sub>1</sub>	S <sub>0</sub>	OE <sub>1</sub>	OE <sub>2</sub>	Function
X	X	H	X	Disconnect 1A
X	X	X	H	Disconnect 2A
L	L	L	L	A = B <sub>1</sub>
L	H	L	L	A = B <sub>2</sub>
H	L	L	L	A = B <sub>3</sub>
H	H	L	L	A = B <sub>4</sub>

### Absolute Maximum Ratings (Note 1)

Supply Voltage ( $V_{CC}$ )	-0.5V to +7.0V
DC Switch Voltage (Note 2)	-0.5V to $V_{CC} + 0.5V$
DC Input Voltage ( $V_{IN}$ ) (Note 2)	-0.5V to +7.0V
DC Input Diode Current	-50 mA
DC Output Current	128 mA
Storage Temperature Range ( $T_{STG}$ )	-65°C to +150 °C
ESD (Human Body Model)	2000V

### Recommended Operating Conditions (Note 3)

Supply Voltage ( $V_{CC}$ )	4.75V to 5.25V
Control Input Voltage	0V to $V_{CC}$
Switch Input Voltage	0V to $V_{CC}$
Operating Temperature	-40°C to +85°C
Thermal Resistance	
(TSSOP)	100°C/W
(QSOP)	127°C/W

**Note 1:** The Absolute Maximum Ratings are those values beyond which the safety of the device cannot be guaranteed. The device should not be operated at these limits. The parametric values defined in the Electrical Characteristics tables are not guaranteed at the absolute maximum rating. The Recommended Operating Conditions tables will define the conditions for actual device operation.

**Note 2:** The input and output negative voltage ratings may be exceeded if the input and output diode current ratings are observed.

**Note 3:** Unused control inputs must be held HIGH or LOW. They may not float.

### DC Electrical Characteristics All typical value are for $V_{CC} = 5V @ 25^{\circ}C$ unless otherwise specified.

Symbol	Parameter	$V_{CC}$ (V)	$T_A = -40^{\circ}C$ to $+85^{\circ}C$			Units	Conditions
			Min	Typ	Max		
$V_{ANALOG}$	Analog Signal Range	4.75 - 5.25	0		2.0	V	
$V_{IK}$	Clamp Diode Voltage	4.75			-1.2	V	$I_{IN} = -18$ mA
$V_{IH}$	Input Voltage HIGH	4.75 - 5.25	2.0			V	
$V_{IL}$	Input Voltage LOW	4.75 - 5.25			0.8	V	
$I_{IN}$	Control Input Leakage	5.25			$\pm 1.0$	$\mu A$	$V_{IN} = 0V$ to $V_{CC}$
$I_{OZ}$	OFF-STATE Leakage Current	5.25			$\pm 1.0$	$\mu A$	$0 \leq A, B \leq V_{CC}$
$R_{ON}$	Switch On Resistance (Note 4)	4.75		3.3	7.0	$\Omega$	$V_{IN} = 1V, R_L = 75\Omega, I_{ON} = 13$ mA
		4.75		5.0	10.0	$\Omega$	$V_{IN} = 2V, R_L = 75\Omega, I_{ON} = 26$ mA
$I_{CC}$	Quiescent Supply Current	5.25			3.0	$\mu A$	$V_{IN} = 0V$ or $V_{CC}, I_{OUT} = 0V$

**Note 4:** Measured by the voltage drop between A and B Pins at the indicated current through the switch. On Resistance is determined by the lower of the voltages on the two (A or B Ports).

## AC Electrical Characteristics

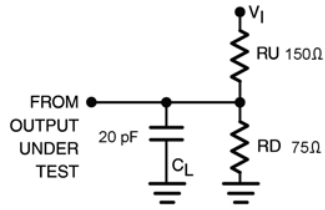
Symbol	Parameter	V <sub>CC</sub> (V)	T <sub>A</sub> = -40 °C to +85 °C			Units	Conditions	Figure Number
			Min	Typ	Max			
t <sub>ON</sub>	Turn ON Time S-to-Bus B	4.75 to 5.25	1.0		5.3	ns	V <sub>I</sub> = 7V for t <sub>pZL</sub> and V <sub>I</sub> = OPEN for t <sub>pZH</sub>	Figures 1, 2
	Output Enable Time OE-to-A or B	4.75 to 5.25	1.0		5.3			
t <sub>OFF</sub>	Turn OFF Time S-to-Bus B	4.75 to 5.25	1.0		5.8	ns	V <sub>I</sub> = 7V for t <sub>pLZ</sub> and V <sub>I</sub> = OPEN for t <sub>pHZ</sub>	Figures 1, 2
	Output Disable Time OE-to-A or B	4.75 to 5.25	1.0		5.5			
t <sub>PLH</sub>	Propagation Delay (Note 5)	4.75 to 5.25			0.1	ns	V <sub>I</sub> OPEN	Figures 1, 2
t <sub>PHL</sub>	Select-to-Bus A Delay	4.75 to 5.25			5.0			
DG	Differential Gain	4.75 to 5.25		0.26		%	R <sub>L</sub> = 150Ω, f = 3.58MHz	
DP	Differential Phase	4.75 to 5.25		0.23		Degree	R <sub>L</sub> = 150Ω, f = 3.58MHz	
O <sub>IRR</sub>	Non Adjacent OFF-Isolation	4.75 to 5.25		-56.0		dB	f = 10MHz, R <sub>L</sub> = 150Ω	Figure 3
X <sub>TALK</sub>	Non Adjacent Channel Crosstalk	4.75 to 5.25		-73.0		dB	R <sub>L</sub> = 150Ω, f = 10MHz	Figure 4
BW	-3dB Bandwidth	4.75 to 5.25		300		MHz	R <sub>L</sub> = 150Ω	Figure 5

**Note 5:** This specification is guaranteed by design.

## Capacitance

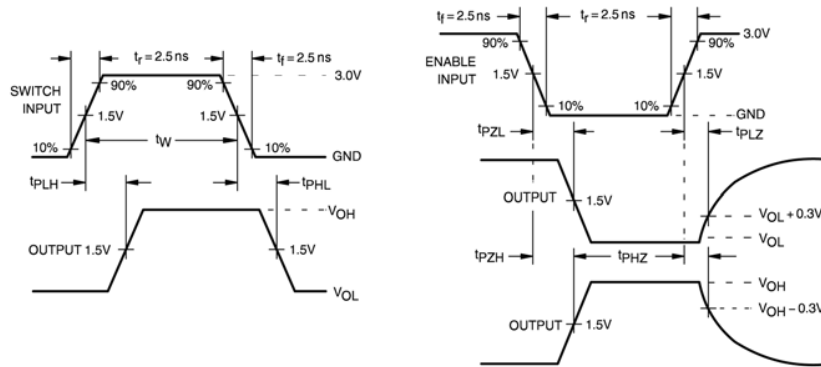
Symbol	Parameter	T <sub>A</sub> = -40 °C to +85 °C		Units	Conditions
		Typ			
C <sub>IN</sub>	Control Pin Input Capacitance	3.0		pF	V <sub>CC</sub> = 5.0V
C <sub>ON</sub>	A/B On Capacitance	39.0		pF	V <sub>CC</sub> = 5.0, $\overline{OE}$ = 0V
C <sub>OFF</sub>	Port B OFF Capacitance	5.0		pF	V <sub>CC</sub> and $\overline{OE}$ = 5.0V
	Port A OFF Capacitance	13.0		pF	

### AC Loading and Waveforms

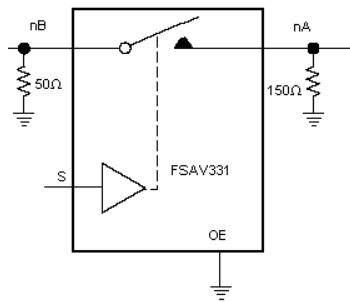


**Note:** Input driven by 50 Ω source terminated in 50 Ω  
**Note:**  $C_L$  includes load and stray capacitance  
**Note:** Input PRR = 1.0 MHz,  $t_W = 500$  ns

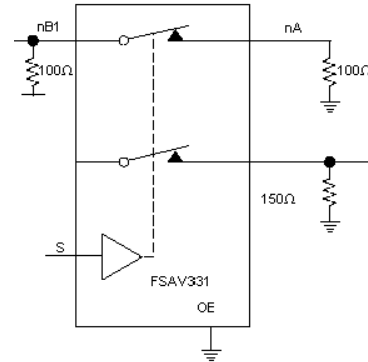
**FIGURE 1. AC Test Circuit**



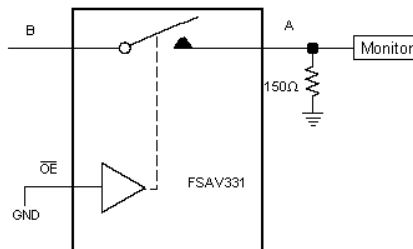
**FIGURE 2. AC Waveforms**



**FIGURE 3. OFF Isolation Test**

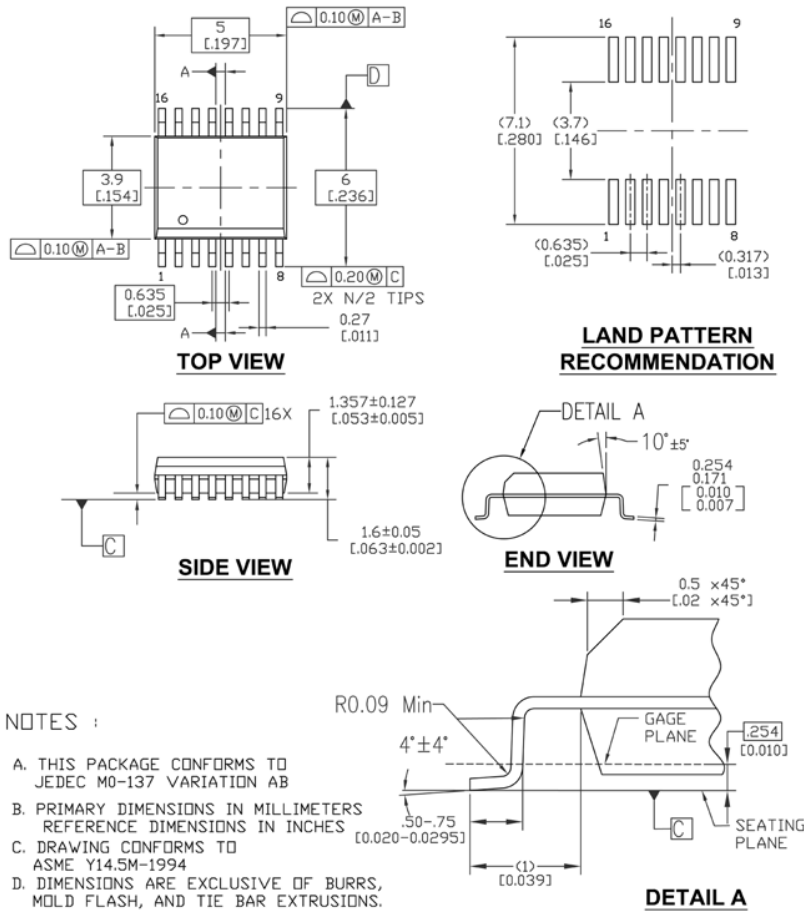


**FIGURE 4. Crosstalk Test**



**FIGURE 5. Bandwidth Test**

**Physical Dimensions** inches (millimeters) unless otherwise noted

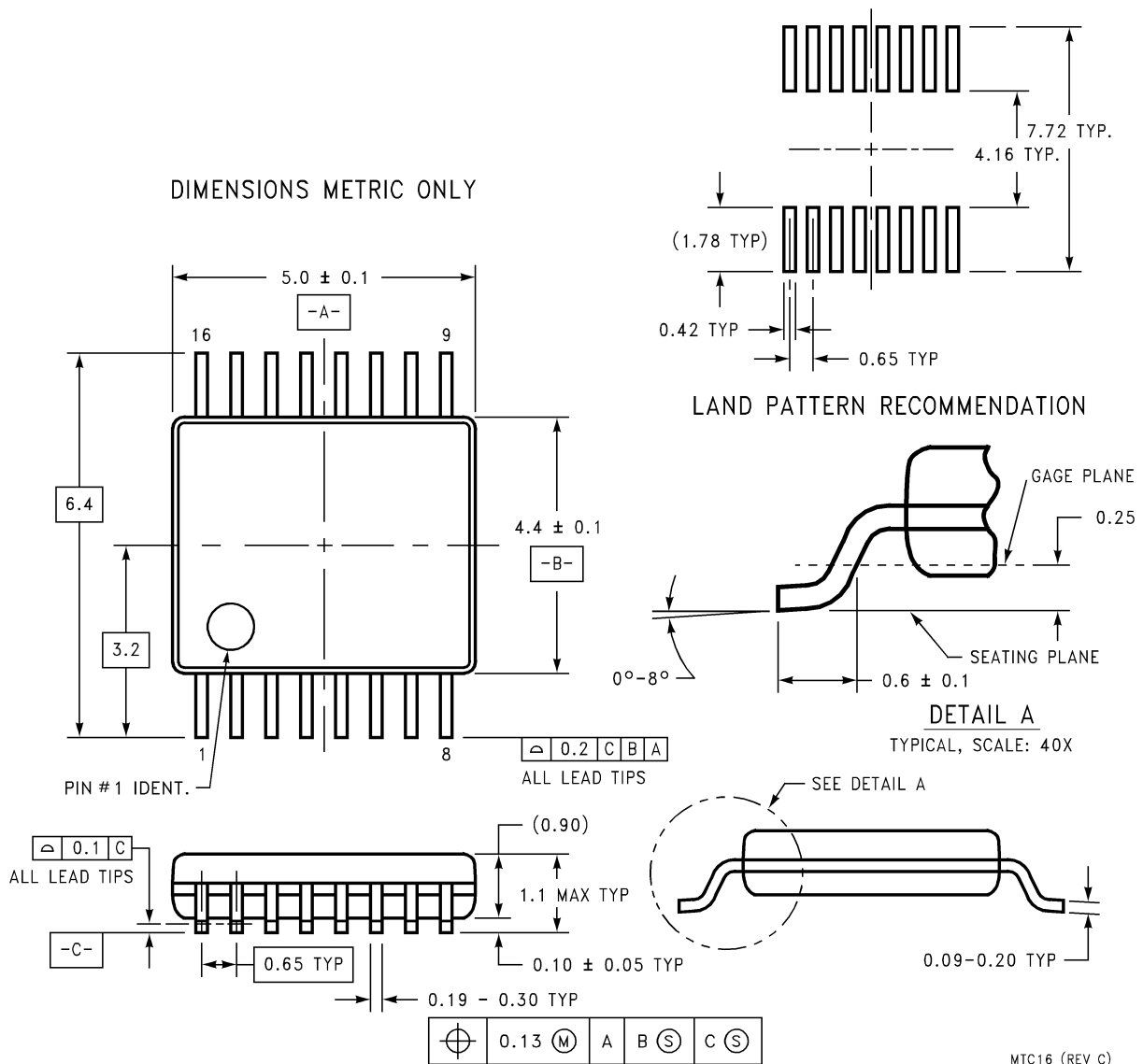


MQA16AREVB

**16-Lead Quarter Size Small Outline Package (QSOP), JEDEC MO-137, 0.150" Wide  
 Package Number MQA16A**

FSAV331

**Physical Dimensions** inches (millimeters) unless otherwise noted (Continued)



**16-Lead Thin Shrink Small Outline Package (TSSOP), JEDEC MO-153, 4.4mm Wide**  
**Package Number MTC16**

**Technology Description**

The Fairchild Switch family derives from and embodies Fairchild's proven switch technology used for several years in its 74LVX3L384 (FST3384) bus switch product.

---

## DISCLAIMER

FAIRCHILD SEMICONDUCTOR RESERVES THE RIGHT TO MAKE CHANGES WITHOUT FURTHER NOTICE TO ANY PRODUCTS HEREIN TO IMPROVE RELIABILITY, FUNCTION OR DESIGN. FAIRCHILD DOES NOT ASSUME ANY LIABILITY ARISING OUT OF THE APPLICATION OR USE OF ANY PRODUCT OR CIRCUIT DESCRIBED HEREIN; NEITHER DOES IT CONVEY ANY LICENSE UNDER ITS PATENT RIGHTS, NOR THE RIGHTS OF OTHERS.

---

## LIFE SUPPORT POLICY

FAIRCHILD'S PRODUCTS ARE NOT AUTHORIZED FOR USE AS CRITICAL COMPONENTS IN LIFE SUPPORT DEVICES OR SYSTEMS WITHOUT THE EXPRESS WRITTEN APPROVAL OF FAIRCHILD SEMICONDUCTOR CORPORATION

As used herein:

1. Life support devices or systems are devices or systems which, (a) are intended for surgical implant into the body, or (b) support or sustain life, or (c) whose failure to perform when properly used in accordance with instructions for use

provided in the labeling, can be reasonably expected to result in significant injury to the user.

2. A critical component is any component of a life support device or system whose failure to perform can be reasonably expected to cause the failure of the life support device or system, or to affect its safety or effectiveness.

---

## PRODUCT STATUS DEFINITIONS

Definition of terms

Datasheet Identification	Product Status	Definition
Advance Information	Formative or In Design	This datasheet contains the design specifications for product development. Specifications may change in any manner without notice.
Preliminary	First Production	This datasheet contains preliminary data, and supplementary data will be published at a later date. Fairchild Semiconductor reserves the right to make changes at any time without notice in order to improve design.
No Identification Needed	Full Production	This datasheet contains final specifications. Fairchild Semiconductor reserves the right to make changes at any time without notice in order to improve design.
Obsolete	Not In Production	This datasheet contains specifications on a product that has been discontinued by Fairchild Semiconductor. The datasheet is printed for reference information only.