

## Excellent Integrated System Limited

Stocking Distributor

Click to view price, real time Inventory, Delivery & Lifecycle Information:

[ON Semiconductor](#)  
[T2500DG](#)

For any questions, you can email us directly:

[sales@integrated-circuit.com](mailto:sales@integrated-circuit.com)

# T2500D

## Triacs

### Silicon Bidirectional Thyristors

Designed primarily for full-wave ac control applications, such as light dimmers, motor controls, heating controls and power supplies.

#### Features

- Blocking Voltage 400 V
- All Diffused and Glass Passivated Junctions for Greater Parameter Uniformity and Stability
- Small, Rugged, Thermowatt Construction for Low Thermal Resistance, High Heat Dissipation and Durability
- High Surge Current Capability 60 A Peak at  $T_C = 80^\circ\text{C}$
- Pb-Free Package is Available\*

#### MAXIMUM RATINGS ( $T_J = 25^\circ\text{C}$ unless otherwise noted)

Rating	Symbol	Value	Unit
Peak Repetitive Off-State Voltage (Note 1) (Sine Wave 50 to 60 Hz, $T_J = -40$ to $+100^\circ\text{C}$ , Gate Open)	$V_{DRM}$ , $V_{RRM}$	400	V
On-State RMS Current ( $T_C = +80^\circ\text{C}$ ) (Full Cycle Sine Wave 50 to 60 Hz)	$I_{T(RMS)}$	6.0	A
Peak Non-repetitive Surge Current (One Full Cycle, 60 Hz, $T_C = +80^\circ\text{C}$ )	$I_{TSM}$	60	A
Circuit Fusing Considerations ( $t = 8.3$ ms)	$I^2t$	15	$\text{A}^2\text{s}$
Peak Gate Power ( $T_C = +80^\circ\text{C}$ , Pulse Width = 10 $\mu\text{sec}$ )	$P_{GM}$	16	W
Average Gate Power ( $T_C = +80^\circ\text{C}$ , $t = 8.3$ ms)	$P_{G(AV)}$	0.2	W
Peak Gate Current (Pulse Width = 10 $\mu\text{sec}$ )	$I_{GM}$	4.0	A
Operating Junction Temperature Range	$T_J$	$-40$ to $+125$	$^\circ\text{C}$
Storage Temperature Range	$T_{stg}$	$-40$ to $+150$	$^\circ\text{C}$

#### THERMAL CHARACTERISTICS

Characteristic	Symbol	Max	Unit
Thermal Resistance, Junction-to-Case	$R_{\theta JC}$	2.7	$^\circ\text{C/W}$
Maximum Lead Temperature for Soldering Purposes 1/8" from Case for 10 Seconds	$T_L$	260	$^\circ\text{C}$

Stresses exceeding Maximum Ratings may damage the device. Maximum Ratings are stress ratings only. Functional operation above the Recommended Operating Conditions is not implied. Extended exposure to stresses above the Recommended Operating Conditions may affect device reliability.

1.  $V_{DRM}$ ,  $V_{RRM}$  for all types can be applied on a continuous basis. Blocking voltages shall not be tested with a constant current source such that the voltage ratings of the devices are exceeded.

\*For additional information on our Pb-Free strategy and soldering details, please download the ON Semiconductor Soldering and Mounting Techniques Reference Manual, SOLDERRM/D.



**ON Semiconductor®**

<http://onsemi.com>

**TRIACS**  
**6 AMPERES RMS**  
**400 VOLTS**

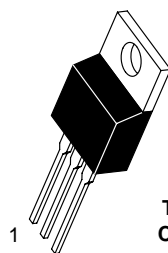
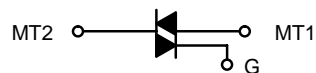

**TO-220AB**  
**CASE 221A**  
**STYLE 4**

#### MARKING DIAGRAM

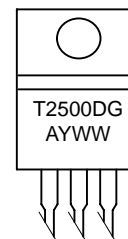

- A = Assembly Location
- Y = Year
- WW = Work Week
- G = Pb-Free Package

#### PIN ASSIGNMENT

Pin	Assignment
1	Main Terminal 1
2	Main Terminal 2
3	Gate
4	Main Terminal 2

#### ORDERING INFORMATION

Device	Package	Shipping
T2500D	TO220AB	500 Units / Box
T2500DG	TO220AB (Pb-Free)	500 Units / Box

## T2500D

**ELECTRICAL CHARACTERISTICS** ( $T_C = 25^\circ\text{C}$  unless otherwise noted; Electricals apply in both directions)

Characteristic	Symbol	Min	Typ	Max	Unit
----------------	--------	-----	-----	-----	------

**OFF CHARACTERISTICS**

Peak Repetitive Blocking Current $T_J = 25^\circ\text{C}$ (Rated $V_{DRM}$ , $V_{RRM}$ ; Gate Open) $T_J = 100^\circ\text{C}$	$I_{DRM}$ , $I_{RRM}$	-	-	10 2.0	$\mu\text{A}$ mA
--	--------------------------	---	---	-----------	---------------------

**ON CHARACTERISTICS**

Peak On-State Voltage (Note 2) ( $I_{TM} = \pm 30$ A Peak)	$V_{TM}$	-	-	2.0	V
Gate Trigger Current (Continuous dc) ( $V_D = 12$ Vdc, $R_L = 100 \Omega$ ) MT2(+), G(+) MT2(+), G(-) MT2(-), G(-) MT2(-), G(+)	$I_{GT}$	-	10 20 15 30	25 60 25 60	mA
Gate Trigger Voltage (Continuous dc) (All Four Quadrants) ( $V_D = 12$ Vdc, $R_L = 100 \Omega$ )	$V_{GT}$	-	1.25	2.5	V
Gate Non-Trigger Voltage ( $V_D = 12$ V, $R_L = 100 \Omega$ , $T_C = 100^\circ\text{C}$ )	$V_{GD}$	0.2	-	-	V
Holding Current (Main Terminal Voltage = 12 Vdc, Gate Open, Initiating Current = $\pm 200$ mA)	$I_H$	-	15	30	mA
Gate Controlled Turn-On Time (Rated $V_{DRM}$ , $I_T = 10$ A, $I_{GT} = 160$ mA, Rise Time = 0.1 $\mu\text{s}$ )	$t_{gt}$	-	1.6	-	$\mu\text{s}$

**DYNAMIC CHARACTERISTICS**

Critical Rate-of-Rise of Commutation Voltage (Rated $V_{DRM}$ , $I_{T(RMS)} = 6$ A, Commutating $di/dt = 3.2$ A/ms, Gate Unenergized, $T_C = 80^\circ\text{C}$ )	$dv/dt(c)$	-	10	-	V/ $\mu\text{s}$
Critical Rate-of-Rise of Off-State Voltage (Rated $V_{DRM}$ , Exponential Voltage Rise, Gate Open, $T_C = 100^\circ\text{C}$ )	$dv/dt$	-	75	-	V/ $\mu\text{s}$

 2. Pulse Test: Pulse Width  $\leq 2.0$  ms, Duty Cycle  $\leq 2\%$ .

**T2500D**

**Voltage Current Characteristic of Triacs  
(Bidirectional Device)**

Symbol	Parameter
$V_{DRM}$	Peak Repetitive Forward Off State Voltage
$I_{DRM}$	Peak Forward Blocking Current
$V_{RRM}$	Peak Repetitive Reverse Off State Voltage
$I_{RRM}$	Peak Reverse Blocking Current
$V_{TM}$	Maximum On State Voltage
$I_H$	Holding Current

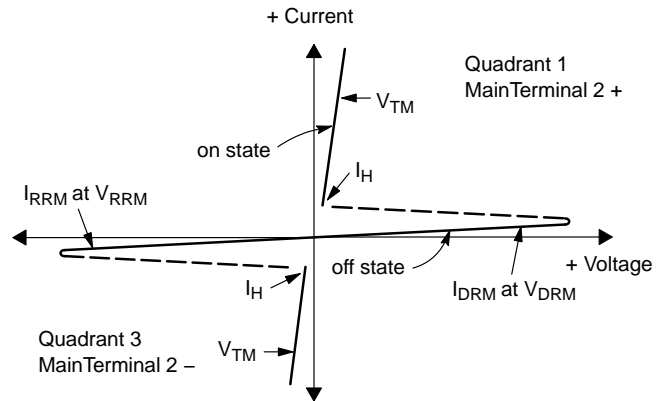

**Quadrant Definitions for a Triac**

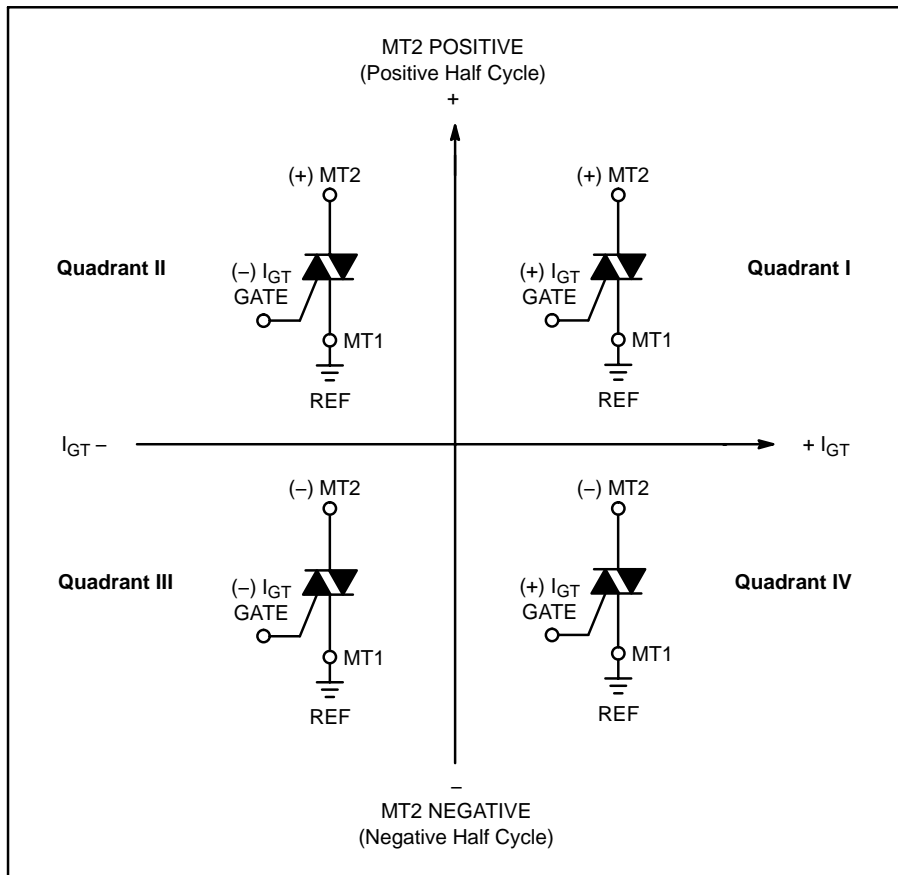

All polarities are referenced to MT1.  
With in-phase signals (using standard AC lines) quadrants I and III are used.

## T2500D

### PACKAGE DIMENSIONS

#### TO-220 CASE 221A-07 ISSUE AA

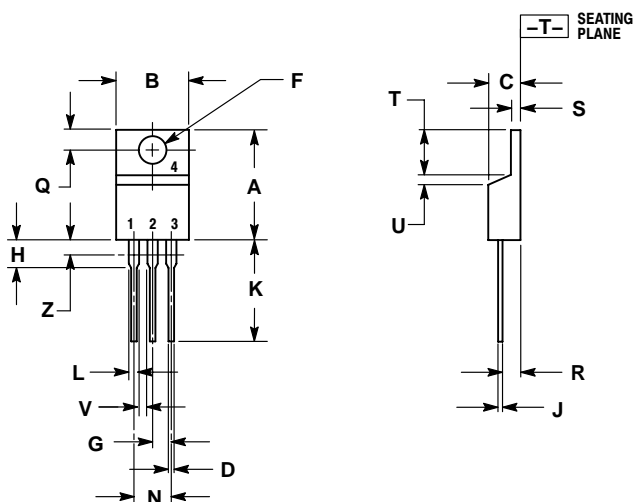

NOTES:

1. DIMENSIONING AND TOLERANCING PER ANSI Y14.5M, 1982.
2. CONTROLLING DIMENSION: INCH.
3. DIMENSION Z DEFINES A ZONE WHERE ALL BODY AND LEAD IRREGULARITIES ARE ALLOWED.

DIM	INCHES		MILLIMETERS	
	MIN	MAX	MIN	MAX
A	0.570	0.620	14.48	15.75
B	0.380	0.405	9.66	10.28
C	0.160	0.190	4.07	4.82
D	0.025	0.035	0.64	0.88
F	0.142	0.147	3.61	3.73
G	0.095	0.105	2.42	2.66
H	0.110	0.155	2.80	3.93
J	0.014	0.022	0.36	0.55
K	0.500	0.562	12.70	14.27
L	0.045	0.060	1.15	1.52
N	0.190	0.210	4.83	5.33
Q	0.100	0.120	2.54	3.04
R	0.080	0.110	2.04	2.79
S	0.045	0.055	1.15	1.39
T	0.235	0.255	5.97	6.47
U	0.000	0.050	0.00	1.27
V	0.045	---	1.15	---
Z	---	0.080	---	2.04

STYLE 4:

1. MAIN TERMINAL 1
2. MAIN TERMINAL 2
3. GATE
4. MAIN TERMINAL 2

ON Semiconductor and  are registered trademarks of Semiconductor Components Industries, LLC (SCILLC). SCILLC reserves the right to make changes without further notice to any products herein. SCILLC makes no warranty, representation or guarantee regarding the suitability of its products for any particular purpose, nor does SCILLC assume any liability arising out of the application or use of any product or circuit, and specifically disclaims any and all liability, including without limitation special, consequential or incidental damages. "Typical" parameters which may be provided in SCILLC data sheets and/or specifications can and do vary in different applications and actual performance may vary over time. All operating parameters, including "Typicals" must be validated for each customer application by customer's technical experts. SCILLC does not convey any license under its patent rights nor the rights of others. SCILLC products are not designed, intended, or authorized for use as components in systems intended for surgical implant into the body, or other applications intended to support or sustain life, or for any other application in which the failure of the SCILLC product could create a situation where personal injury or death may occur. Should Buyer purchase or use SCILLC products for any such unintended or unauthorized application, Buyer shall indemnify and hold SCILLC and its officers, employees, subsidiaries, affiliates, and distributors harmless against all claims, costs, damages, and expenses, and reasonable attorney fees arising out of, directly or indirectly, any claim of personal injury or death associated with such unintended or unauthorized use, even if such claim alleges that SCILLC was negligent regarding the design or manufacture of the part. SCILLC is an Equal Opportunity/Affirmative Action Employer. This literature is subject to all applicable copyright laws and is not for resale in any manner.

### PUBLICATION ORDERING INFORMATION

LITERATURE FULFILLMENT:

Literature Distribution Center for ON Semiconductor  
P.O. Box 61312, Phoenix, Arizona 85082-1312 USA  
Phone: 480-829-7710 or 800-344-3860 Toll Free USA/Canada  
Fax: 480-829-7709 or 800-344-3867 Toll Free USA/Canada  
Email: orderlit@onsemi.com

N. American Technical Support: 800-282-9855 Toll Free USA/Canada

Japan: ON Semiconductor, Japan Customer Focus Center  
2-9-1 Kamineguro, Meguro-ku, Tokyo, Japan 153-0051  
Phone: 81-3-5773-3850

ON Semiconductor Website: <http://onsemi.com>

Order Literature: <http://www.onsemi.com/litorder>

For additional information, please contact your local Sales Representative.