

## Excellent Integrated System Limited

Stocking Distributor

Click to view price, real time Inventory, Delivery & Lifecycle Information:

[RFMD](#)  
[SGA-0163](#)

For any questions, you can email us directly:  
[sales@integrated-circuit.com](mailto:sales@integrated-circuit.com)



rfmd.com

*Preliminary*

# SGA-0163(Z)

**DC to 4500MHz, SILICON GERMANIUM  
 CASCADABLE GAIN BLOCK**

RFMD Green, RoHS Compliant, Pb-Free (Z Part Number)  
 Package: SOT-363



## Product Description

The SGA-0163 is a high performance SiGe HBT MMIC Amplifier. A Darlington configuration featuring one-micron emitters provides high FT and excellent thermal performance. The heterojunction increases breakdown voltage and minimizes leakage current between junctions. Cancellation of emitter junction non-linearities results in higher suppression of intermodulation products. Only two DC-blocking capacitors, a bias resistor and an optional RF choke are required for operation.

## Features

- DC to 4500 MHz Operation
- Single Voltage Supply
- Low Current Draw: 8 mA at 2.1V typ.
- High Output Intercept: 10dBm Typ. at 1900MHz

## Applications

- PA Driver Amplifier
- Cellular, PCS, GSM, UMTS
- IF Amplifier
- Wireless Data, Satellite

### Optimum Technology Matching® Applied

- GaAs HBT
- GaAs MESFET
- InGaP HBT
- SiGe BiCMOS
- Si BiCMOS
- SiGe HBT
- GaAs pHEMT
- Si CMOS
- Si BJT
- GaN HEMT
- RF MEMS

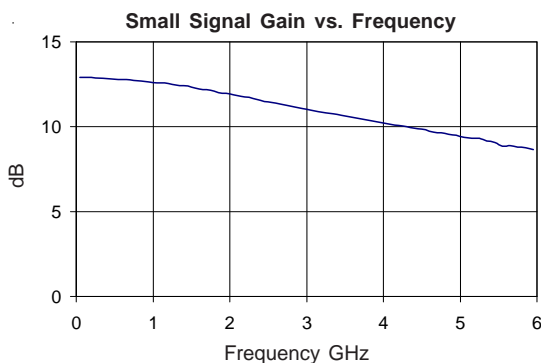

Parameter	Specification			Unit	Condition
	Min.	Typ.	Max.		
Output Power at 1dB Compression		-1.8		dBm	850MHz
		-1.8		dBm	1950MHz
		-2.4		dBm	2400MHz
Third Order Intercept Point		9.4		dBm	850MHz
		9.8		dBm	1950MHz
		9.2		dBm	2400MHz
Small Signal Gain		12.7		dB	850MHz
		12.0		dB	1950MHz
		11.6		dB	2400MHz
3dB Bandwidth		4500		MHz	
Input VSWR		1.6:1			DC to 4500MHz
Output VSWR		1.3:1			DC to 4500MHz
Reverse Isolation		17.6		dB	850MHz
		18.1		dB	1950MHz
		18.3		dB	2400MHz
Noise Figure <sup>[1]</sup>		4.6		dB	1950MHz
Device Operating Voltage		2.1		V	
Device Operating Current	6	8	10	mA	
Thermal Resistance		255		°C/W	junction - lead

Test Conditions: V<sub>S</sub> = 5V, I<sub>D</sub> = 8mA Typ., T<sub>L</sub> = 25°C. OIP3 Tone Spacing = 1MHz, P<sub>OUT</sub> per tone = -17dBm, R<sub>BIAS</sub> = 360Ω, Z<sub>S</sub> = Z<sub>L</sub> = 50Ω

RF MICRO DEVICES®, RFMD®, Optimum Technology Matching®, Enabling Wireless Connectivity™, PowerStar®, POLARIS™ TOTAL RADIO™ and UltimateBlue™ are trademarks of RFMD, LLC. BLUETOOTH is a trademark owned by Bluetooth SIG, Inc., U.S.A. and licensed for use by RFMD. All other trade names, trademarks and registered trademarks are the property of their respective owners. ©2006, RF Micro Devices, Inc.

# SGA-0163(Z)

Preliminary



rfmd.com

## Absolute Maximum Ratings

Parameter	Rating	Unit
Device Current (I <sub>D</sub> )	16	mA
Device Voltage (V <sub>D</sub> )	6	V
RF Input Power	-4	dBm
Junction Temp (T <sub>J</sub> )	+150	°C
Operating Temp Range (T <sub>L</sub> )	-40 to +85	°C
Storage Temp	+150	°C



Caution! ESD sensitive device.

Exceeding any one or a combination of the Absolute Maximum Rating conditions may cause permanent damage to the device. Extended application of Absolute Maximum Rating conditions to the device may reduce device reliability. Specified typical performance or functional operation of the device under Absolute Maximum Rating conditions is not implied.

RoHS status based on EUDirective2002/95/EC (at time of this document revision).

The information in this publication is believed to be accurate and reliable. However, no responsibility is assumed by RF Micro Devices, Inc. ("RFMD") for its use, nor for any infringement of patents, or other rights of third parties, resulting from its use. No license is granted by implication or otherwise under any patent or patent rights of RFMD. RFMD reserves the right to change component circuitry, recommended application circuitry and specifications at any time without prior notice.

Operation of this device beyond any one of these limits may cause permanent damage. For reliable continuous operation, the device voltage and current must not exceed the maximum operating values specified in the table on page one.

Bias Conditions should also satisfy the following expression:

$$I_D V_D < (T_J - T_L) / R_{TH, J-I}$$

Parameter	Specification			Unit	Condition
	Min.	Typ.	Max.		
Gain		12.9		dB	100MHz
		12.8		dB	500MHz
		12.7		dB	850MHz
		12.0		dB	1950MHz
		11.6		dB	2400MHz
Output IP <sub>3</sub>		10.6		dB	3500MHz
		9.4		dBm	100MHz, Tone spacing=1MHz, P <sub>OUT</sub> per tone=-17dBm
		9.5		dBm	500MHz, Tone spacing=1MHz, P <sub>OUT</sub> per tone=-17dBm
		9.4		dBm	850MHz, Tone spacing=1MHz, P <sub>OUT</sub> per tone=-17dBm
		9.8		dBm	1950MHz, Tone spacing=1MHz, P <sub>OUT</sub> per tone=-17dBm
Output P1dB		9.2		dBm	2400MHz, Tone spacing=1MHz, P <sub>OUT</sub> per tone=-17dBm
		9.3		dBm	3500MHz, Tone spacing=1MHz, P <sub>OUT</sub> per tone=-17dBm
		-1.5		dBm	100MHz
		-1.5		dBm	500MHz
		-1.8		dBm	850MHz
Input Return Loss		-1.8		dBm	1950MHz
		-2.5		dBm	2400MHz
		-2.7		dBm	3500MHz
		12.5		dB	100MHz
		12.7		dB	500MHz
Reverse Isolation		12.8		dB	850MHz
		12.4		dB	1950MHz
		12.1		dB	2400MHz
		11.8		dB	3500MHz
		17.3		dB	100MHz
Noise Figure		17.4		dB	500MHz
		17.6		dB	850MHz
		18.1		dB	1950MHz
		18.3		dB	2400MHz
		18.5		dB	3500MHz
Noise Figure		4.6		dB	100MHz, Z <sub>S</sub> =50Ω
		4.6		dB	500MHz, Z <sub>S</sub> =50Ω
		4.7		dB	850MHz, Z <sub>S</sub> =50Ω
		4.6		dB	1950MHz, Z <sub>S</sub> =50Ω

Test Conditions: I<sub>D</sub>=8mA, unless otherwise noted

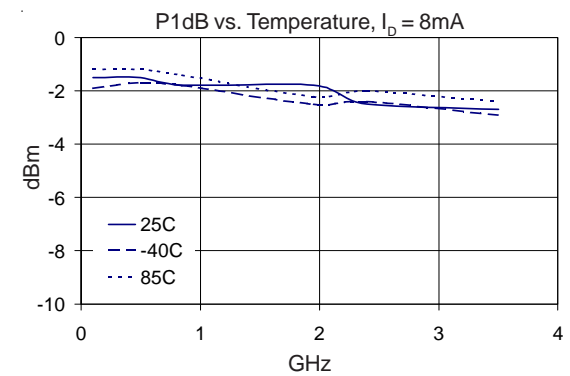
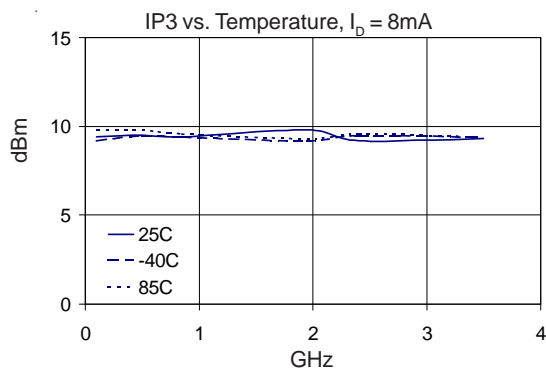
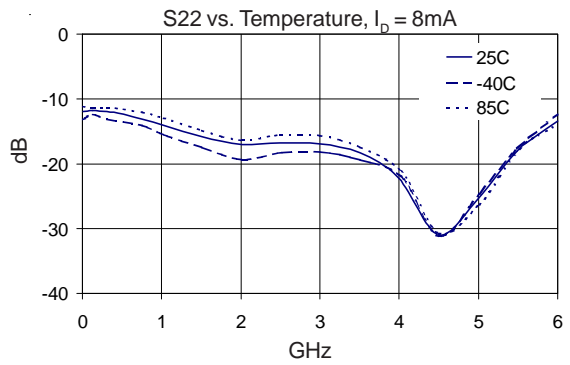
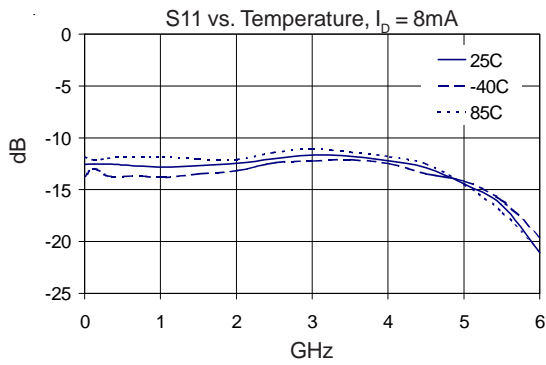
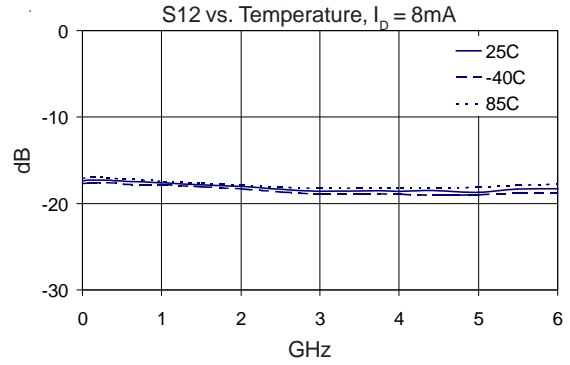
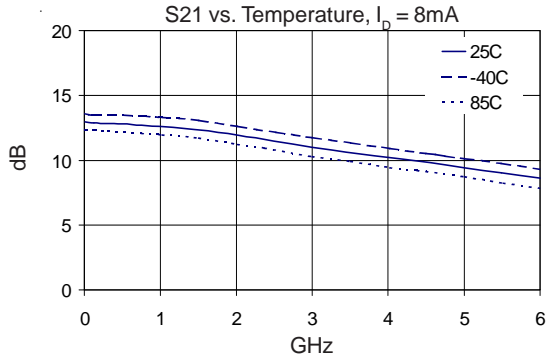

# SGA-0163(Z)

Preliminary



rfmd.com

Pin	Function	Description
3	RF IN	RF input pin. This pin requires the use of an external DC blocking capacitor chosen for the frequency of operation.
1, 2, 4, 5	GND	Connection to ground. Use via holes for best performance to reduce lead inductance as close to ground leads as possible.
6	RF OUT/BIAS	RF output and bias pin. DC voltage is present on this pin, therefore a DC blocking capacitor is necessary for proper operation.

## Suggested Pad Layout

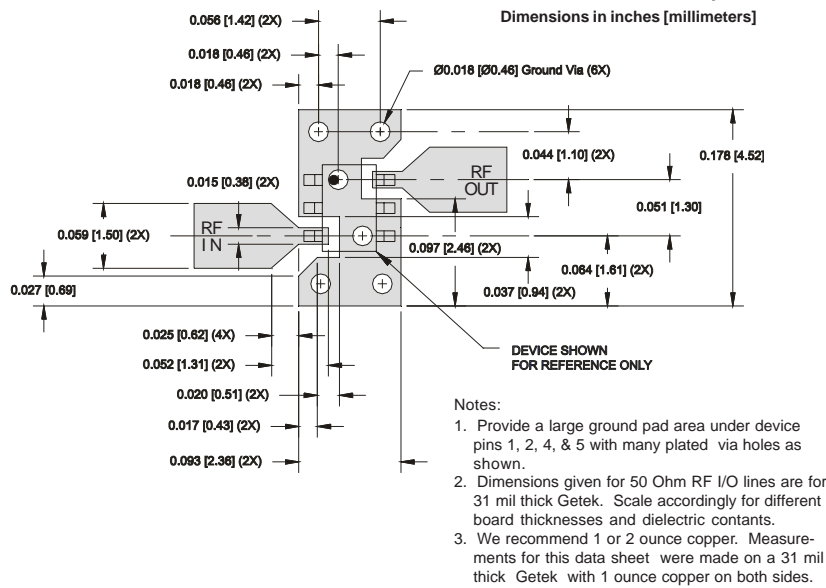

## Package Drawing

Dimensions in inches (millimeters)  
 Refer to drawing posted at [www.rfmd.com](http://www.rfmd.com) for tolerances.

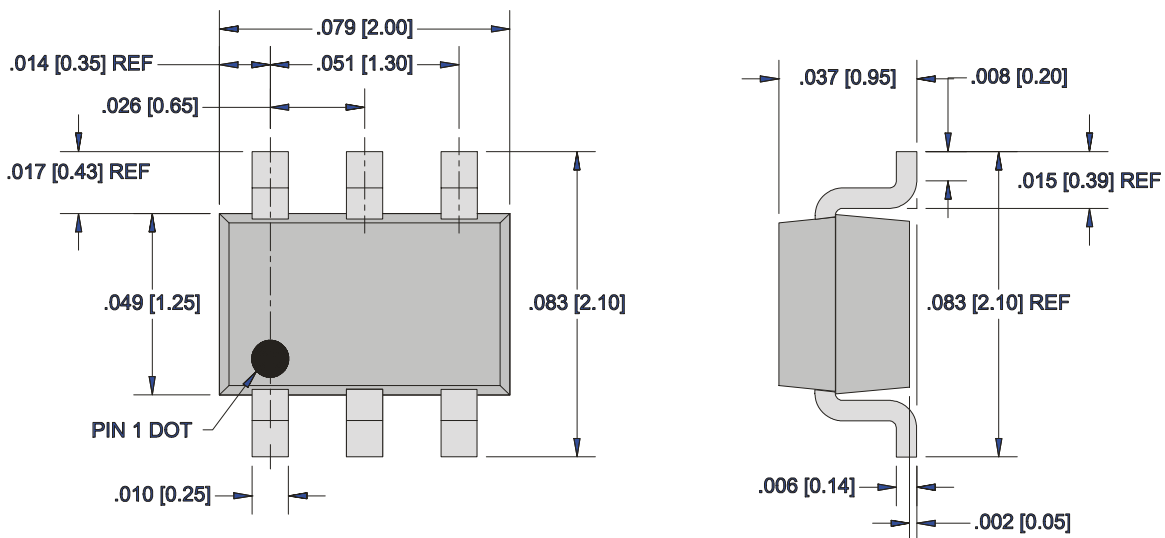

**Application Schematic**

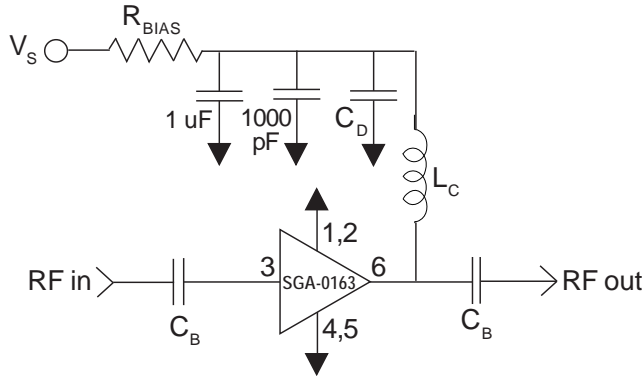

Reference Designator	Frequency (Mhz)				
	500	850	1950	2400	3500
C <sub>B</sub>	220 pF	100 pF	68 pF	56 pF	39 pF
C <sub>D</sub>	100 pF	68 pF	22 pF	22 pF	15 pF
L <sub>C</sub>	68 nH	33 nH	22 nH	18 nH	15 nH

Recommended Bias Resistor Values for I <sub>D</sub> =8mA				
$R_{BIAS} = (V_S - V_D) / I_D$				
Supply Voltage(V <sub>S</sub> )	5 V	7.5 V	9 V	12 V
R <sub>BIAS</sub>	360 Ω	680 Ω	820 Ω	1.2K Ω
Note: R <sub>BIAS</sub> provides DC bias stability over temperature.				

**Evaluation Board Layout**

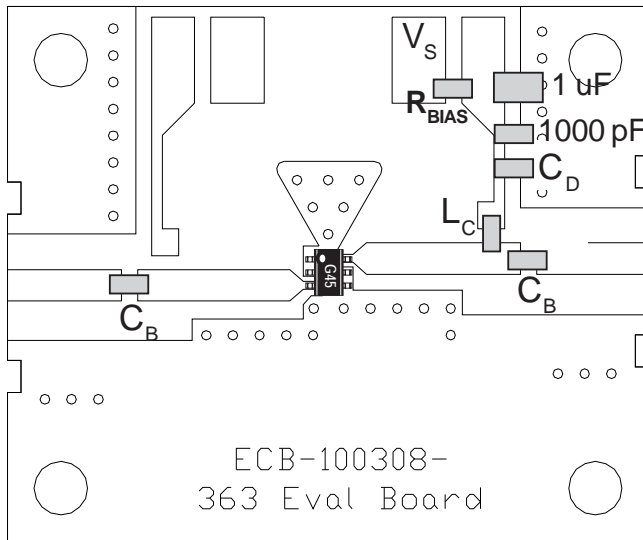

**Mounting Instructions**

1. Use a large ground pad area near device pins 1, 2, 4, and 5 with many plated through-holes as shown.
2. We recommend 1 or 2 ounce copper. Measurements for this data sheet were made on a 31 mil thick FR-4 board with 1 ounce copper on both sides.

# SGA-0163(Z)

*Preliminary*



## Part Identification Marking

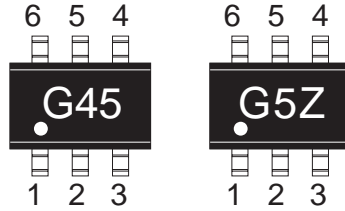

## Alternate Marking with Trace Code Only

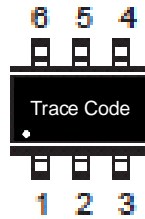

## Ordering Information

Part Number	Reel Size	Devices/Reel
SGA-0163	7"	3000
SGA-0163Z	7"	3000