

Excellent Integrated System Limited

Stocking Distributor

Click to view price, real time Inventory, Delivery & Lifecycle Information:

[Linear Technology](#)
[LM285Z-1.2#PBF](#)

For any questions, you can email us directly:

sales@integrated-circuit.com

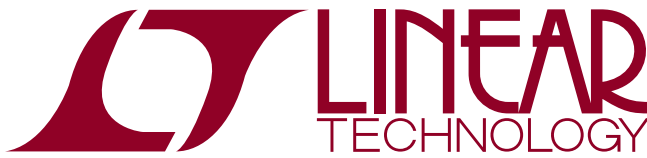

LM185-1.2/ LM285-1.2/LM385-1.2

Micropower Voltage Reference

FEATURES

- 10 μ A to 20mA Operating Range
- *Guaranteed* 1% Initial Voltage Tolerance
- *Guaranteed* 1 Ω Dynamic Impedance
- Very Low Power Consumption

APPLICATIONS

- Portable Meter References
- Portable Test Instruments
- Battery Operated Systems
- Current Loop Instrumentation

DESCRIPTION

The LM185-1.2 is a two terminal band gap reference diode that has been designed for applications which require precision performance with micropower operation. The device provides guaranteed operating specifications at currents as low as 10 μ A. The nominal voltage is 1.235V with both 1% and 2% tolerances available. Some additional features are: maximum dynamic impedance of 1 Ω , low noise and excellent stability over time and temperature. Advanced design, processing and testing techniques make Linear's LM185-1.2 a superior choice over previous designs. A micropower 5V reference application is shown below. For guaranteed TC, micropower references, see the LT1034 data sheet.

LT, LTC and LT are registered trademarks of Linear Technology Corporation.

TYPICAL APPLICATION

Micropower 5V Reference

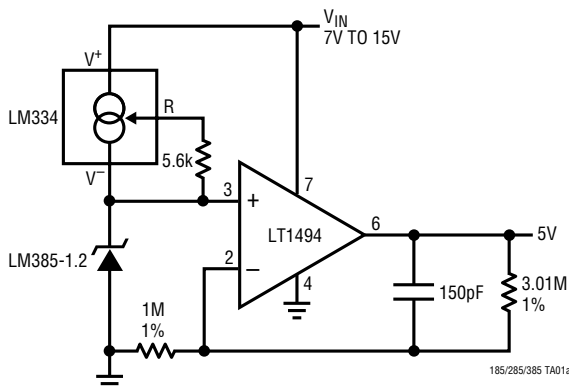

Reverse Voltage Change with Current

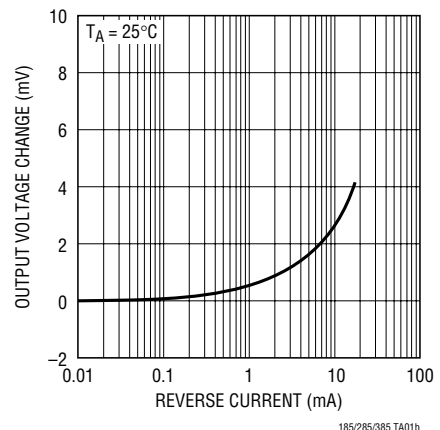

LM185-1.2/ LM285-1.2/LM385-1.2

ABSOLUTE MAXIMUM RATINGS

Operating Temperature Range

LM185-1.2(OBSOLETE) -55°C to 125°C

LM285-1.2 -40°C to 85°C

LM385-1.2 0°C to 70°C

Storage Temperature Range -65°C to 150°C

Lead Temperature (Soldering, 10 sec) 300°C

Reverse Breakdown Current 30mA

Forward Current 10mA

PACKAGE/ORDER INFORMATION

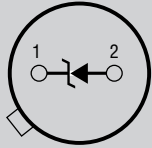
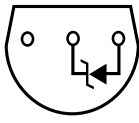
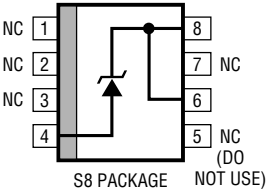
<p>BOTTOM VIEW</p>  <p>H PACKAGE 2-LEAD TO-46 METAL CAN $T_{JMAX} = 150^{\circ}C$, $\theta_{JA} = 440^{\circ}C/W$, $\theta_{JC} = 80^{\circ}C/W$ (NOTE 3)</p> <p>OBSOLETE PACKAGE Consider the S8 or Z Packages for Alternate Source</p>	<p>ORDER PART NUMBER</p> <p>LM185H-1.2 LM285H-1.2 LM385H-1.2 LM385BH-1.2</p>	<p>BOTTOM VIEW</p>  <p>Z PACKAGE 3-LEAD PLASTIC TO-92 $T_{JMAX} = 150^{\circ}C$, $\theta_{JA} = 160^{\circ}C/W$ (NOTE 3)</p>	<p>ORDER PART NUMBER</p> <p>LM285Z-1.2 LM385Z-1.2 LM385BZ-1.2</p>
<p>TOP VIEW</p>  <p>S8 PACKAGE NOT USE 8-LEAD PLASTIC SO $T_{JMAX} = 150^{\circ}C$, $\theta_{JA} = 190^{\circ}C/W$</p>		<p>ORDER PART NUMBER</p> <p>LM385BS8-1.2 LM385S8-1.2</p> <p>S8 PART MARKING</p> <p>3851 3851B</p>	

Consult LTC Marketing for parts specified with wider operating temperature ranges.

LM185-1.2/ LM285-1.2/LM385-1.2

ELECTRICAL CHARACTERISTICS

The ● denotes the specifications which apply over the full operating temperature range, otherwise specifications are at $T_A = 25^\circ\text{C}$. For the LM185-1.2 $T_{\text{MIN}} = -55^\circ\text{C}$ and $T_{\text{MAX}} = 125^\circ\text{C}$. For LM285-1.2 $T_{\text{MIN}} = -40^\circ\text{C}$ and $T_{\text{MAX}} = 85^\circ\text{C}$. For LM385-1.2 $T_{\text{MIN}} = 0^\circ\text{C}$ and $T_{\text{MAX}} = 70^\circ\text{C}$. For MIL-STD components, please refer to LTC883C data sheet for test listing and parameters.

SYMBOL	PARAMETER	CONDITIONS	LM185-1.2/LM285-1.2			LM385-1.2/LM385B-1.2			UNITS
			MIN	TYP	MAX	MIN	TYP	MAX	
V_Z	Reverse Breakdown Voltage	$T_A = 25^\circ\text{C}$, $I_{\text{MIN}} \leq I_R \leq 20\text{mA}$ LM185-1.2 LM385-1.2 LM385B-1.2 (Note 3)	1.223	1.235	1.247	1.205	1.235	1.260	V
$\frac{\Delta V_Z}{\Delta \text{Temp}}$	Average Temperature Coefficient	$I_{\text{MIN}} \leq I_R \leq 20\text{mA}$ (Notes 2, 3)	20			20			ppm/ $^\circ\text{C}$
I_{MIN}	Minimum Operating Current	$T_{\text{MIN}} \leq T_A \leq T_{\text{MAX}}$	●	8	10	8	15		μA
$\frac{\Delta V_Z}{\Delta I_R}$	Reverse Breakdown Voltage Change with Current	$I_{\text{MIN}} \leq I_R \leq 1\text{mA}$ $T_A = 25^\circ\text{C}$ $T_{\text{MIN}} \leq T_A \leq T_{\text{MAX}}$	●		1		1		mV
		$1\text{mA} \leq I_R \leq 20\text{mA}$ $T_A = 25^\circ\text{C}$ $T_{\text{MIN}} \leq T_A \leq T_{\text{MAX}}$	●		1.5		1.5		mV
		$1\text{mA} \leq I_R \leq 20\text{mA}$ $T_A = 25^\circ\text{C}$ $T_{\text{MIN}} \leq T_A \leq T_{\text{MAX}}$	●		10		10		mV
r_Z	Reverse Dynamic Impedance	$I_R = 100\mu\text{A}$ $T_A = 25^\circ\text{C}$ $T_{\text{MIN}} \leq T_A \leq T_{\text{MAX}}$	●	0.2	0.6	0.4	1.0		Ω
					1.5		1.5		Ω
e_n	Wideband Noise (RMS)	$I_R = 100\mu\text{A}$, $10\text{Hz} \leq f \leq 10\text{kHz}$		60		60			μV
$\frac{\Delta V_Z}{\Delta \text{Time}}$	Long Term Stability	$I_R = 100\mu\text{A}$, $T_A = 25^\circ\text{C} \pm 0.1^\circ\text{C}$		20		20			ppm/kHr

Note 1: Absolute Maximum Ratings are those values beyond which the life of a device may be impaired.

Note 2: Selected devices with guaranteed maximum temperature coefficient are available upon request.

Note 3: For applications requiring low initial tolerance guaranteed over temperature consult the LT1004 data sheet.

LM185-1.2/ LM285-1.2/LM385-1.2

TYPICAL PERFORMANCE CHARACTERISTICS

Reverse Characteristics

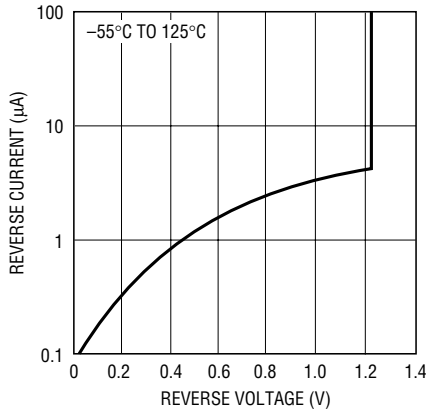

185/285/385 G01

Forward Characteristics

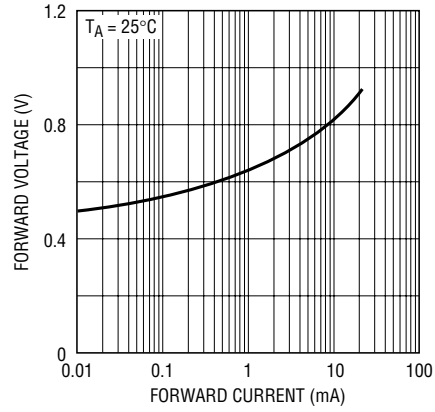

185/285/385 G02

Temperature Drift

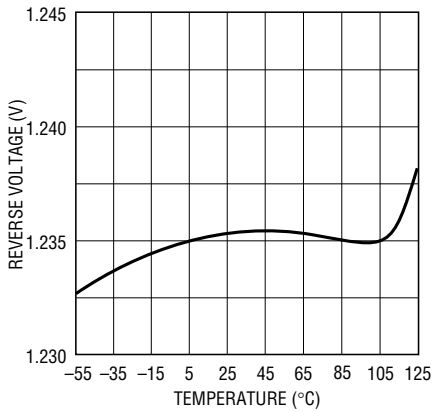

185/285/385 G03

Reverse Dynamic Impedance

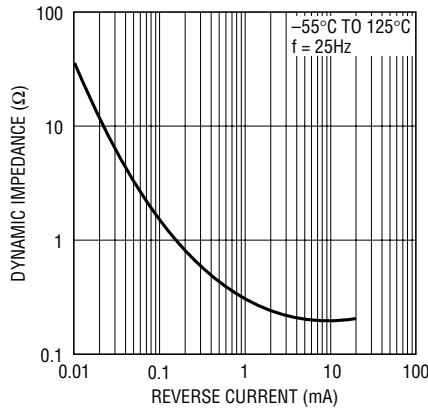

185/285/385 G04

Reverse Dynamic Impedance

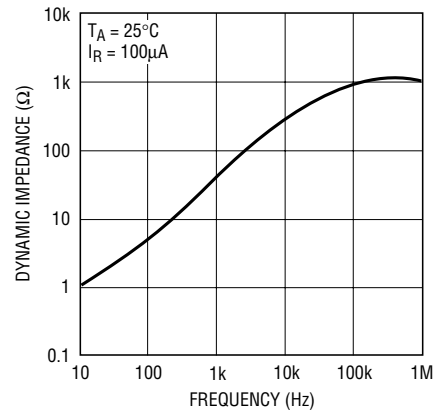

185/285/385 G05

Noise Voltage

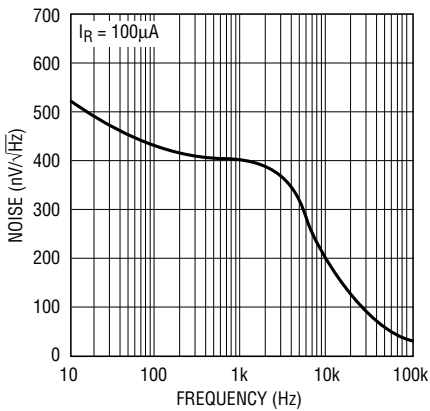

185/285/385 G06

Filtered Output Noise

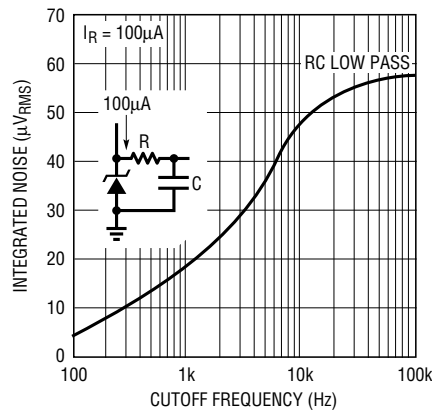

185/285/385 G07

Response Time

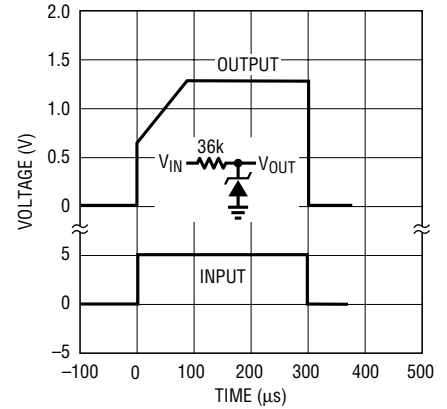

185/285/385 G08

LM185-1.2/
LM285-1.2/LM385-1.2

SCHEMATIC DIAGRAM

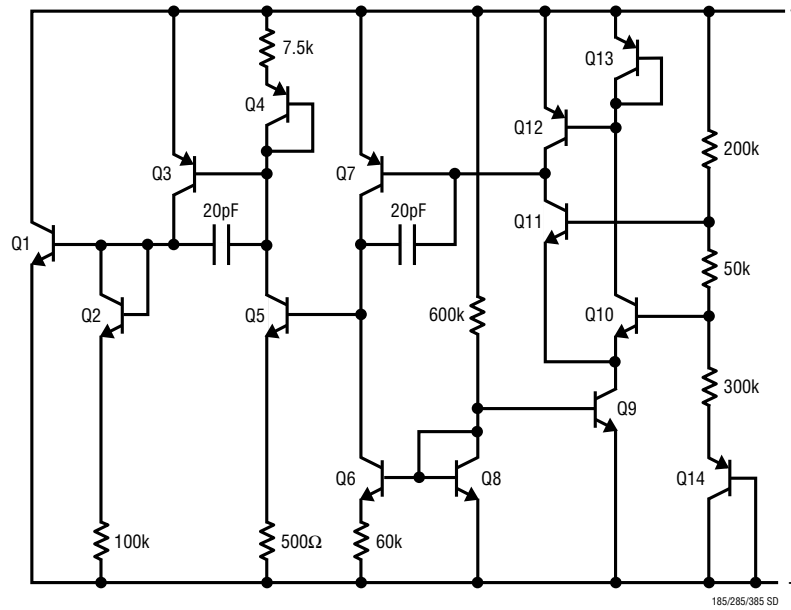

LM185-1.2/ LM285-1.2/LM385-1.2

PACKAGE DESCRIPTION

H Package 2-Lead and 3-Lead TO-46 Metal Can (Reference LTC DWG # 05-08-1340)

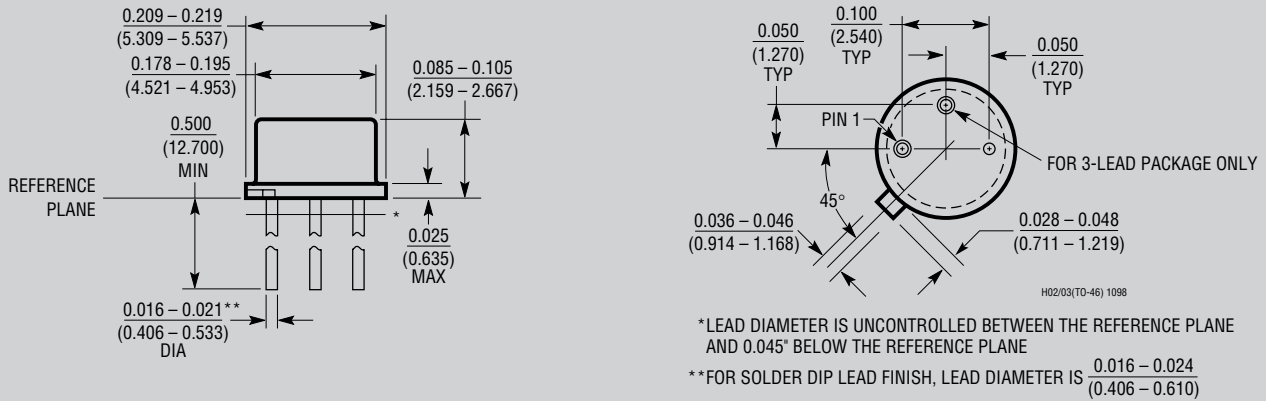

OBSOLETE PACKAGE

Z Package 3-Lead Plastic TO-92 (Similar to TO-226) (Reference LTC DWG # 05-08-1410)

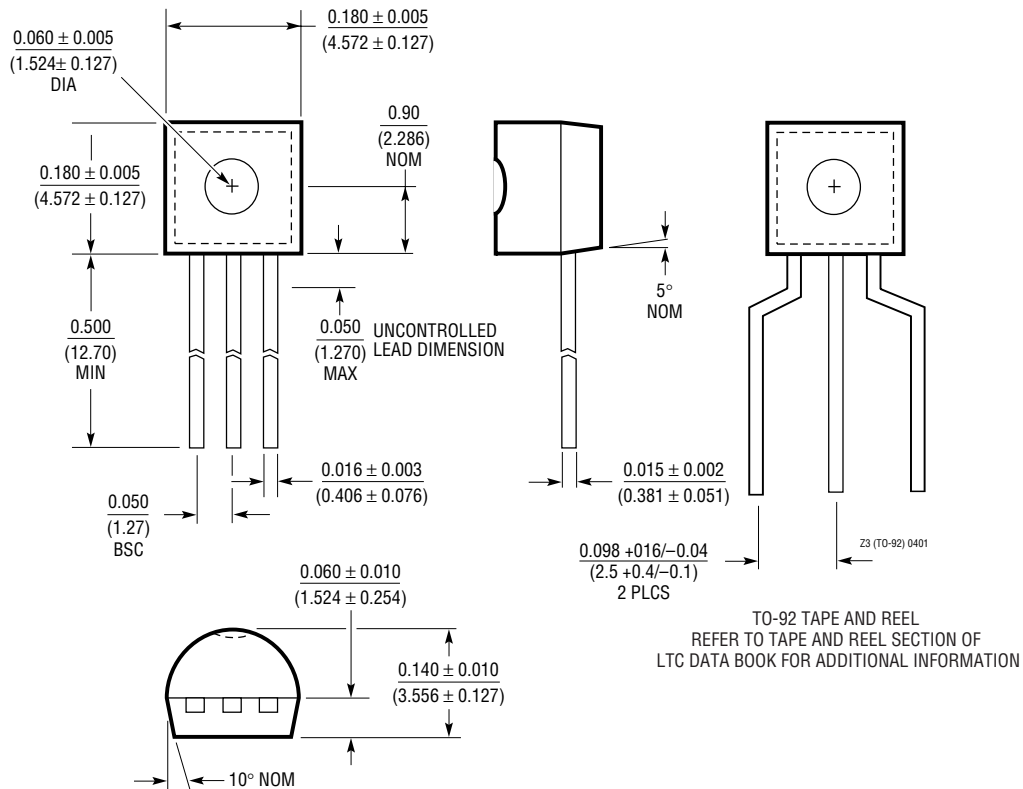

LM185-1.2/
LM285-1.2/LM385-1.2

PACKAGE DESCRIPTION

S8 Package
8-Lead Plastic Small Outline (Narrow .150 Inch)
(Reference LTC DWG # 05-08-1610)

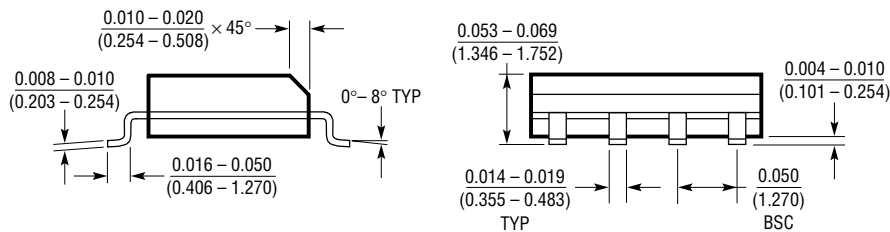
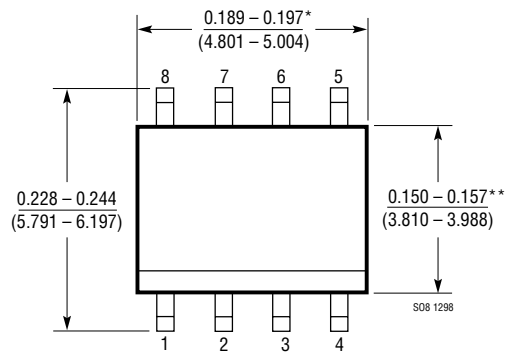

DIMENSION DOES NOT INCLUDE MOLD FLASH. MOLD FLASH SHALL NOT EXCEED 0.006 (0.152mm) PER SIDE

**DIMENSION DOES NOT INCLUDE INTERLEAD FLASH. INTERLEAD FLASH SHALL NOT EXCEED 0.010* (0.254mm) PER SIDE

LM185-1.2/ LM285-1.2/LM385-1.2

TYPICAL APPLICATIONS

Micropower Reference for 9V Battery

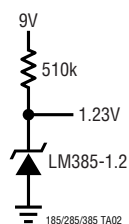

1.2V Reference from 1.5V Battery

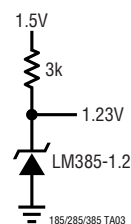

RELATED PARTS

PART NUMBER	DESCRIPTION	COMMENTS
LT1004-1.2	Micropower Shunt Reference	0.3% Initial Accuracy
LT1034	1.2V Micropower Shunt Reference	40ppm/°C Max Temperature Coefficient