

Excellent Integrated System Limited

Stocking Distributor

Click to view price, real time Inventory, Delivery & Lifecycle Information:

[Linear Technology](#)
[OP16GN8#PBF](#)

For any questions, you can email us directly:

sales@integrated-circuit.com



OP-15/OP-16

Precision, High Speed JFET-Input Operational Amplifiers

FEATURES

- Improved Specifications Compared to LF155/156 Devices
- *Guaranteed* Low Offset Voltage 500 μ V Max.
- *Guaranteed* Low Offset Drift 5 μ V/ $^{\circ}$ C Max.
- *Guaranteed* Bias Current Fully Warmed-Up over Temperature
- OP-15: LF156 Speed with LF155 Power Dissipation
 - Guaranteed* Supply Current 4mA Max.
 - Guaranteed* Slew Rate 10V/ μ s Min.
- OP-16:
 - Guaranteed* Faster Slew Rate 18V/ μ s Min.
 - No High Frequency Oscillation at Cold Temperatures
- No Phase Reversal when Negative Common-Mode Limit is Exceeded

APPLICATIONS

- Long Term Precision Integration
- Current to Voltage Conversion
- Medical Instrumentation—CAT Scanner
- High Speed, Precision Sample and Hold

DESCRIPTION

The OP-15/16 series devices feature distinct advantages over other JFET-input operational amplifiers, in particular compared to LF155/156 types.

The OP-15 has the speed of the LF156 design with the low power dissipation of the slower LF155. The OP-16 is considerably faster. Both devices offer offset voltages as low as 0.5mV, with guaranteed drift of 5 μ V/ $^{\circ}$ C. Input bias current at 125 $^{\circ}$ C is just a few nanoamperes.

Other manufacturers' OP-15/16 (and LF155/156) exhibit phase reversal at the output when the negative common-mode limit at the input is exceeded; i.e., driving from -12V to -15V with \pm 15V supplies. This can cause lock-up in servo systems. As shown in the application section, Linear Technology's OP-15/16 does not have this problem due to unique phase reversal protection circuitry.

In addition, Linear's OP-16 is free from high frequency oscillation problems at cold temperatures, as is illustrated in the "Voltage Follower Small Signal Pulse Response" photo. For applications requiring higher performance, see the LT1022, LT1055 and LT1056 data sheets.

2

Fast, 12-Bit Current Comparator

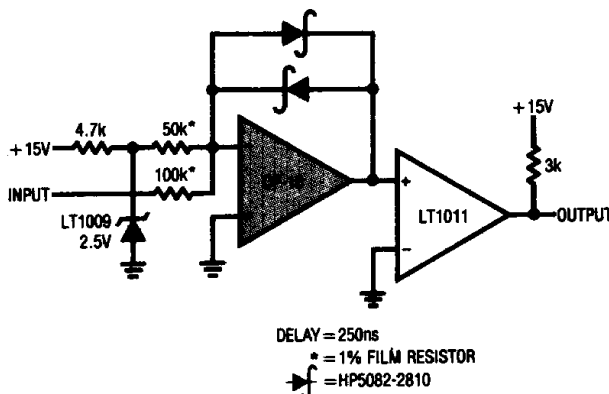

Voltage Follower Small Signal Pulse Response
 $T_A = -55^{\circ}\text{C}$

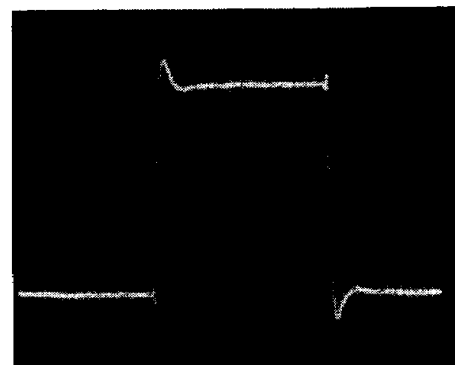

$C_L = 100\text{pF}$
 VERTICAL SCALE = 20mV/DIV
 HORIZONTAL SCALE = 0.2 μ s/DIV

OP-15/OP-16

ABSOLUTE MAXIMUM RATINGS

Supply Voltage	
A, B, E, F Grades	± 22V
C, G Grades	± 18V
Internal Power Dissipation	500mW
Operating Temperature Range	
A, B, C Grades	-55°C to 125°C
E, F, G Grades	0°C to 70°C
Junction Temperature	150°C
Differential Input Voltage	
A, B, E, F Grades	± 40V
C, G Grades	± 30V
Input Voltage (Note 4)	
A, B, E, F Grades	± 20V
C, G Grades	± 16V
Output Short Circuit Duration	Indefinite
Storage Temperature Range	-65°C to 150°C
Lead Temperature (Soldering, 10 sec.)	300°C

PACKAGE/ORDER INFORMATION

<p>TOP VIEW NC 8 V_{OS} TRIM 1 V⁺ 7 -IN 2 OUT 6 +IN 3 V_{OS} TRIM 5 V⁻ (CASE) 4 H PACKAGE METAL CAN</p>	ORDER PART NUMBER	
	OP-15AH	OP-16AH
<p>TOP VIEW V_{OS} TRIM 1 -IN 2 +IN 3 V⁻ 4 NC 8 V⁺ 7 OUT 6 V_{OS} TRIM 5 NB PACKAGE 8 PIN PLASTIC DIP</p>	OP-15BH	OP-16BH
	OP-15CH	OP-16CH
	OP-15EH	OP-16EH
	OP-15FH	OP-16FH
	OP-15GH	OP-16GH
	OP-15GN8	OP-16GN8
V _{OS} is adjusted with a potentiometer ranging from 10k to 1M. The wiper is connected to V ⁺		

ELECTRICAL CHARACTERISTICS V_S = ± 15V, T_A = 25°C unless otherwise noted.

SYMBOL	PARAMETER	CONDITIONS	OP-15A/E OP-16A/E			OP-15B/F OP-16B/F			OP-15C/G OP-16C/G			UNITS
			MIN	TYP	MAX	MIN	TYP	MAX	MIN	TYP	MAX	
V _{OS}	Input Offset Voltage	R _S = 50Ω	—	0.2	0.5	—	0.4	1.0	—	0.5	3.0	mV
I _{OS}	Input Offset Current	T _J = 25°C (Note 1) Warmed-Up OP-15 OP-16	—	3	10	—	6	20	—	12	50	pA
I _B	Input Bias Current	T _J = 25°C (Note 1) Warmed-Up OP-15 OP-16	—	± 15	± 50	—	± 30	± 100	—	± 60	± 200	pA
			—	± 18	± 110	—	± 40	± 200	—	± 80	± 400	pA
			—	± 20	± 130	—	± 40	± 250	—	± 80	± 500	pA
R _{IN}	Input Resistance		—	10 ¹²	—	—	10 ¹²	—	—	10 ¹²	—	Ω
A _{VOL}	Large Signal Voltage Gain	R _L ≥ 2kΩ V _O = ± 10V	100	240	—	75	220	—	50	200	—	V/mV
V _O	Output Voltage Swing	R _L = 10kΩ R _L = 2kΩ	± 12	± 13	—	± 12	± 13	—	± 12	± 13	—	V
			± 11	± 12.7	—	± 11	± 12.7	—	± 11	± 12.7	—	V
I _S	Supply Current	OP-15 OP-16	—	2.7	4.0	—	2.7	4.0	—	2.8	5.0	mA
			—	4.6	7.0	—	4.6	7.0	—	4.8	8.0	mA
SR	Slew Rate	A _{VCL} = +1 OP-15 OP-16	10	13	—	7.5	11	—	5	9	—	V/μs
			18	20	—	12	18	—	9	16	—	V/μs
GBW	Gain Bandwidth Product	(Note 3) OP-15 OP-16	4.0	6.0	—	3.5	5.7	—	3.0	5.4	—	MHz
			—	8.0	—	—	7.6	—	—	7.2	—	MHz
	Settling Time (Note 2)	to 0.01% to 0.10%	—	4.5	—	—	4.5	—	—	4.7	—	μs
			—	1.2	—	—	1.2	—	—	1.3	—	μs
		to 0.01% to 0.10%	—	3.8	—	—	3.8	—	—	4.0	—	μs
			—	0.9	—	—	0.9	—	—	1.0	—	μs
	Input Voltage Range		± 10.5	—	—	± 10.5	—	—	± 10.3	—	—	V
CMRR	Common-Mode Rejection Ratio	V _{CM} = ± 10.5V V _{CM} = ± 10.3V	86	100	—	86	100	—	—	—	—	dB
			—	—	—	—	—	—	82	96	—	dB
PSRR	Power Supply Rejection Ratio	V _S = ± 10V to ± 18V V _S = ± 10V to ± 15V	—	10	51	—	10	51	—	—	—	μV/V
			—	—	—	—	—	—	—	10	80	μV/V
e _n	Input Noise Voltage Density	f ₀ = 100Hz f ₀ = 1000Hz	—	20	—	—	20	—	—	20	—	nV/√Hz
			—	15	—	—	15	—	—	15	—	nV/√Hz
i _n	Input Noise Current Density	f ₀ = 100Hz f ₀ = 1000Hz	—	0.01	—	—	0.01	—	—	0.01	—	pA/√Hz
			—	0.01	—	—	0.01	—	—	0.01	—	pA/√Hz
C _{IN}	Input Capacitance		—	3	—	—	3	—	—	3	—	pF

OP-15/OP-16

ELECTRICAL CHARACTERISTICS $V_S = \pm 15V, -55^\circ C \leq T_A \leq 125^\circ C$ unless otherwise noted.

SYMBOL	PARAMETER	CONDITIONS		OP-15A OP-16A			OP-15B OP-16B			OP-15C OP-16C			UNITS
				MIN	TYP	MAX	MIN	TYP	MAX	MIN	TYP	MAX	
V_{OS}	Input Offset Voltage	$R_S = 50\Omega$	●	—	0.4	0.9	—	0.7	2.0	—	0.9	4.5	mV
TCV_{OS}	Average Input Offset Voltage Drift Without External Trim		●	—	2	5	—	3	10	—	4	15	$\mu V/^\circ C$
			●	—	2	—	—	3	—	—	4	—	$\mu V/^\circ C$
I_{OS}	Input Offset Current	$T_J = 125^\circ C$ (Note 1) $T_A = 125^\circ C$, Warm-Up	OP-15 ●	—	0.6	4.0	—	0.8	6.0	—	1.0	9.0	nA
			OP-16 ●	—	0.8	7.0	—	1.2	11	—	1.5	17	nA
			OP-16 ●	—	1.0	8.5	—	1.3	14.5	—	1.7	22	nA
I_B	Input Bias Current	$T_J = 125^\circ C$ (Note 1) $T_A = 125^\circ C$, Warm-Up	OP-15 ●	—	± 1.2	± 5.0	—	± 1.5	± 7.5	—	± 1.8	± 10	nA
			OP-15 ●	—	± 1.7	± 9.0	—	± 2.2	± 14	—	± 2.7	± 19	nA
			OP-16 ●	—	± 2.0	± 11	—	± 2.5	± 18	—	± 3.0	± 25	nA
	Input Voltage Range		●	± 10.4	—	—	± 10.4	—	—	± 10.25	—	—	V
CMRR	Common-Mode Rejection Ratio	$V_{CM} = \pm 10.4V$ $V_{CM} = \pm 10.25V$	●	85	97	—	85	97	—	—	—	—	dB
			●	—	—	—	—	—	—	80	93	—	dB
PSRR	Power Supply Rejection Ratio	$V_S = \pm 10V$ to $\pm 18V$ $V_S = \pm 10V$ to $\pm 15V$	●	—	15	57	—	15	57	—	—	—	$\mu V/V$
			●	—	—	—	—	—	—	—	23	100	$\mu V/V$
A_{VOL}	Large Signal Voltage Gain	$R_L \geq 2k\Omega$ $V_O = \pm 10V$	●	35	120	—	30	110	—	25	100	—	V/mV
V_O	Output Voltage Swing	$R_L \geq 10k\Omega$	●	± 12	± 13	—	± 12	± 13	—	± 12	± 13	—	V

2

ELECTRICAL CHARACTERISTICS $V_S = \pm 15V, 0^\circ C \leq T_A \leq 70^\circ C$ unless otherwise noted.

SYMBOL	PARAMETER	CONDITIONS		OP-15E OP-16E			OP-15F OP-16F			OP-15G OP-16G			UNITS
				MIN	TYP	MAX	MIN	TYP	MAX	MIN	TYP	MAX	
V_{OS}	Input Offset Voltage	$R_S = 50\Omega$	●	—	0.3	0.75	—	0.55	1.5	—	0.7	3.8	mV
TCV_{OS}	Average Input Offset Voltage Drift Without External Trim		●	—	2	5	—	3	10	—	4	15	$\mu V/^\circ C$
			●	—	2	—	—	3	—	—	4	—	$\mu V/^\circ C$
I_{OS}	Input Offset Current	$T_J = 70^\circ C$ (Note 1) $T_A = 70^\circ C$, Warm-Up	OP-15 ●	—	0.04	0.30	—	0.06	0.45	—	0.08	0.65	nA
			OP-16 ●	—	0.06	0.55	—	0.08	0.80	—	0.10	1.2	nA
			OP-16 ●	—	0.07	0.70	—	0.10	1.1	—	0.15	1.7	nA
I_B	Input Bias Current	$T_J = 70^\circ C$ (Note 1) $T_A = 70^\circ C$, Warm-Up	OP-15 ●	—	± 0.10	± 0.40	—	± 0.12	± 0.60	—	± 0.14	± 0.80	nA
			OP-15 ●	—	± 0.13	± 0.75	—	± 0.16	± 1.1	—	± 0.19	± 1.5	nA
			OP-16 ●	—	± 0.15	± 0.90	—	± 0.20	± 1.4	—	± 0.25	± 2.0	nA
	Input Voltage Range		●	± 10.4	—	—	± 10.4	—	—	± 10.25	—	—	V
CMRR	Common-Mode Rejection Ratio	$V_{CM} = \pm 10.4V$ $V_{CM} = \pm 10.25V$	●	85	98	—	85	98	—	—	—	—	dB
			●	—	—	—	—	—	—	80	94	—	dB
PSRR	Power Supply Rejection Ratio	$V_S = \pm 10V$ to $\pm 18V$ $V_S = \pm 10V$ to $\pm 15V$	●	—	13	57	—	13	57	—	—	—	$\mu V/V$
			●	—	—	—	—	—	—	—	20	100	$\mu V/V$
A_{VD}	Large Signal Voltage Gain	$R_L \geq 2k\Omega$ $V_O = \pm 10V$	●	65	200	—	50	180	—	35	160	—	V/mV
V_O	Output Voltage Swing	$R_L \geq 10k\Omega$	●	± 12	± 13	—	± 12	± 13	—	± 12	± 13	—	V

The ● denotes the specifications which apply over full operating temperature range.

For MIL-STD components, please refer to LTC 883C data sheet for test listing and parameters.

Note 1: Input bias current is specified for two different conditions. The I_B specification is with the junction at ambient temperature; the warmed-up specification is with the device operating in a warmed-up condition at the ambient temperature specified. I_B and I_{OS} are measured at $V_{CM} = 0$.

Note 2: Settling time is defined here for a unity gain inverter connection using $2k\Omega$ resistors. It is the time required for the error voltage (the voltage at the inverting input pin on the amplifier) to settle to within a specified percentage of its final value from the time a 10V step input is applied to the inverter.

Note 3: Sample tested.

Note 4: Unless otherwise specified, the absolute maximum negative input voltage is equal to the negative power supply voltage.

OP-15/OP-16

APPLICATIONS

Voltage Follower with Input Exceeding the Negative Common-Mode Range

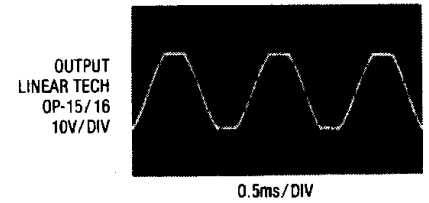
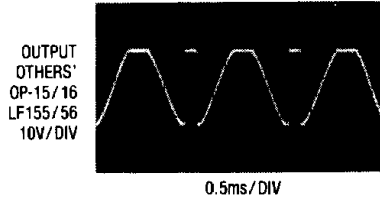
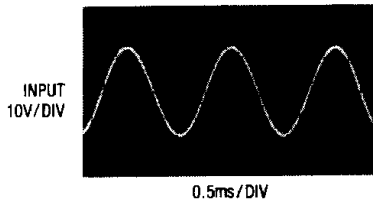
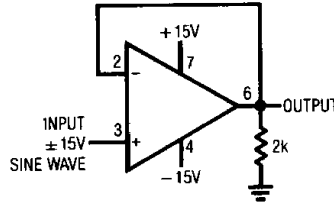

PACKAGE DESCRIPTION

H Package Metal Can

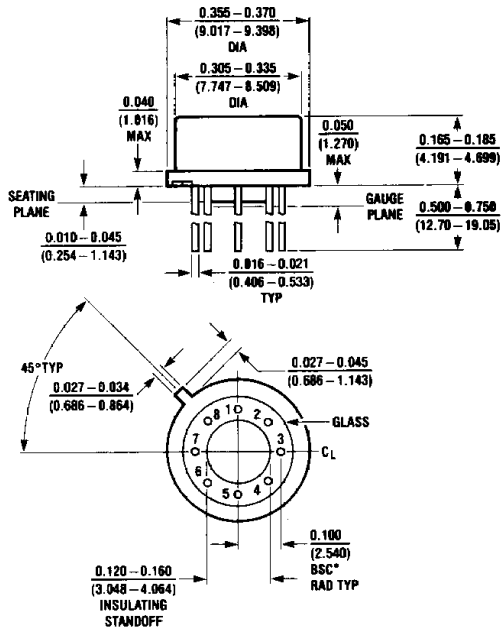

T_{jmax}	$\theta_{j\alpha}$	θ_{jc}
150°C	150°C/W	45°C/W

N8 Package 8 Lead Plastic

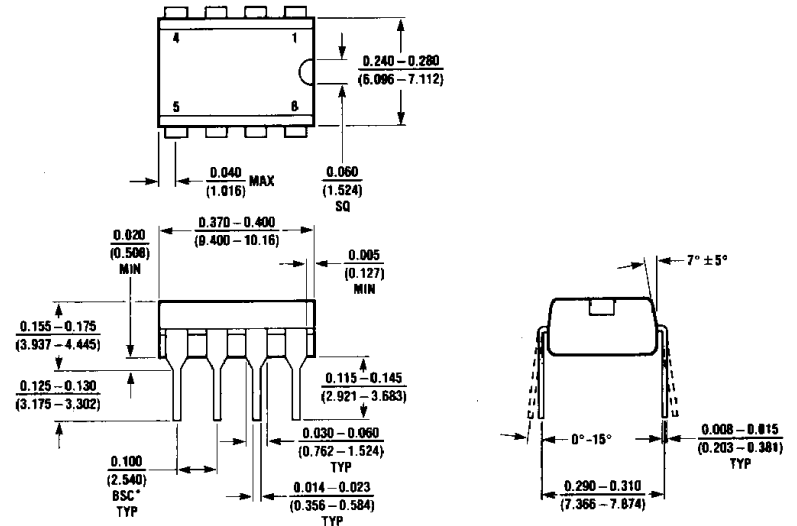

T_{jmax}	$\theta_{j\alpha}$
100°C	130°C/W