

## Excellent Integrated System Limited

Stocking Distributor

Click to view price, real time Inventory, Delivery & Lifecycle Information:

[Diodes Incorporated](#)  
[ZLNB100N8TC](#)

For any questions, you can email us directly:

[sales@integrated-circuit.com](mailto:sales@integrated-circuit.com)

## DUAL POLARISATION SWITCH TWIN LNB MULTIPLEX CONTROLLER

# ZLNB100

ISSUE 1- NOVEMBER 1998

### DEVICE DESCRIPTION

The ZLNB101 dual polarisation switch controller is one of a wide range of satellite receiver LNB support circuits. It features two completely independent channels, each providing two logic outputs under the control of a voltage sensitive input. It is intended for use in Twin LNB designs, replacing many discrete components to save both manufacturing cost and PCB size whilst improving reliability.

The two inputs of the ZLNB101 have a nominal threshold of 14.5V. Their threshold is temperature compensated to minimise drift. Each features a low and stable input current that enables transient protection to be achieved with the addition of only a single resistor per channel.

Normal and an inverted outputs are provided for each input. All outputs can source 15mA and sink 10mA making them suitable to drive TTL and CMOS logic, pin diodes and for IF-amp supply switching.

The ZLNB101 operates from a single supply of between 5-12V. Its quiescent current is typically only 4mA and this does not change significantly with load or logic state. It is available in either the standard SO8 or space saving MSOP8 surface mount packages. Device operating temperature is -40°C to +85°C to suit a wide range of environmental conditions.

### FEATURES

- provides polarity detection and control
- transient resistant
- low input current
- low supply current
- temperature compensated input threshold
- standard and inverted output available simultaneously wide supply operating range
- dual polarisation switch
- eliminates external components
- simplifies design

### APPLICATIONS

- twin LNBS
- IF switch box
- LNB switch boxes

# ZLNB100

**ABSOLUTE MAXIMUM RATINGS**

|  |                |
|--|----------------|
| Supply Voltage   | -0.6V to 15V   |
| Supply Current   | 50mA           |
| V <sub>POL1</sub> and V <sub>POL2</sub><br>Input Voltage | 25V Continuous |
| Operating Temperature                                    | -40 to 85°C    |
| Storage Temperature                                      | -40 to 85°     |

**Power Dissipation (T<sub>amb</sub>= 25°C)**

|       |       |
|-------|-------|
| SO8   | 500mW |
| MSOP8 | 500mW |

**ELECTRICAL CHARACTERISTICS TEST CONDITIONS (Unless otherwise stated):**
**T<sub>amb</sub>= 25°C, V<sub>CC</sub>=5V, I<sub>D</sub>=10mA (R<sub>CAL1</sub>=33kΩ)**

| SYMBOL             | PARAMETER   | CONDITIONS  | LIMITS               |                      |                 | UNITS |
|--------------------|---|---|----------------------|----------------------|-----------------|-------|
|                    |   |   | Min                  | Typ                  | Max             |       |
| V <sub>CC</sub>    | Supply Voltage  |   | 5                    |                      | 12              | V     |
| I <sub>CC</sub>    | Supply Current  | All inputs and outputs open circuit<br>I <sub>VERT1</sub> = I <sub>VERT2</sub> = 10mA, V <sub>POL1</sub> = V <sub>POL2</sub> = 14V<br>I <sub>HOR1</sub> = I <sub>HOR2</sub> = 10mA, V <sub>POL1</sub> = V <sub>POL2</sub> = 15.0V |                      |                      | 10              | mA    |
| I <sub>POL</sub>   | V <sub>POL1</sub> and V <sub>POL2</sub> Inputs<br>Current | V <sub>POL1</sub> = V <sub>POL2</sub> = 25V (Note 4)  | 10                   | 20                   | 40              | μA    |
| V <sub>TPOL</sub>  | Threshold Voltage   | (Note 1) (Note 4)   | 14.0                 | 14.5                 | 15.0            |       |
| T <sub>SPOL</sub>  | Switching Speed   |   |                      |                      | 100             | μs    |
| V <sub>VHIGH</sub> | Vert 1/2 Outputs<br>Voltage High                          | I <sub>VERT1</sub> =I <sub>VERT2</sub> =10mA,<br>V <sub>POL1</sub> = V <sub>POL2</sub> = 14V  | V <sub>CC</sub> -1.0 | V <sub>CC</sub> -0.8 | V <sub>CC</sub> | V     |
| V <sub>VHIGH</sub> | Voltage High  | I <sub>VERT1</sub> =I <sub>VERT2</sub> =15mA,<br>V <sub>POL1</sub> = V <sub>POL2</sub> = 14V  | V <sub>CC</sub> -1.2 | V <sub>CC</sub> -0.9 | V <sub>CC</sub> | V     |
| V <sub>VHIGH</sub> | Voltage High  | I <sub>VERT1</sub> =I <sub>VERT2</sub> =10μA,<br>V <sub>POL1</sub> = V <sub>POL2</sub> = 14V  | V <sub>CC</sub> -0.2 | V <sub>CC</sub> -0.1 | V <sub>CC</sub> | V     |
| V <sub>VLOW</sub>  | Voltage Low   | I <sub>VERT1</sub> =I <sub>VERT2</sub> =-10mA,<br>V <sub>POL1</sub> = V <sub>POL2</sub> = 15.0V   | 0                    | 0.25                 | 0.5             | V     |
| V <sub>VHIGH</sub> | Hor 1/2 Outputs<br>Voltage High                           | I <sub>HOR1</sub> =I <sub>HOR2</sub> =10mA,<br>V <sub>POL1</sub> = V <sub>POL2</sub> = 15.0V  | V <sub>CC</sub> -1.0 | V <sub>CC</sub> -0.8 | V <sub>CC</sub> | V     |
| V <sub>VHIGH</sub> | Voltage High  | I <sub>HOR1</sub> =I <sub>HOR2</sub> =15mA,<br>V <sub>POL1</sub> = V <sub>POL2</sub> = 15.0V  | V <sub>CC</sub> -1.2 | V <sub>CC</sub> -0.9 | V <sub>CC</sub> | V     |
| V <sub>VHIGH</sub> | Voltage High  | I <sub>HOR1</sub> =I <sub>HOR2</sub> =10μA,<br>V <sub>POL1</sub> = V <sub>POL2</sub> = 15.0V  | V <sub>CC</sub> -0.2 | V <sub>CC</sub> -0.1 | V <sub>CC</sub> | V     |
| V <sub>VLOW</sub>  | Voltage Low   | I <sub>HOR1</sub> =I <sub>HOR2</sub> =-10mA,<br>V <sub>POL1</sub> = V <sub>POL2</sub> = 14V   | 0                    | 0.25                 | 0.5             | V     |

ZLNB100

**Note:-**

- 1)  $V_{POL1}$  and  $V_{POL2}$  switching thresholds apply over the whole operating temperature range specified above.
- 2) Inputs  $V_{POL1}$  and  $V_{POL2}$  are designed to be wired to the power input of an LNB via high value (10k) resistors. Input  $V_{POL1}$  controls outputs Vert1 and Hor1. Input  $V_{POL2}$  controls outputs Vert2 and Hor2. With either input voltage set at or below 14V, the corresponding Vert pin will be high and Hor pin low. With either input voltage at or above 15.0V, the corresponding Vert pin will be low and Hor pin high. Any input or output not required may be left open-circuit.
- 3) All outputs are designed to be compatible with TTL, CMOS, pin diode and IF Amp loads.
- 4) Applied via 10k resistors

The following block diagram shows a typical block diagram twin LNB design. The ZLNB100 provides the two polarity switches required to decode the two independent receiver feeds. Additionally the front end bias requirements of the LNB are provided by the ZNBG4000 or ZNBG6000 offering a very efficient and cost effective solution.

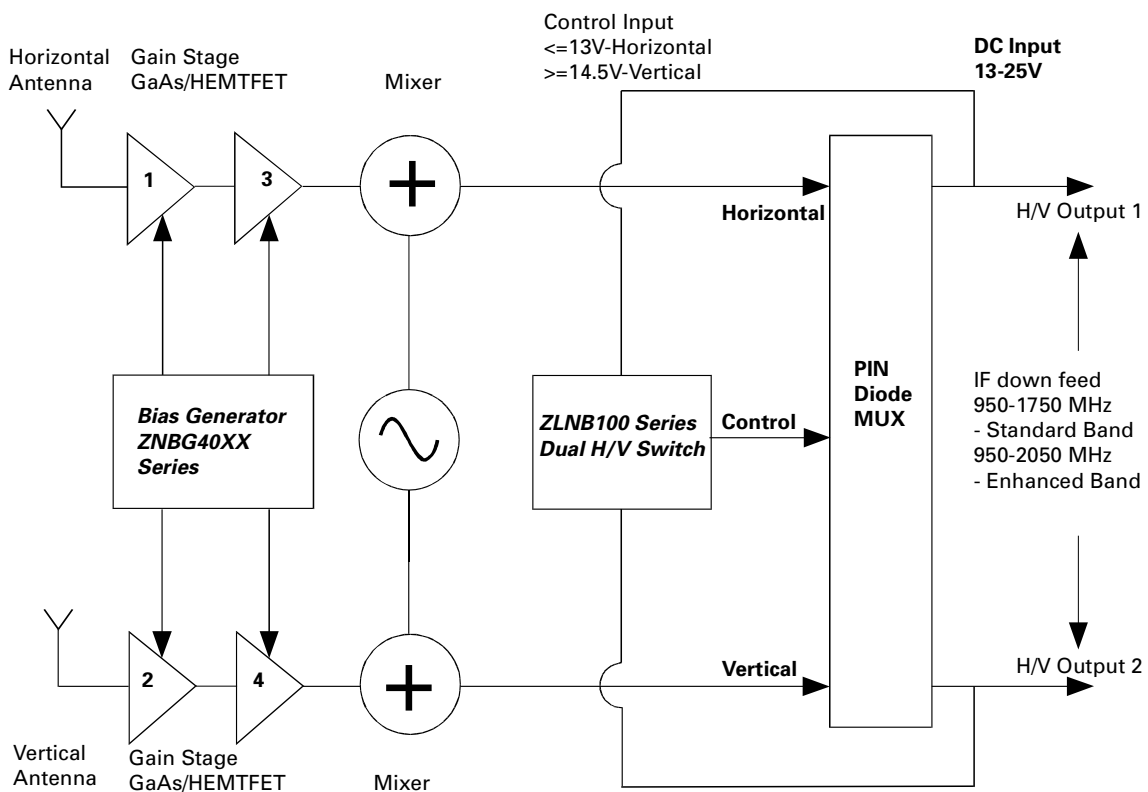

# ZLNB100

## CONNECTION DIAGRAMS

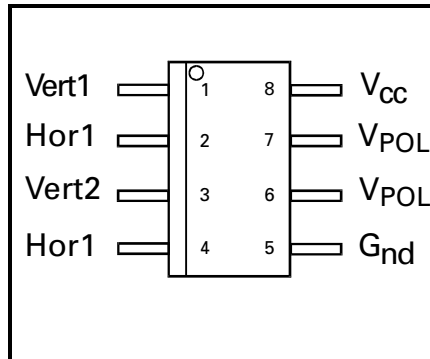

## ORDERING INFORMATION

| Part Number | Package | Part Mark |
|-------------|---------|-----------|
| ZLNB100X    | MSOP8   | ZLNB100   |
| ZLNB100N8   | SO8     | ZLNB100   |

# ZLNB100

## PACKAGE DIMENSIONS

### MSOP8

| DIM            | Millimetres |      | Inches |       |
|----------------|-------------|------|--------|-------|
|                | MIN         | MAX  | MIN    | MAX   |
| A              | 0.91        | 1.11 | 0.036  | 0.044 |
| A1             | 0.10        | 0.20 | 0.004  | 0.008 |
| B              | 0.25        | 0.36 | 0.010  | 0.014 |
| C              | 0.13        | 0.18 | 0.005  | 0.007 |
| D              | 2.95        | 3.05 | 0.116  | 0.120 |
| e              | 0.65        | NOM  | 0.0256 | NOM   |
| e1             | 0.33        | NOM  | 0.0128 | NOM   |
| E              | 2.95        | 3.05 | 0.116  | 0.120 |
| H              | 4.78        | 5.03 | 0.188  | 0.198 |
| L              | 0.41        | 0.66 | 0.016  | 0.026 |
| $\theta^\circ$ | 0°          | 6°   | 0°     | 6°    |

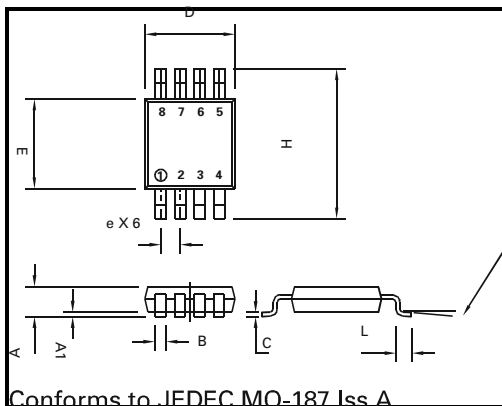

### SO8

| DIM | Millimetres |      | Inches   |       |
|-----|-------------|------|----------|-------|
|     | Min         | Max  | Min      | Max   |
| A   | 4.80        | 4.98 | 0.189    | 0.196 |
| B   | 1.27 BSC    |      | 0.05 BSC |       |
| C   | 0.53 REF    |      | 0.02 REF |       |
| D   | 0.36        | 0.46 | 0.014    | 0.018 |
| E   | 3.81        | 3.99 | 0.15     | 0.157 |
| F   | 1.35        | 1.75 | 0.05     | 0.07  |
| G   | 0.10        | 0.25 | 0.004    | 0.010 |
| J   | 5.80        | 6.20 | 0.23     | 0.24  |
| K   | 0°          | 8°   | 0°       | 8°    |
| L   | 0.41        | 1.27 | 0.016    | 0.050 |

