

## Excellent Integrated System Limited

Stocking Distributor

Click to view price, real time Inventory, Delivery & Lifecycle Information:

[Diodes Incorporated](#)  
[ZSM530CL](#)

For any questions, you can email us directly:

[sales@integrated-circuit.com](mailto:sales@integrated-circuit.com)

## SUPPLY VOLTAGE MONITOR

ISSUE 2 – JANUARY 2003

# ZSM530

### DEVICE DESCRIPTION

The ZSM530 is a three terminal under voltage monitor circuit for use in microprocessor systems. The threshold voltage of the device has been set to 4.3 volts making it ideal for 5 volt circuits.

Included in the device is a precise voltage reference and a comparator with built in hysteresis to prevent erratic operation. The ZSM530 features an open collector output capable of sinking at least 10mA which only requires a single external resistor to interface to following circuits.

Operation of the device is guaranteed from one volt upwards, from this level to the device threshold voltage the output is held low providing a power on reset function. Should the supply voltage, once established, at any time drop below the threshold level then the output again will pull low.

The device is available in a TO92 package for through hole applications as well as SOT223 for surface mount requirements.

### FEATURES

- SOT223 and TO92 packages
- Power on reset generator
- Automatic reset generation
- Low standby current
- Guaranteed operation from 1 volt
- Wide supply voltage range
- Internal clamp diode to discharge delay capacitor
- 4.3 volt threshold for 5 volt logic
- 20mV hysteresis prevents erratic operation

### APPLICATIONS

- Microprocessor systems
- Computers
- Computer peripherals
- Instrumentation
- Automotive
- Battery powered equipment

### SCHEMATIC DIAGRAM

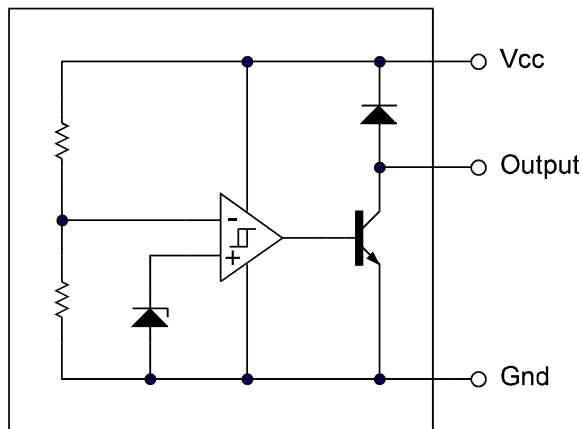

# ZSM530

## ABSOLUTE MAXIMUM RATING

Input Supply Voltage	-1 to 10V	<b>Power Dissipation</b>	
Offstate Output Voltage	10V	TO92	780mW
Onstate Output		SOT223	2W(Note 2)
Sink Current(Note 1)	Internally limited		
Clamp Diode			
Forward Current(Note 1)	100mA		
Operating Junction Temperature	150°C		
Operating Temperature	-40 to 85°C		
Storage Temperature	-55 to 150°C		

## TEST CONDITIONS

(T<sub>amb</sub>=25°C for typical values, T<sub>amb</sub>=-40 to 85°C for min/max values (Note3))

## COMPARATOR

PARAMETER	SYMBOL	MIN	TYP.	MAX.	UNITS
Threshold Voltage High state output (V <sub>cc</sub> increasing)	V <sub>IH</sub>	4.2	4.31	4.4	V
Threshold Voltage Low state output (V <sub>cc</sub> decreasing)	V <sub>IL</sub>	4.2	4.29	4.4	V
Hysteresis	V <sub>H</sub>	0.01	0.02	0.05	V

## OUTPUT

Output sink saturation: (V <sub>cc</sub> =3.8V, I <sub>sink</sub> =8.0mA)	V <sub>OL</sub>		0.46	1.0	V
(V <sub>cc</sub> =3.8V, I <sub>sink</sub> =2.0mA)			0.15	0.4	V
(V <sub>cc</sub> =1.0V, I <sub>sink</sub> =0.1mA)				0.25	V
Onstate output sink current (V <sub>cc</sub> , Output=3.8V)	I <sub>sink</sub>	10	27	60	mA
Offstate output leakage current (V <sub>cc</sub> , Output=5V)	I <sub>oh</sub>		0.02	0.5	μA
Clamp diode forward voltage (I <sub>f</sub> =10mA)	V <sub>f</sub>	0.6	1.2	1.5	V
Propagation delay (V <sub>in</sub> 5V to 3.8V, R <sub>I</sub> =10k, T <sub>amb</sub> =25°C)	T <sub>d</sub>		2		μs

## TOTAL DEVICE

Operating input voltage range	V <sub>cc</sub>	1.0 to 6.5			V
Quiescent input current (V <sub>cc</sub> =5V)	I <sub>q</sub>		175	260	μA

### Note:

1. Maximum package power dissipation must be observed.
2. Maximum power dissipation for the SOT223 package is calculated assuming that the device is mounted on a PCB measuring 2 inches square.
3. Low duty cycle pulse techniques are used during test to maintain junction temperatures as close to ambient as possible.

**ZSM530**

**TYPICAL CHARACTERISTICS**

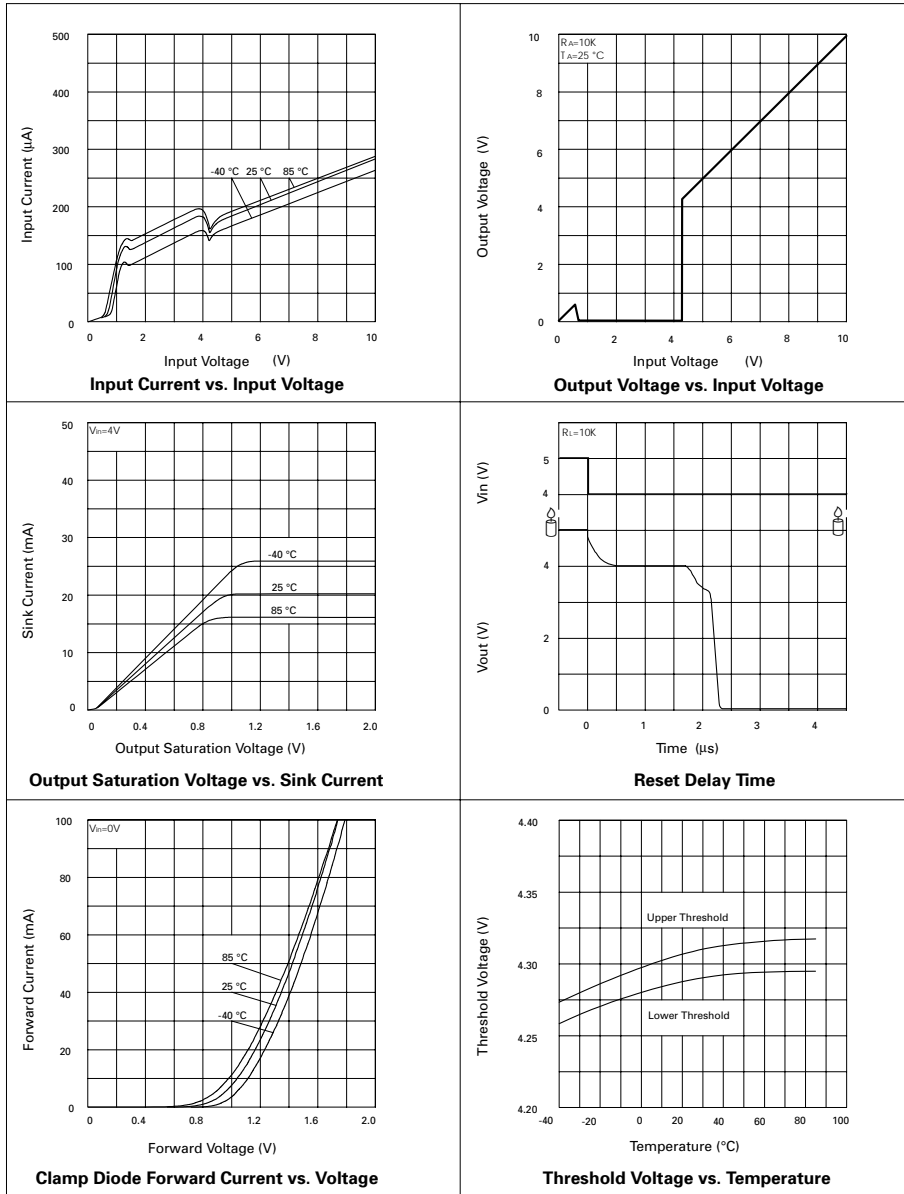

**ZSM530**

**TIMING DIAGRAM**

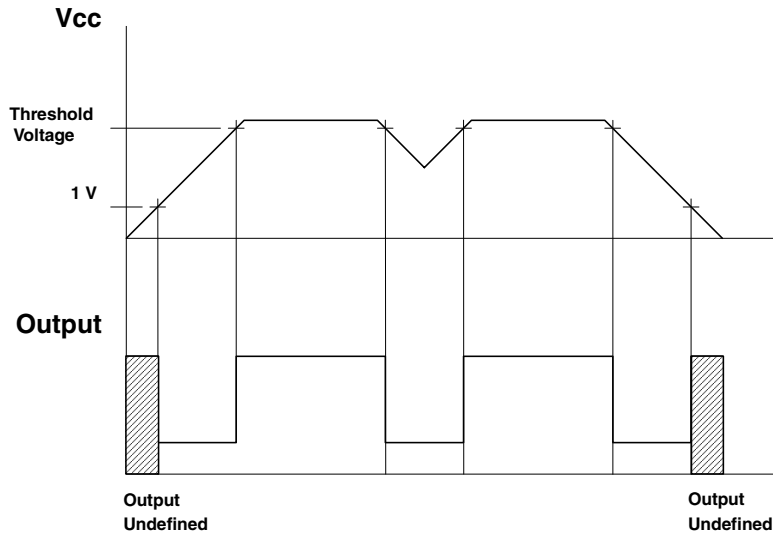

**APPLICATION CIRCUIT**

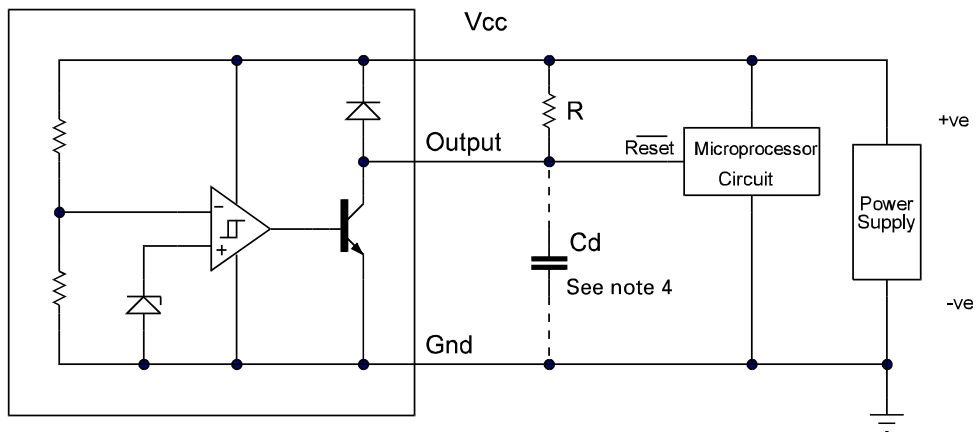

Note 4: A time delayed reset can be accomplished with the additional Cd.

$$T_{DY} = RCd \ln \left( \frac{1}{1 - \frac{V_{TH(mpu)}}{V_{in}}} \right)$$

$T_{DY}$  =Time (Seconds)  
 $V_{TH}$  =Microprocessor Reset Threshold  
 $V_{in}$  =Power Supply Voltage

# ZSM530

## CONNECTION DIAGRAMS

**SOT223** Package Suffix - G

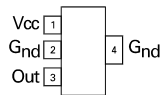

*Top View –  
 Pin 4 floating or connected to pin 2*

**TO92** Package Suffix - C

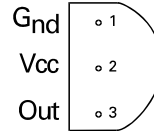

*Bottom View*

## ORDERING INFORMATION

Part Number	Package	Part Mark
ZSM530G	SOT223	ZSM530
ZSM530C	TO92	ZSM530