

Excellent Integrated System Limited

Stocking Distributor

Click to view price, real time Inventory, Delivery & Lifecycle Information:

[Amphenol RF](#)
[122332](#)

For any questions, you can email us directly:

sales@integrated-circuit.com

REV.	DATE	DESCRIPTION
A	01/10/04	UPDATE DRAWING FORMAT

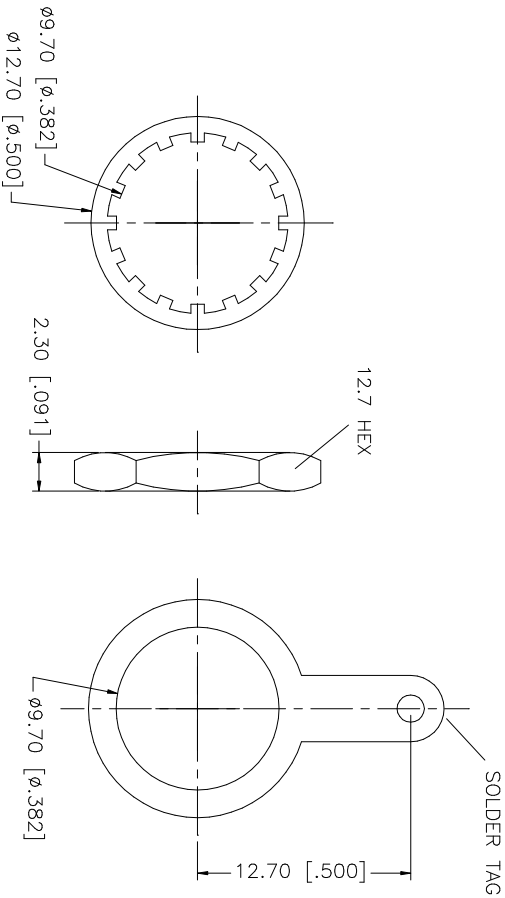
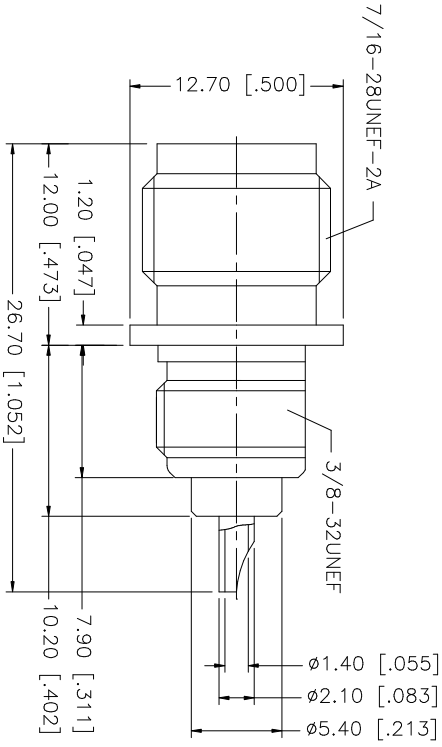
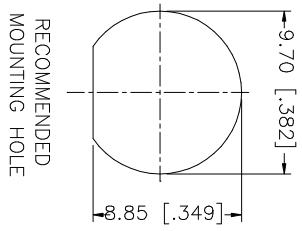

NOTE:
1. MAX. PANEL THICKNESS = 3.2mm

QTY	FINISH	MATERIAL	DESCRIPTION
1	NICKEL	BRASS	BODY
1	NATURAL	DELIRIN	INSULATOR
1	GOLD	PHOS. BRONZE	CONTACT PIN
1	NICKEL	BRASS	LOCK WASHER
1	NICKEL	BRASS	HEX NUT
1	NICKEL	BRASS	SOLDER TAB

APPROVALS	DATE
G.R.S.	01/10/04

UNLESS OTHERWISE SPECIFIED DIMENSIONS ARE IN MILLIMETERS DIMENSIONS IN INCHES ARE FOR REFERENCE ONLY.
UNLESS OTHERWISE SPECIFIED TOLERANCES FOR MILLIMETERS ARE: 0.5 - 8mm ± 0.20mm 8 - 30mm ± 0.40mm 30 - 120mm ± 0.50mm

UNLESS OTHERWISE SPECIFIED TOLERANCES FOR INCHES ARE:
.020 - .315 = ± 0.007" .315 - 1.180 = ± 0.015" 1.180 - 4.724 = ± 0.020"

CAD FILE
C:/122/122332.DWG

PART NO.	DWG. NO.	REV.	SIZE	SCALE
122332	122332.DWG	A	A	NA

PART DESCRIPTION
TNC BULKHEAD RECEPT. JACK

Amphenol Connex