

## **Excellent Integrated System Limited**

Stocking Distributor

Click to view price, real time Inventory, Delivery & Lifecycle Information:

[Advanced Photonix, Inc.](#)  
[SD100-11-21-221](#)

For any questions, you can email us directly:

[sales@integrated-circuit.com](mailto:sales@integrated-circuit.com)

**Red Enhanced Silicon Photodiode**  
**SD 100-11-21-221**

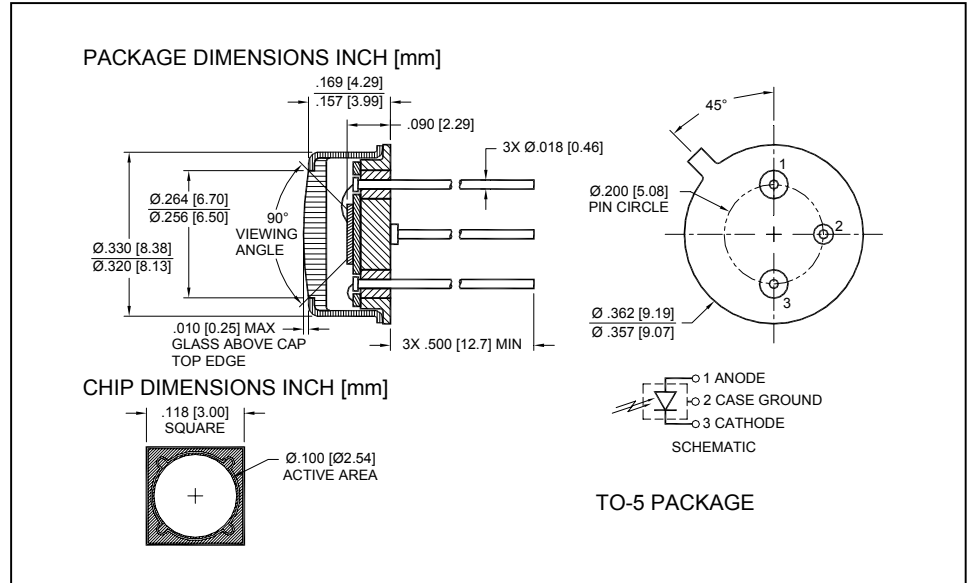

**FEATURES**

- Low noise
- Red enhanced
- High shunt resistance
- High response

**DESCRIPTION**

The **SD 100-11-21-221** is a general purpose silicon PIN photodiode, red enhanced, packaged in a leaded hermetic TO-5 metal package.

**APPLICATIONS**

- Instrumentation
- Industrial
- Medical

**ABSOLUTE MAXIMUM RATING** (TA)= 23°C UNLESS OTHERWISE NOTED

SYMBOL	PARAMETER	MIN	MAX	UNITS
V <sub>BR</sub>	Reverse Voltage		75	V
T <sub>STG</sub>	Storage Temperature	-55	+150	°C
T <sub>O</sub>	Operating Temperature	-40	+125	°C
T <sub>S</sub>	Soldering Temperature*		+240	°C

\* 1/16 inch from case for 3 seconds max.

**SPECTRAL RESPONSE**

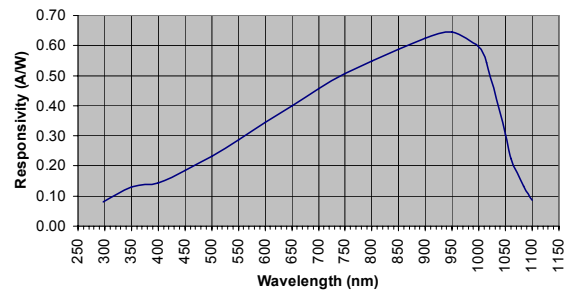

**ELECTRO-OPTICAL CHARACTERISTICS RATING** (TA)= 23°C UNLESS OTHERWISE NOTED

SYMBOL	CHARACTERISTIC	TEST CONDITIONS	MIN	TYP	MAX	UNITS
I <sub>D</sub>	Dark Current	V <sub>R</sub> = 5V		1.6	6.4	nA
R <sub>SH</sub>	Shunt Resistance	V <sub>R</sub> = 10 mV	300			MΩ
C <sub>J</sub>	Junction Capacitance	V <sub>R</sub> = 0V, f = 1 MHz		87		pF
		V <sub>R</sub> = 10V, f = 1 MHz		18		
λ range	Spectral Application Range	Spot Scan	350		1100	nm
R	Responsivity	λ = 633nm, V <sub>R</sub> = 0 V	0.32	0.36		A/W
		λ = 900nm, V <sub>R</sub> = 0 V	0.50	0.55		
V <sub>BR</sub>	Breakdown Voltage	I = 10 μA		50		V
NEP	Noise Equivalent Power	V <sub>R</sub> = 5V @ λ = 950nm		4.0X10 <sup>-14</sup>		W/√Hz
τ <sub>r</sub>	Response Time**	RL = 50 Ω, V <sub>R</sub> = 0 V		190		nS
		RL = 50 Ω, V <sub>R</sub> = 10 V		13		

\*\*Response time of 10% to 90% is specified at 660nm wavelength light.

Information in this technical datasheet is believed to be correct and reliable. However, no responsibility is assumed for possible inaccuracies or omission. Specifications are subject to change without notice.