

## Excellent Integrated System Limited

Stocking Distributor

Click to view price, real time Inventory, Delivery & Lifecycle Information:

[STMicroelectronics](#)  
[74LCX257MTR](#)

For any questions, you can email us directly:

[sales@integrated-circuit.com](mailto:sales@integrated-circuit.com)



# 74LCX257

## LOW VOLTAGE CMOS QUAD 2 CHANNEL MULTIPLEXER WITH 5V TOLERANT INPUTS AND OUTPUTS (3-STATE)

- 5V TOLERANT INPUTS AND OUTPUTS
- HIGH SPEED:  
 $t_{PD} = 6.0 \text{ ns (MAX.) at } V_{CC} = 3V$
- POWER DOWN PROTECTION ON INPUTS AND OUTPUTS
- SYMMETRICAL OUTPUT IMPEDANCE:  
 $|I_{OH}| = I_{OL} = 24\text{mA (MIN) at } V_{CC} = 3V$
- PCI BUS LEVELS GUARANTEED AT 24 mA
- BALANCED PROPAGATION DELAYS:  
 $t_{PLH} \cong t_{PHL}$
- OPERATING VOLTAGE RANGE:  
 $V_{CC(OPR)} = 2.0V \text{ to } 3.6V \text{ (1.5V Data Retention)}$
- PIN AND FUNCTION COMPATIBLE WITH 74 SERIES 257
- LATCH-UP PERFORMANCE EXCEEDS 500mA (JESD 17)
- ESD PERFORMANCE:  
 HBM > 2000V (MIL STD 883 method 3015);  
 MM > 200V

### DESCRIPTION

The 74LCX257 is a low voltage CMOS QUAD 2 CHANNEL MULTIPLEXER (3-STATE) fabricated with sub-micron silicon gate and double-layer metal wiring C<sup>2</sup>MOS technology. It is ideal for low power and high speed 3.3V applications; it can be interfaced to 5V signal environment for both inputs and outputs.

Figure 1: Pin Connection And IEC Logic Symbols

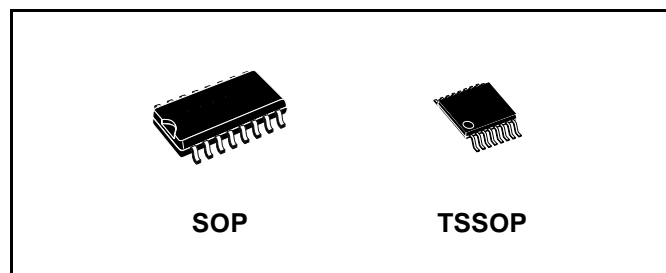
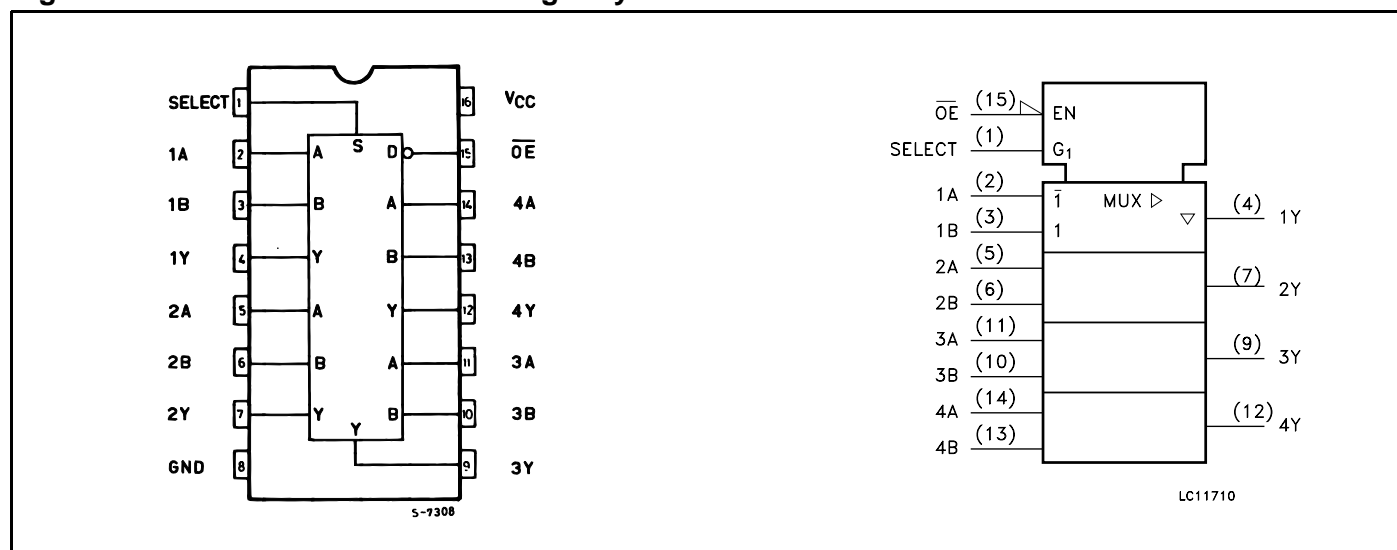

Table 1: Order Codes

PACKAGE	T & R
SOP	74LCX257MTR
TSSOP	74LCX257TTR

It is composed of four independent 2 channel multiplexers with common SELECT and ENABLE ( $\overline{OE}$ ) INPUT. The 74LCX257 is a non-inverting multiplexer. When the ENABLE INPUT is held "High", all outputs become in high impedance state. If SELECT INPUT is held "Low", "A" data is selected, when SELECT INPUT is "High", "B" data is chosen.

It has same speed performance at 3.3V than 5V AC/ACT family, combined with a lower power consumption.

All inputs and outputs are equipped with protection circuits against static discharge, giving them 2KV ESD immunity and transient excess voltage.

**74LCX257**

**Figure 2: Input And Output Equivalent Circuit**

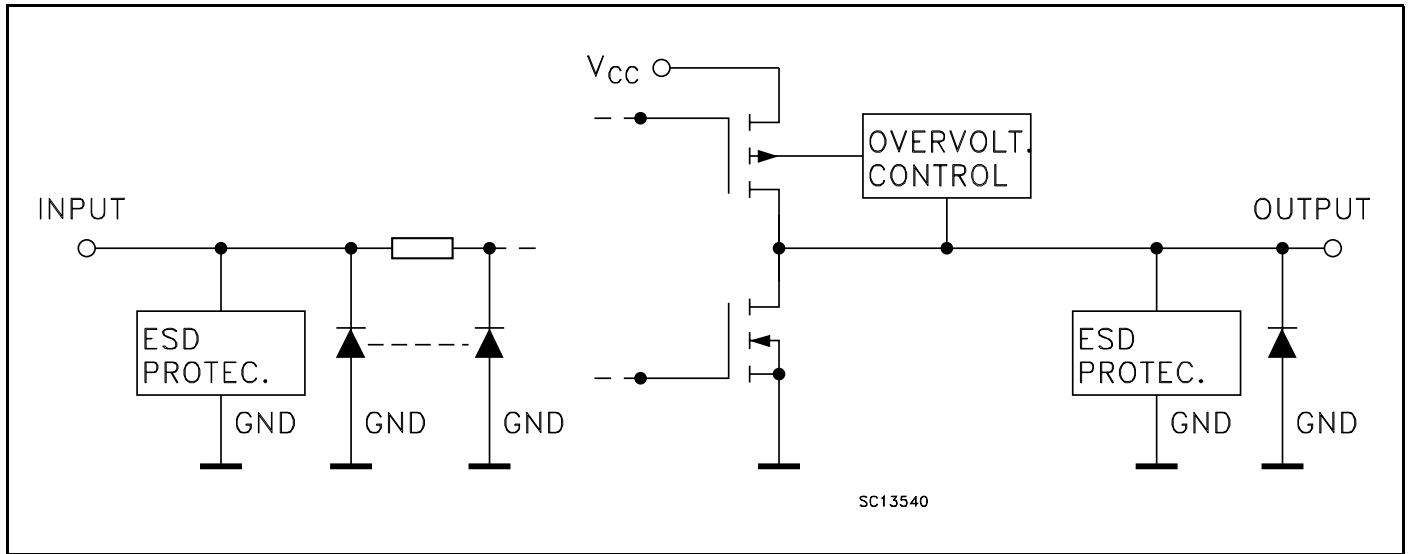

**Table 2: Pin Description**

PIN N°	SYMBOL	NAME AND FUNCTION
1	SELECT	Common Data Select Inputs
2, 5, 11, 14	1A to 4A	Data Inputs From Source A
3, 6, 10, 13	1B to 4B	Data Inputs From Source B
4, 7, 9, 12	1Y to 4Y	3 State Multiplexer Outputs
15	$\overline{OE}$	3 State Output Enable Inputs (Active LOW)
8	GND	Ground (0V)
16	V <sub>CC</sub>	Positive Supply Voltage

**Table 3: Truth Table**

INPUTS				OUTPUT
$\overline{OE}$	SELECT	A	B	Y
H	X	X	X	Z
L	L	L	X	L
L	L	H	X	H
L	H	X	L	L
L	H	X	H	H

X : Don't Care  
Z : High Impedance

Figure 3: Logic Diagram

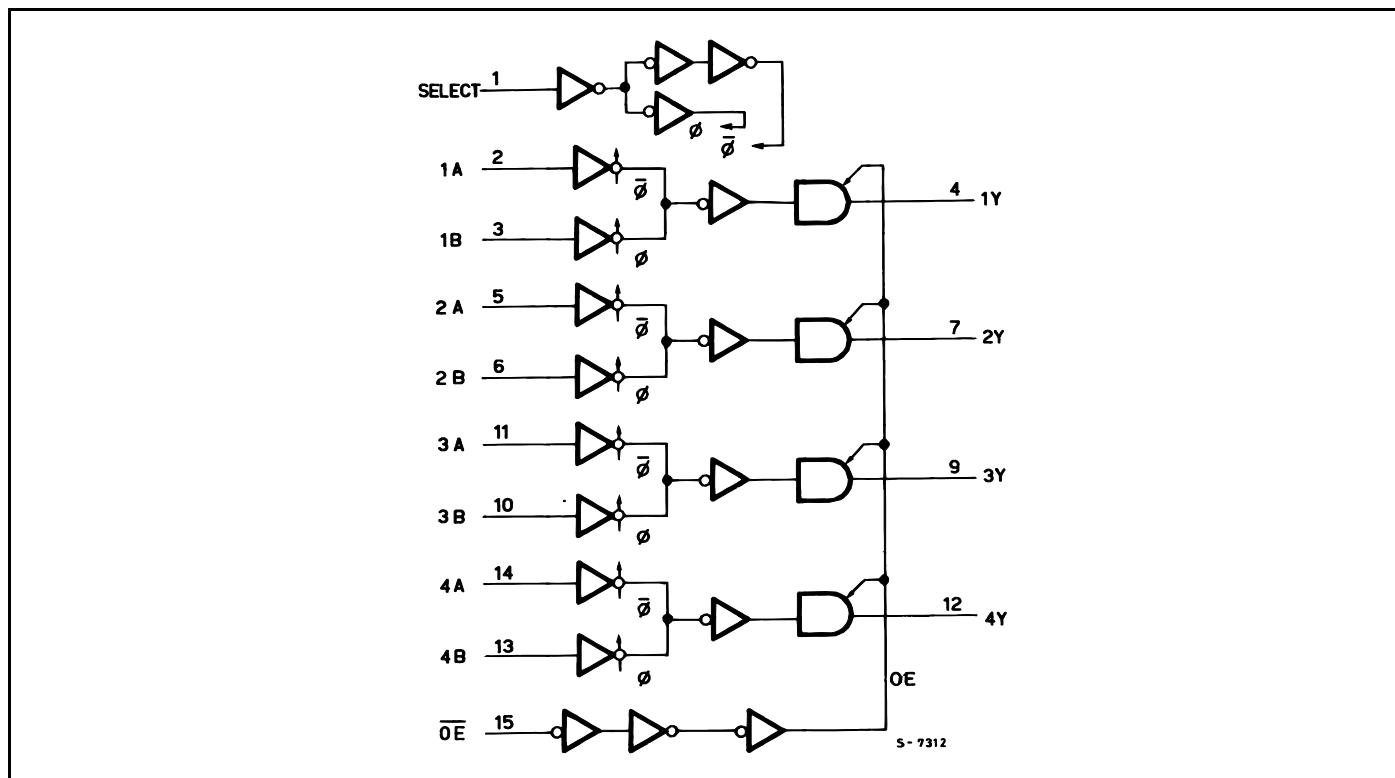

This logic diagram has not be used to estimate propagation delays

Table 4: Absolute Maximum Ratings

Symbol	Parameter	Value	Unit
$V_{CC}$	Supply Voltage	-0.5 to +7.0	V
$V_I$	DC Input Voltage	-0.5 to +7.0	V
$V_O$	DC Output Voltage (OFF State)	-0.5 to +7.0	V
$V_O$	DC Output Voltage (High or Low State) (note 1)	-0.5 to $V_{CC} + 0.5$	V
$I_{IK}$	DC Input Diode Current	- 50	mA
$I_{OK}$	DC Output Diode Current (note 2)	- 50	mA
$I_O$	DC Output Current	$\pm 50$	mA
$I_{CC}$	DC Supply Current per Supply Pin	$\pm 100$	mA
$I_{GND}$	DC Ground Current per Supply Pin	$\pm 100$	mA
$T_{stg}$	Storage Temperature	-65 to +150	$^{\circ}C$
$T_L$	Lead Temperature (10 sec)	300	$^{\circ}C$

Absolute Maximum Ratings are those values beyond which damage to the device may occur. Functional operation under these conditions is not implied

- 1)  $I_O$  absolute maximum rating must be observed
- 2)  $V_O < GND$

## 74LCX257

**Table 5: Recommended Operating Conditions**

Symbol	Parameter	Value	Unit
$V_{CC}$	Supply Voltage (note 1)	2.0 to 3.6	V
$V_I$	Input Voltage	0 to 5.5	V
$V_O$	Output Voltage (OFF State)	0 to 5.5	V
$V_O$	Output Voltage (High or Low State)	0 to $V_{CC}$	V
$I_{OH}, I_{OL}$	High or Low Level Output Current ( $V_{CC} = 3.0$ to $3.6V$ )	$\pm 24$	mA
$I_{OH}, I_{OL}$	High or Low Level Output Current ( $V_{CC} = 2.7V$ )	$\pm 12$	mA
$T_{op}$	Operating Temperature	-55 to 125	$^{\circ}C$
dt/dv	Input Rise and Fall Time (note 2)	0 to 10	ns/V

1) Truth Table guaranteed: 1.5V to 3.6V

2)  $V_{IN}$  from 0.8V to 2V at  $V_{CC} = 3.0V$

**Table 6: DC Specifications**

Symbol	Parameter	Test Condition		Value				Unit
		$V_{CC}$ (V)		-40 to 85 $^{\circ}C$		-55 to 125 $^{\circ}C$		
				Min.	Max.	Min.	Max.	
$V_{IH}$	High Level Input Voltage	2.7 to 3.6		2.0		2.0		V
$V_{IL}$	Low Level Input Voltage				0.8		0.8	V
$V_{OH}$	High Level Output Voltage	2.7 to 3.6	$I_O = -100 \mu A$	$V_{CC} - 0.2$		$V_{CC} - 0.2$		V
		2.7	$I_O = -12 mA$	2.2		2.2		
		3.0	$I_O = -18 mA$	2.4		2.4		
			$I_O = -24 mA$	2.2		2.2		
$V_{OL}$	Low Level Output Voltage	2.7 to 3.6	$I_O = 100 \mu A$		0.2		0.2	V
		2.7	$I_O = 12 mA$		0.4		0.4	
		3.0	$I_O = 16 mA$		0.4		0.4	
			$I_O = 24 mA$		0.55		0.55	
$I_I$	Input Leakage Current	2.7 to 3.6	$V_I = 0$ to $5.5V$		$\pm 5$		$\pm 5$	$\mu A$
$I_{off}$	Power Off Leakage Current	0	$V_I$ or $V_O = 5.5V$		10		10	$\mu A$
$I_{OZ}$	High Impedance Output Leakage Current	2.7 to 3.6	$V_I = V_{IH}$ or $V_{IL}$ $V_O = 0$ to $V_{CC}$		$\pm 5$		$\pm 5$	$\mu A$
$I_{CC}$	Quiescent Supply Current	2.7 to 3.6	$V_I = V_{CC}$ or GND		10		10	$\mu A$
			$V_I$ or $V_O = 3.6$ to $5.5V$		$\pm 10$		$\pm 10$	
$\Delta I_{CC}$	$I_{CC}$ incr. per Input	2.7 to 3.6	$V_{IH} = V_{CC} - 0.6V$		500		500	$\mu A$

**Table 7: Dynamic Switching Characteristics**

Symbol	Parameter	Test Condition		Value			Unit
		V <sub>CC</sub> (V)		T <sub>A</sub> = 25 °C			
				Min.	Typ.	Max.	
V <sub>OLP</sub> V <sub>OLV</sub>	Dynamic Low Level Quiet Output (note 1)	3.3	C <sub>L</sub> = 50pF V <sub>IL</sub> = 0V, V <sub>IH</sub> = 3.3V		0.8 -0.8		V

1) Number of outputs defined as "n". Measured with "n-1" outputs switching from HIGH to LOW or LOW to HIGH. The remaining output is measured in the LOW state.

**Table 8: AC Electrical Characteristics**

Symbol	Parameter	Test Condition				Value				Unit
		V <sub>CC</sub> (V)	C <sub>L</sub> (pF)	R <sub>L</sub> (Ω)	t <sub>s</sub> = t <sub>r</sub> (ns)	-40 to 85 °C		-55 to 125 °C		
						Min.	Max.	Min.	Max.	
t <sub>PLH</sub> t <sub>PHL</sub>	Propagation Delay Time (A, B to Y)	2.7 3.0 to 3.6	50	500	2.5	1.5 1.5	6.5 6.0	1.5 1.5	6.5 6.0	ns
t <sub>PLH</sub> t <sub>PHL</sub>	Propagation Delay Time (SELECT to Y)	2.7 3.0 to 3.6	50	500	2.5	1.5 1.5	8.5 7.0	1.5 1.5	8.5 7.0	ns
t <sub>PZL</sub> t <sub>PZH</sub>	Output Enable Time	2.7 3.0 to 3.6	50	500	2.5	1.5 1.5	8.5 7.0	1.5 1.5	8.5 7.0	ns
t <sub>PLZ</sub> t <sub>PHZ</sub>	Output Disable Time	2.7 3.0 to 3.6	50	500	2.5	1.5 1.5	6.0 5.5	1.5 1.5	6.0 5.5	ns
t <sub>OSLH</sub> t <sub>OSHL</sub>	Output To Output Skew Time (note1, 2)	3.0 to 3.6	50	500	2.5		1.0		1.0	ns

1) Skew is defined as the absolute value of the difference between the actual propagation delay for any two outputs of the same device switching in the same direction, either HIGH or LOW (t<sub>OSLH</sub> = |t<sub>PLHm</sub> - t<sub>PLHn</sub>|, t<sub>OSHL</sub> = |t<sub>PHLm</sub> - t<sub>PHLn</sub>|)

2) Parameter guaranteed by design

**Table 9: Capacitive Characteristics**

Symbol	Parameter	Test Condition		Value			Unit
		V <sub>CC</sub> (V)		T <sub>A</sub> = 25 °C			
				Min.	Typ.	Max.	
C <sub>IN</sub>	Input Capacitance	3.3	V <sub>IN</sub> = 0 to V <sub>CC</sub>		7		pF
C <sub>OUT</sub>	Output Capacitance	3.3	V <sub>IN</sub> = 0 to V <sub>CC</sub>		8		pF
C <sub>PD</sub>	Power Dissipation Capacitance (note 1)	3.3	f <sub>IN</sub> = 10MHz V <sub>IN</sub> = 0 or V <sub>CC</sub>		25		pF

1) C<sub>PD</sub> is defined as the value of the IC's internal equivalent capacitance which is calculated from the operating current consumption without load. (Refer to Test Circuit). Average operating current can be obtained by the following equation. I<sub>CC(opr)</sub> = C<sub>PD</sub> × V<sub>CC</sub> × f<sub>IN</sub> + I<sub>CC</sub>/4 (per channel)

**74LCX257**

**Figure 4: Test Circuit**

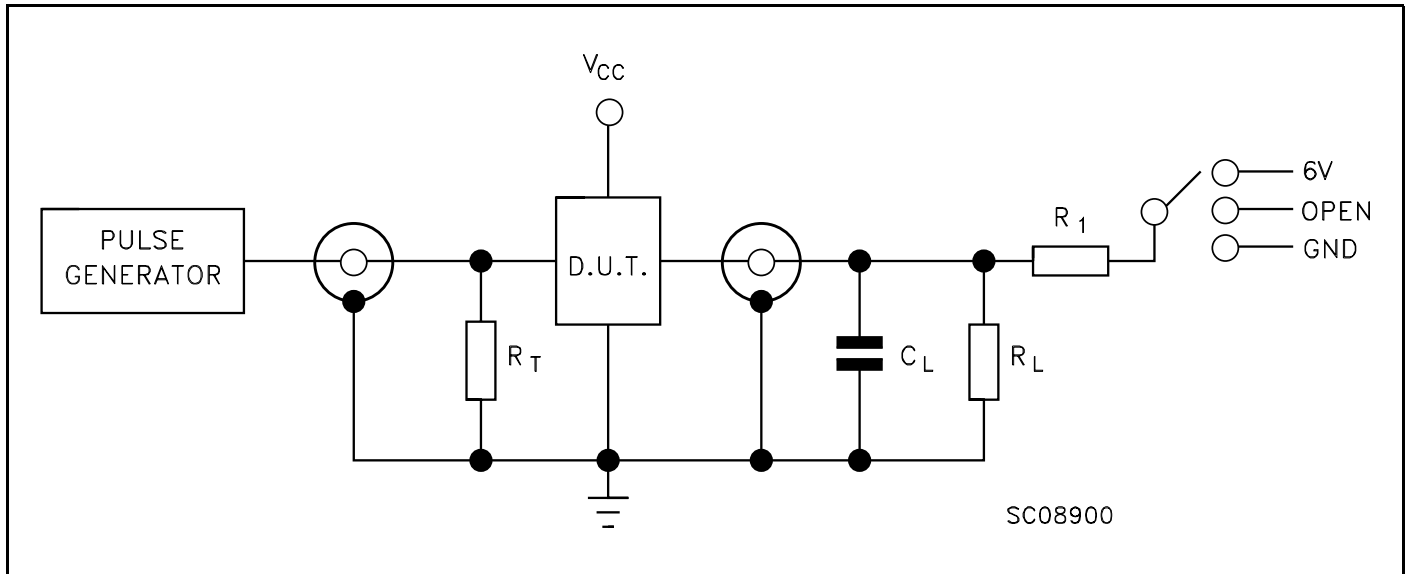

TEST	SWITCH
$t_{PLH}$ , $t_{PHL}$	Open
$t_{PZL}$ , $t_{PLZ}$	6V
$t_{PZH}$ , $t_{PHZ}$	GND

$C_L$  = 50 pF or equivalent (includes jig and probe capacitance)

$R_L$  =  $R_1$  = 500Ω or equivalent

$R_T$  =  $Z_{OUT}$  of pulse generator (typically 50Ω)

**Figure 5: Waveform - Propagation Delays (f=1MHz; 50% duty cycle)**

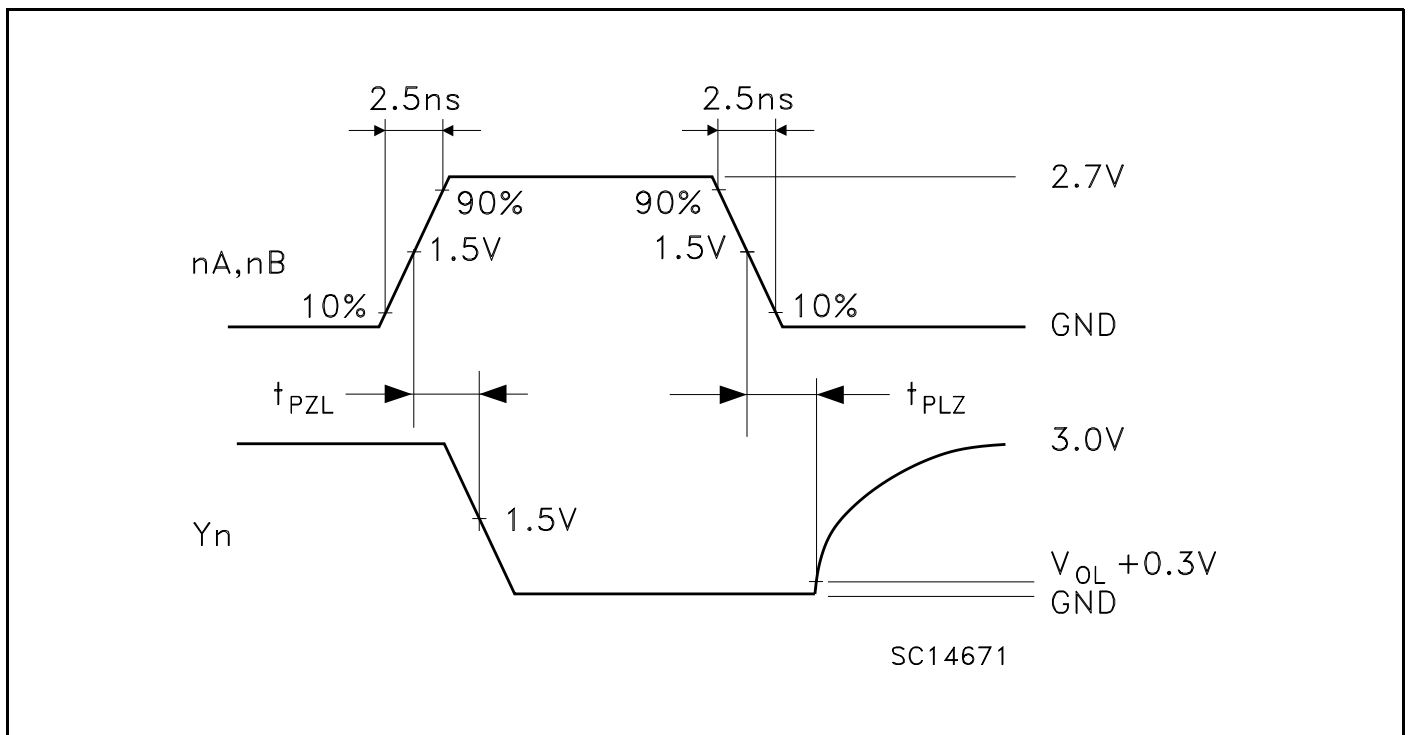

**Figure 6: Waveform - Output Enable And Disable Time (f=1MHz; 50% duty cycle)**

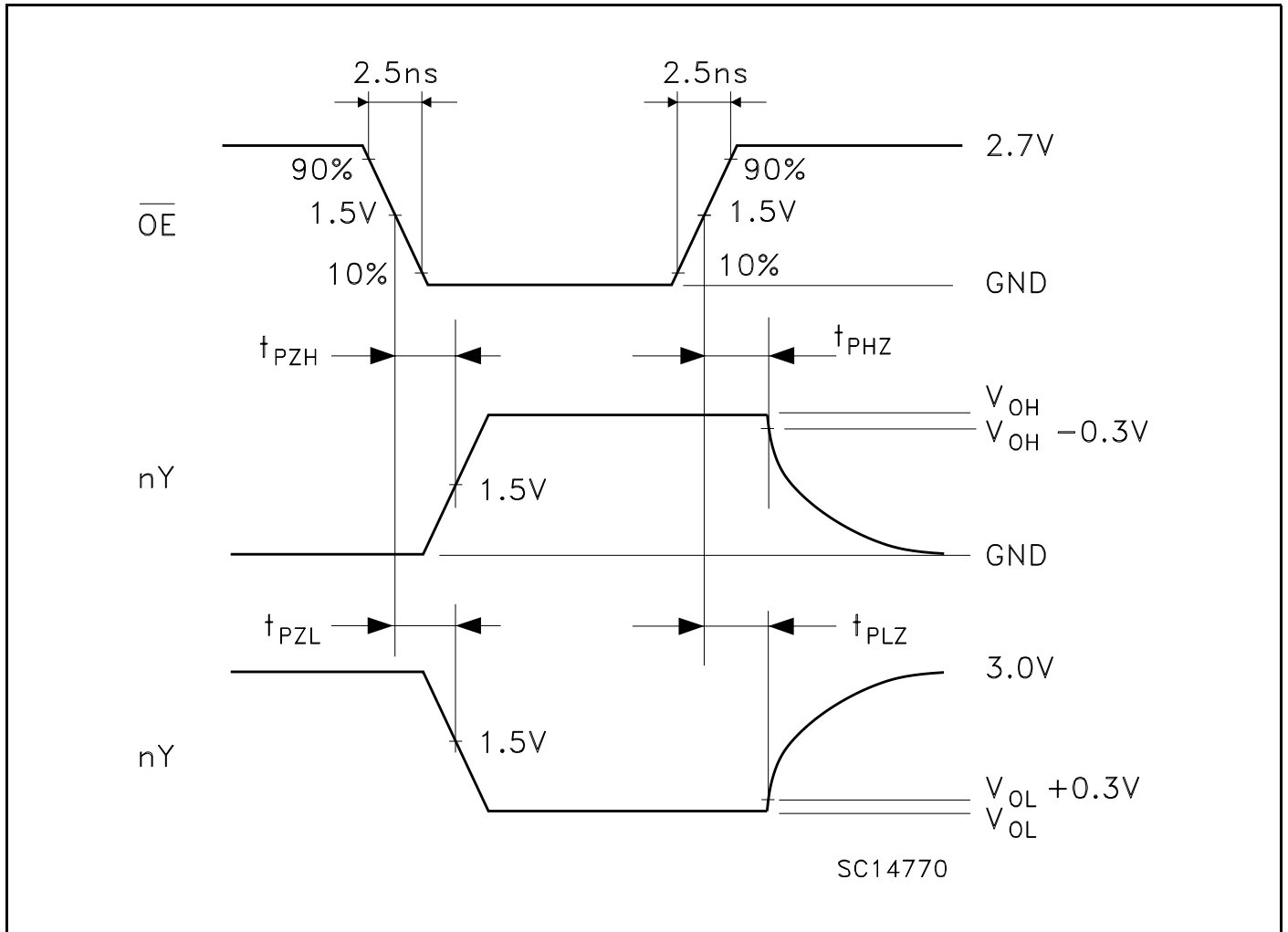



**74LCX257**

**SO-16 MECHANICAL DATA**

DIM.	mm.			inch		
	MIN.	TYP	MAX.	MIN.	TYP.	MAX.
A			1.75			0.068
a1	0.1		0.25	0.004		0.010
a2			1.64			0.063
b	0.35		0.46	0.013		0.018
b1	0.19		0.25	0.007		0.010
C		0.5			0.019	
c1	45° (typ.)					
D	9.8		10	0.385		0.393
E	5.8		6.2	0.228		0.244
e		1.27			0.050	
e3		8.89			0.350	
F	3.8		4.0	0.149		0.157
G	4.6		5.3	0.181		0.208
L	0.5		1.27	0.019		0.050
M			0.62			0.024
S	8° (max.)					

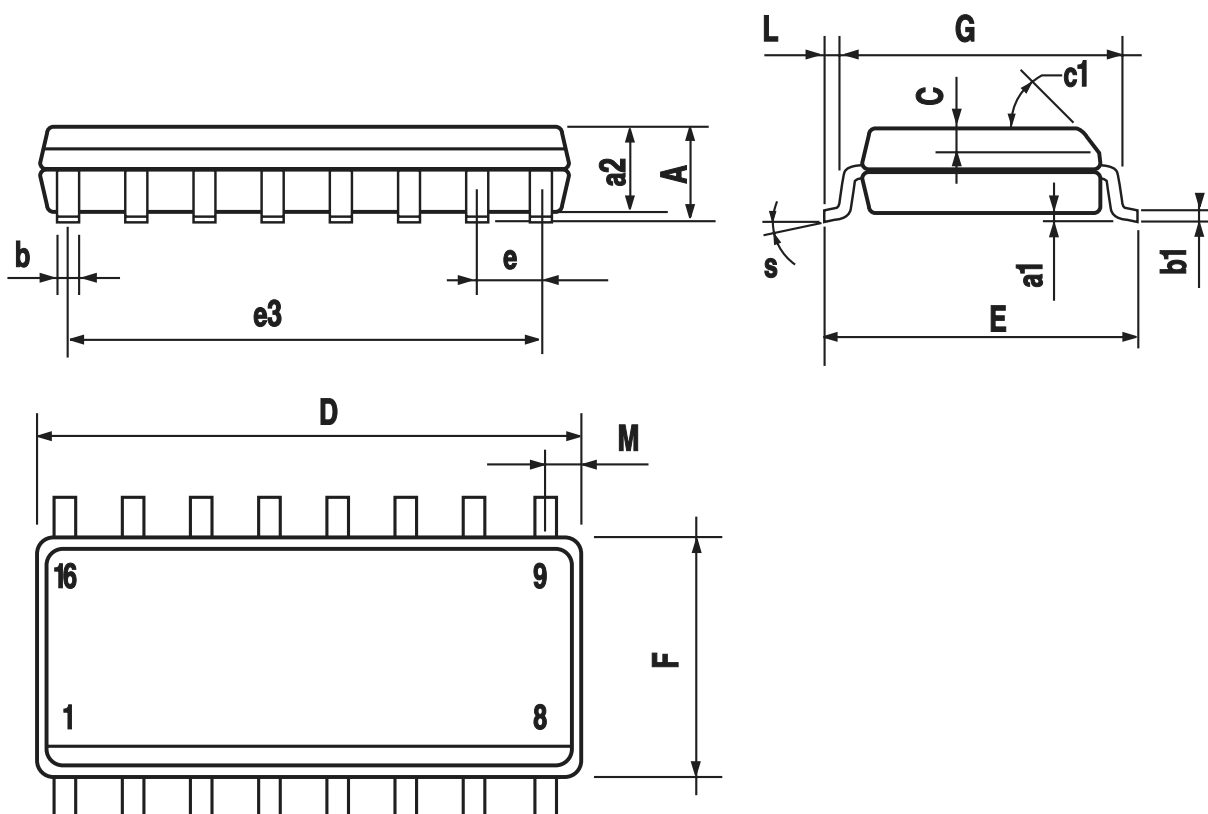

0016020D

**TSSOP16 MECHANICAL DATA**

DIM.	mm.			inch		
	MIN.	TYP	MAX.	MIN.	TYP.	MAX.
A			1.2			0.047
A1	0.05		0.15	0.002	0.004	0.006
A2	0.8	1	1.05	0.031	0.039	0.041
b	0.19		0.30	0.007		0.012
c	0.09		0.20	0.004		0.0079
D	4.9	5	5.1	0.193	0.197	0.201
E	6.2	6.4	6.6	0.244	0.252	0.260
E1	4.3	4.4	4.48	0.169	0.173	0.176
e		0.65 BSC			0.0256 BSC	
K	0°		8°	0°		8°
L	0.45	0.60	0.75	0.018	0.024	0.030

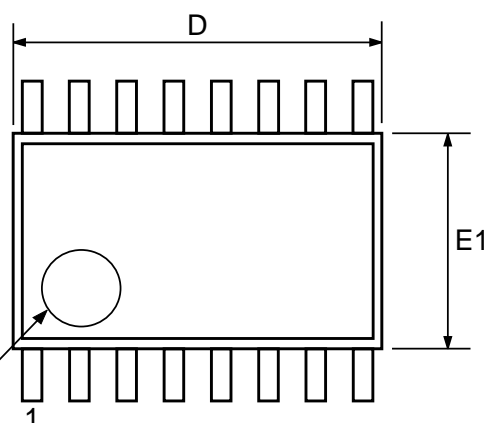
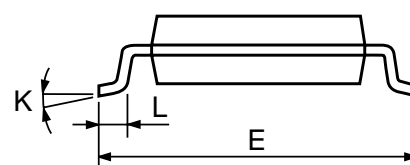
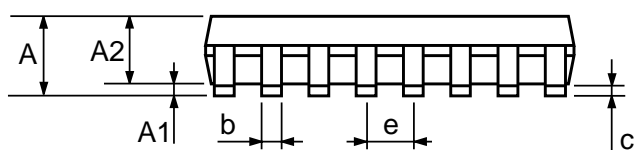

0080338D

**74LCX257**

**Tape & Reel SO-16 MECHANICAL DATA**

DIM.	mm.			inch		
	MIN.	TYP	MAX.	MIN.	TYP.	MAX.
A			330			12.992
C	12.8		13.2	0.504		0.519
D	20.2			0.795		
N	60			2.362		
T			22.4			0.882
Ao	6.45		6.65	0.254		0.262
Bo	10.3		10.5	0.406		0.414
Ko	2.1		2.3	0.082		0.090
Po	3.9		4.1	0.153		0.161
P	7.9		8.1	0.311		0.319

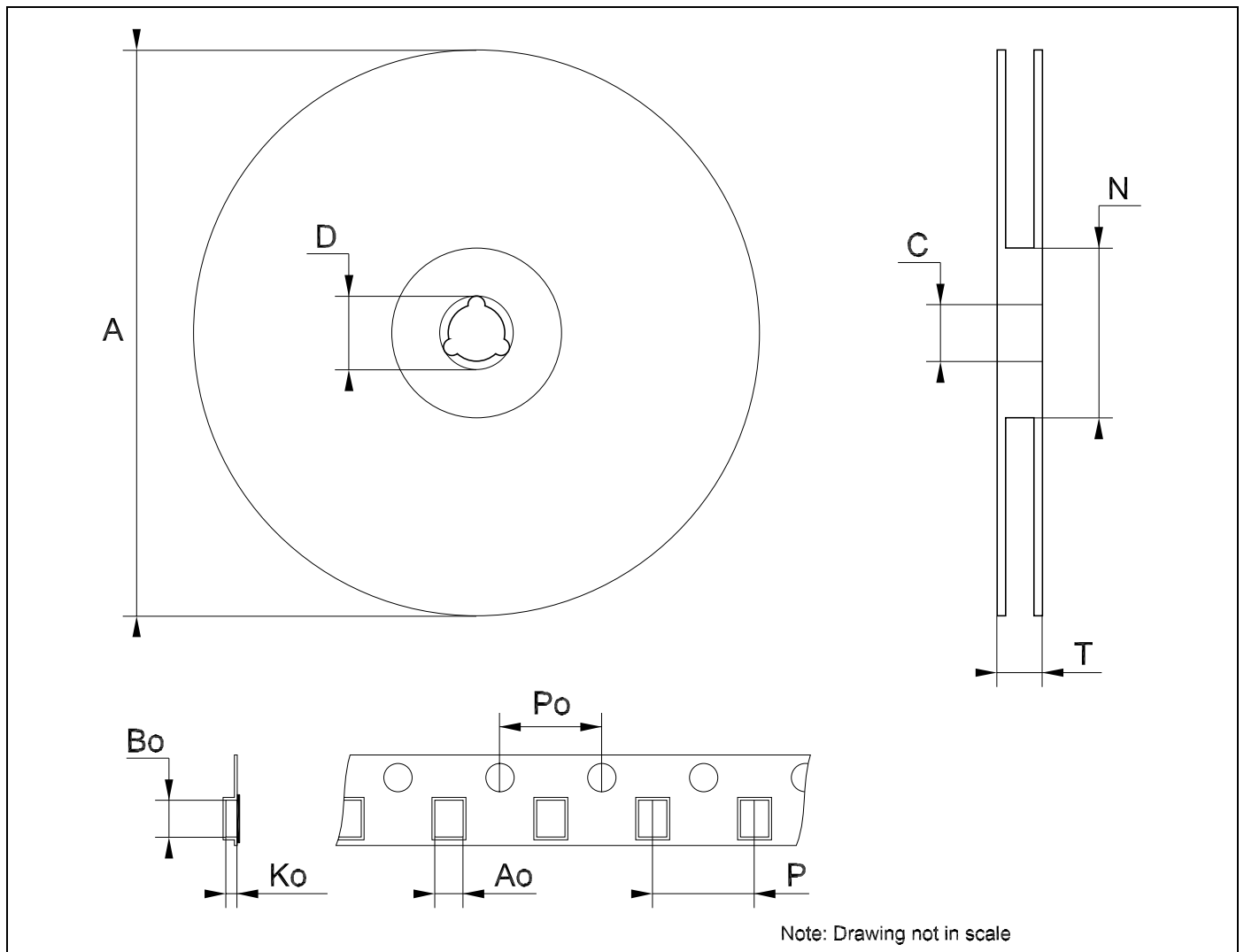

**Tape & Reel TSSOP16 MECHANICAL DATA**

DIM.	mm.			inch		
	MIN.	TYP	MAX.	MIN.	TYP.	MAX.
A			330			12.992
C	12.8		13.2	0.504		0.519
D	20.2			0.795		
N	60			2.362		
T			22.4			0.882
Ao	6.7		6.9	0.264		0.272
Bo	5.3		5.5	0.209		0.217
Ko	1.6		1.8	0.063		0.071
Po	3.9		4.1	0.153		0.161
P	7.9		8.1	0.311		0.319

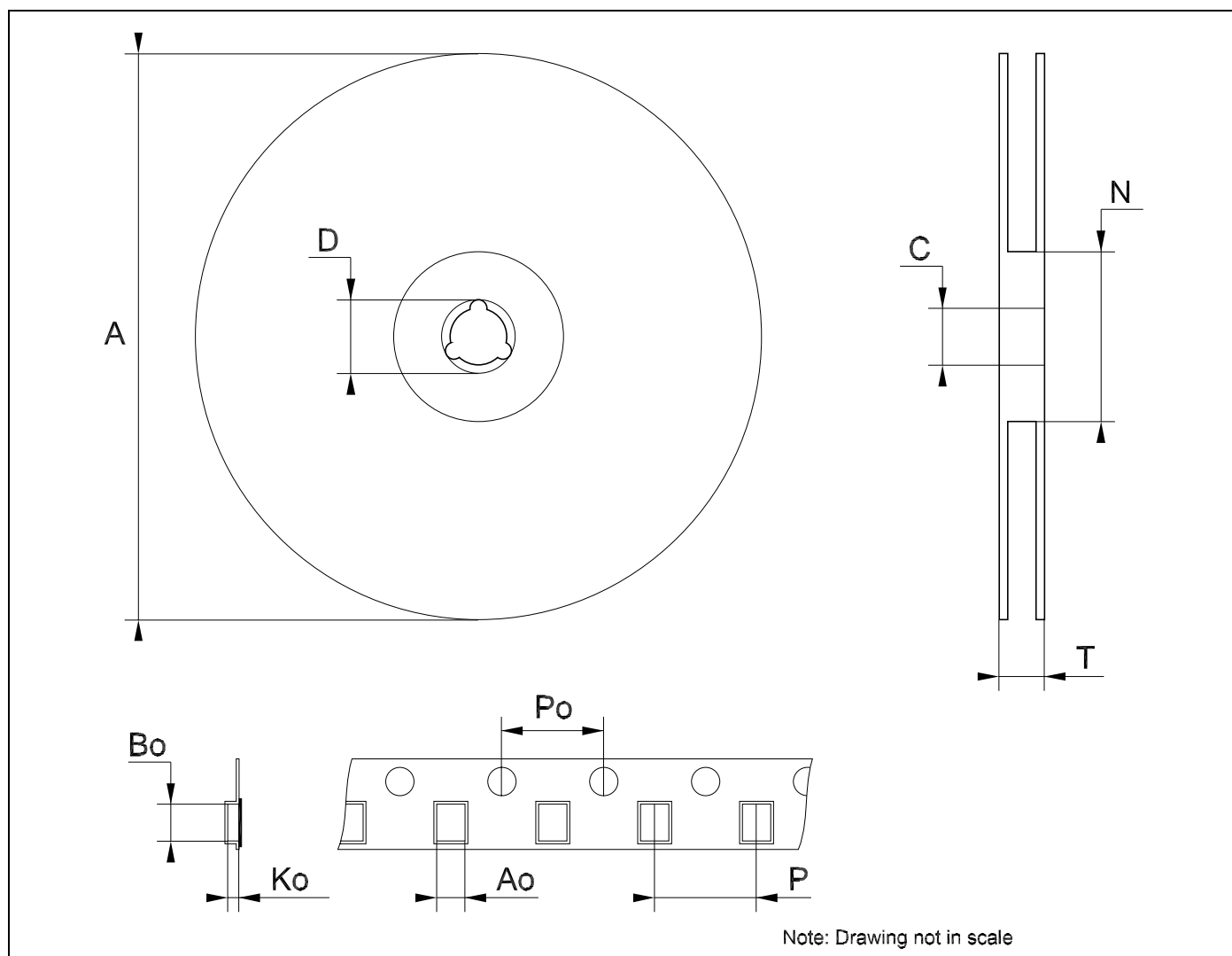

## 74LCX257

---

**Table 10: Revision History**

Date	Revision	Description of Changes
15-Sep-2004	4	Ordering Codes Revision - pag. 1.

Information furnished is believed to be accurate and reliable. However, STMicroelectronics assumes no responsibility for the consequences of use of such information nor for any infringement of patents or other rights of third parties which may result from its use. No license is granted by implication or otherwise under any patent or patent rights of STMicroelectronics. Specifications mentioned in this publication are subject to change without notice. This publication supersedes and replaces all information previously supplied. STMicroelectronics products are not authorized for use as critical components in life support devices or systems without express written approval of STMicroelectronics.

The ST logo is a registered trademark of STMicroelectronics

All other names are the property of their respective owners

© 2004 STMicroelectronics - All Rights Reserved

STMicroelectronics group of companies

Australia - Belgium - Brazil - Canada - China - Czech Republic - Finland - France - Germany - Hong Kong - India - Israel - Italy - Japan - Malaysia - Malta - Morocco - Singapore - Spain - Sweden - Switzerland - United Kingdom - United States of America

[www.st.com](http://www.st.com)