

Excellent Integrated System Limited

Stocking Distributor

Click to view price, real time Inventory, Delivery & Lifecycle Information:

[STMicroelectronics](#)
[RBO08-40G](#)

For any questions, you can email us directly:

sales@integrated-circuit.com



Application Specific Discretes
A.S.D.™

RBO08-40G/T

REVERSED BATTERY AND OVERVOLTAGE PROTECTION

FEATURES

- 8A DIODE TO GUARD AGAINST BATTERY REVERSAL.
- NEGATIVE OVERVOLTAGE PROTECTION BY CLAMPING.
- COMPLIANT WITH ISO/DTR 7637 STANDARD FOR PULSES 1, 2, 3a and 3b.
- SUITABLE FOR AUTOPROTECTED ALTERNATOR ENVIRONMENT.
- BREAKDOWN VOLTAGE : 24 V min.
- CLAMPING VOLTAGE : ± 40 V max.
- MONOLITHIC STRUCTURE FOR GREATER RELIABILITY.

DESCRIPTION

Designed to protect against battery reversal and overvoltages in automotive applications, this monolithic component offers multiple functions in the same package :

D1 : reversed battery protection

T1 : clamping against negative overvoltages

T2 : Transil function for overvoltage protection.

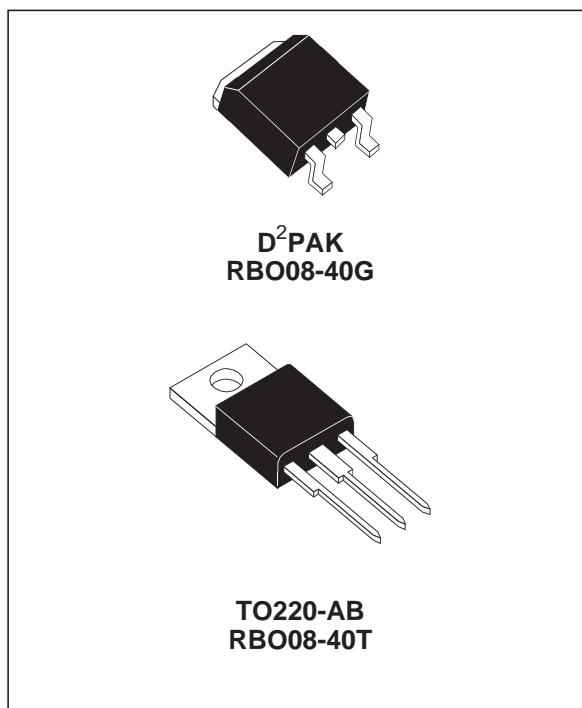

FUNCTIONAL DIAGRAM

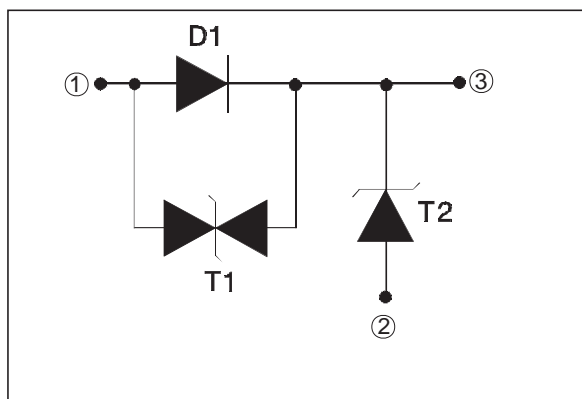

RBO08-40G / RBO08-40T

ABSOLUTE MAXIMUM RATINGS

Symbol	Parameter		Value	Unit
I_{FSM}	Non repetitive surge peak forward current (Diode D1)	$t_p = 10 \text{ ms}$	80	A
I_F	DC forward current (Diode D1)	$T_C = 75^\circ\text{C}$	8	A
P_{PP}	Peak pulse power between Input and Output (Transil T1) see note 1 T_j initial = 25°C	10/1000 μs	600	W
P_{PP}	Peak pulse power between Pins 3 and 2 (10/1000 μs)		1500	W
T_{stg} T_j	Storage temperature range Maximum junction temperature		- 40 to + 150 150	$^\circ\text{C}$
T_L	Maximum lead temperature for soldering during 10 s at 4.5mm from case for TO220-AB		260	$^\circ\text{C}$

Note 1 : for a surge greater than the maximum value, the device will fail in short-circuit..

THERMAL RESISTANCE

Symbol	Parameter		Value	Unit
$R_{th(j-c)}$	Junction to case	RBO08-40M RBO08-40T	2.4 2.4	$^\circ\text{C}/\text{W}$

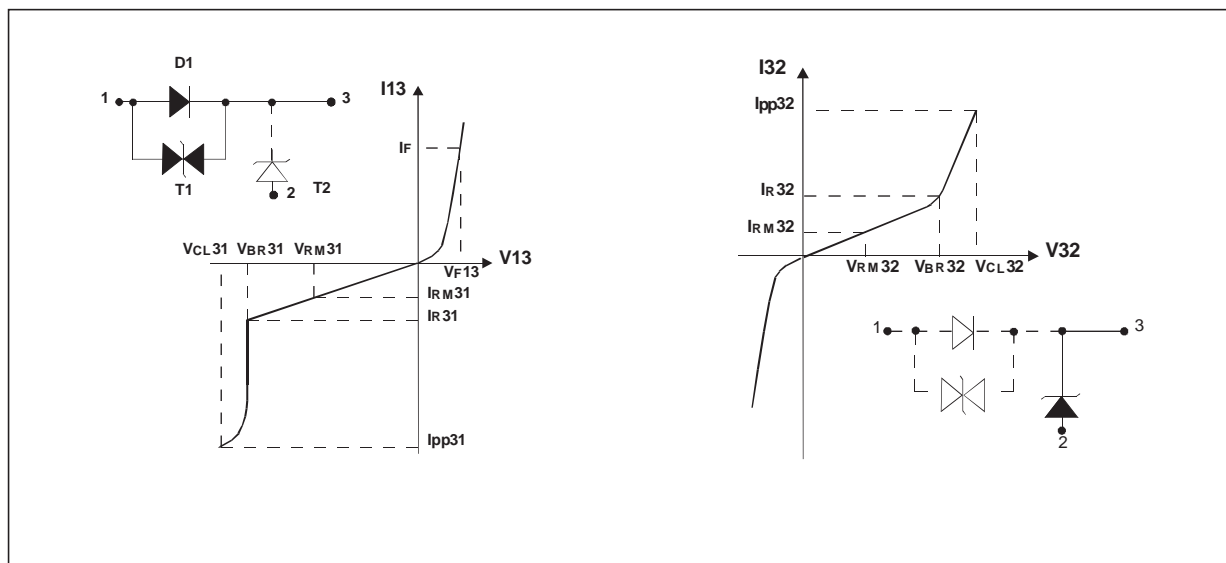

RBO08-40G / RBO08-40T

Symbol	Parameter
V_{RM31}/V_{RM32}	Stand-off voltage Transil T1 / Transil T2.
V_{BR31}/V_{BR32}	Breakdown voltage Transil T1 / Transil T2.
I_{R31}/I_{R32}	Leakage current Transil T1 / Transil T2.
V_{CL31}/V_{CL32}	Clamping voltage Transil T1 / Transil T2.
V_{F13}	Forward voltage drop Diode D1.
I_{PP}	Peak pulse current.
αT	Temperature coefficient of V_{BR} .
C_{31}/C_{32}	Capacitance Transil T1 / Transil T2.

ELECTRICAL CHARACTERISTICS : DIODE D1 (- 40°C < T_{amb} < + 85°C)

Symbol	Test Conditions	Value			Unit
		Min.	Typ.	Max.	
V_{F13}	$I_F = 8\text{ A}$	RBO08-40G		1.5	V
		RBO08-40T		1.7	V
	$I_F = 8\text{ A @ } T_{amb} = 25^\circ\text{C}$			1.45	V
V_{F13}	$I_F = 4\text{ A}$	RBO08-40G		1.3	V
		RBO08-40T		1.35	V
	$I_F = 4\text{ A @ } T_{amb} = 25^\circ\text{C}$			1.2	V
V_{F13}	$I_F = 1\text{ A}$			1.1	V
		$I_F = 1\text{ A @ } T_{amb} = 25^\circ\text{C}$			1.0
	$I_F = 1\text{ A @ } T_j = 85^\circ\text{C}$			0.9	V

ELECTRICAL CHARACTERISTICS : TRANSIL T1 (- 40°C < T_{amb} < + 85°C)

Symbol	Test Conditions	Value			Unit
		Min.	Typ.	Max.	
V_{BR31}	$I_R = 1\text{ mA}$	22		35	V
V_{BR31}	$I_R = 1\text{ mA}, T_{amb} = 25^\circ\text{C}$	24		32	V
I_{RM31}	$V_{RM} = 20\text{ V}$			50	μA
I_{RM31}	$V_{RM} = 20\text{ V}, T_{amb} = 25^\circ\text{C}$			10	μA
V_{CL31}	$I_{PP} = 15\text{ A}, T_j \text{ initial} = 25^\circ\text{C}$		10/1000 μs	40	V
αT	Temperature coefficient of V_{BR}			9	$10^{-4}/^\circ\text{C}$
C_{31}	$F = 1\text{ MHz } V_R = 0\text{ V}$		1000		pF

ELECTRICAL CHARACTERISTICS : TRANSIL T2 (- 40°C < T_{amb} < + 85°C)

Symbol	Test Conditions	Value			Unit
		Min.	Typ.	Max.	
V_{BR32}	$I_R = 1\text{ mA}$	22		35	V
V_{BR32}	$I_R = 1\text{ mA}, T_{amb} = 25^\circ\text{C}$	24		32	V
I_{RM32}	$V_{RM} = 20\text{ V}$			50	μA
I_{RM32}	$V_{RM} = 20\text{ V}, T_{amb} = 25^\circ\text{C}$			10	μA
V_{CL32}	$I_{PP} = 37.5\text{ A}$		10/1000 μs	40	V
αT	Temperature coefficient of V_{BR}			8.5	$10^{-4}/^\circ\text{C}$

RBO08-40G / RBO08-40T

PRODUCT DESCRIPTION

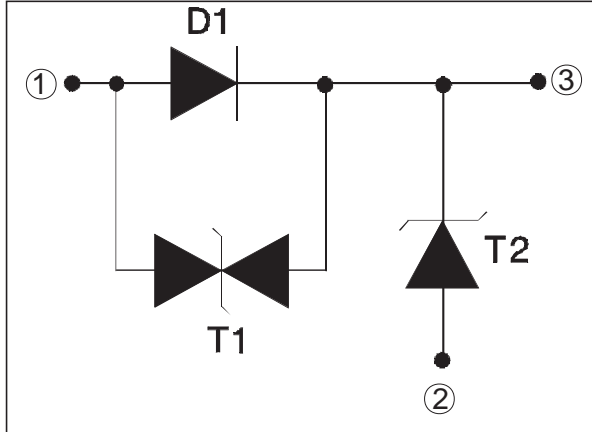

The RBO has 3 functions integrated on the same chip.

D1 : "Diode function" in order to protect against reversed battery operation.

T2 : "Transil function" in order to protect against positive surge generated by electric systems (ignition, relay. ...).

T1 : Protection against negative surges such as inductive overvoltages (see motor application below).

BASIC APPLICATION

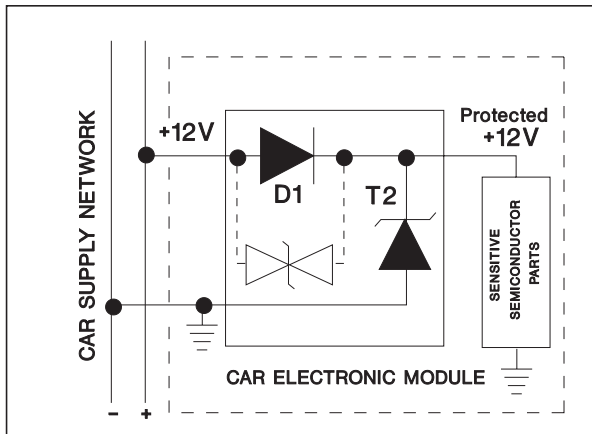

* The monolithic multi-function protection (RBO) has been developed to protect sensitive semiconductors in car electronic modules against both overvoltage and battery reverse.

* In addition, the RBO circuit prevents overvoltages generated by the module from affecting the car supply network.

MOTOR DRIVER APPLICATION

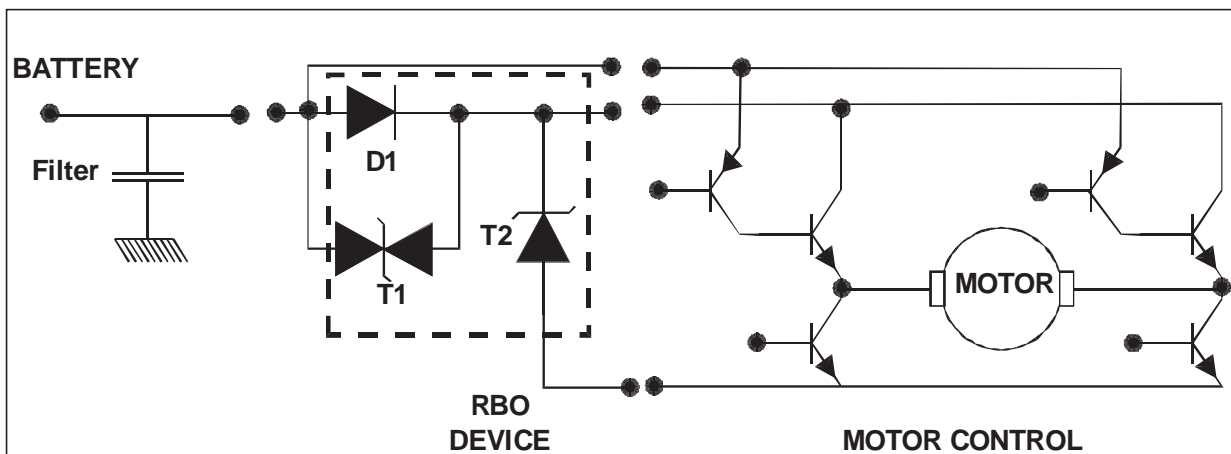

In this application, one half of the motor drive circuit is supplied through the "RBO" and is thus protected as per its basic function application.

The second part is connected directly to the "car supply network" and is protected as follows :

- For positive surges : T2 (clamping phase) and D1 in forward-biased.
- For negative surges : T1 (clamping phase) and T2 in forward-biased.

RBO08-40G / RBO08-40T

PINOUT configuration in D²PAK :

- Input (1) : Pin 1
- Output (3) : Pin 3
- Gnd (2) : Connected to base Tab

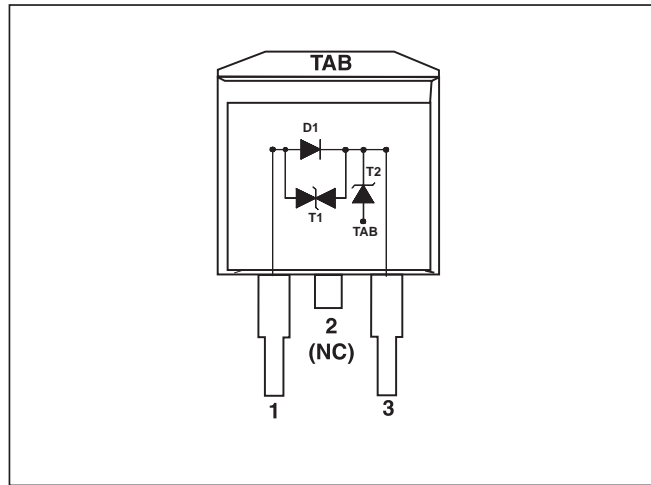

PINOUT configuration in TO220AB :

- Input (1) : Pin 1
- Output (3) : Pin 3
- GND (2) : Connected to base Tab

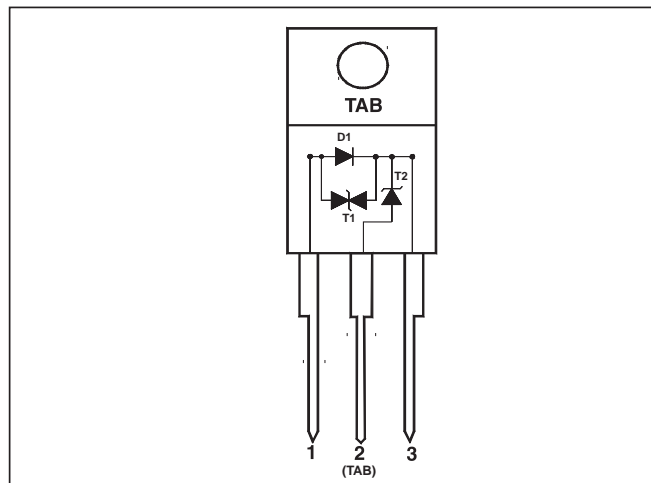

RBO08-40G / RBO08-40T

Fig. 1 : Peak pulse power versus exponential pulse duration (T_j initial = 85°C).

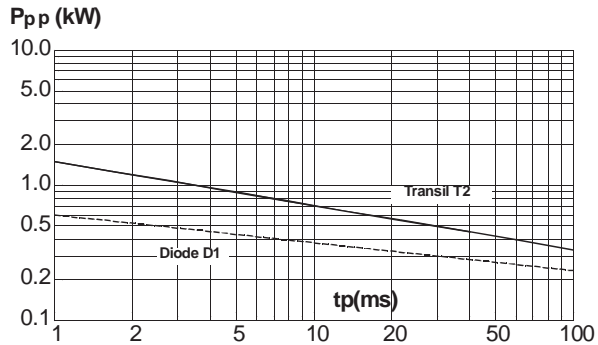

Fig. 2-1 : Clamping voltage versus peak pulse current (T_j initial = 85°C).

Exponential waveform $t_p = 40$ ms and $t_p = 1$ ms (TRANSIL T2).

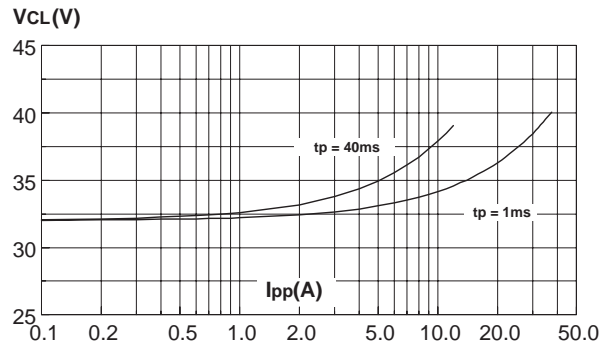

Fig. 2-2 : Clamping voltage versus peak pulse current (T_j initial = 85°C).

Exponential waveform $t_p = 1$ ms and $t_p = 20 \mu s$ (TRANSIL T1).

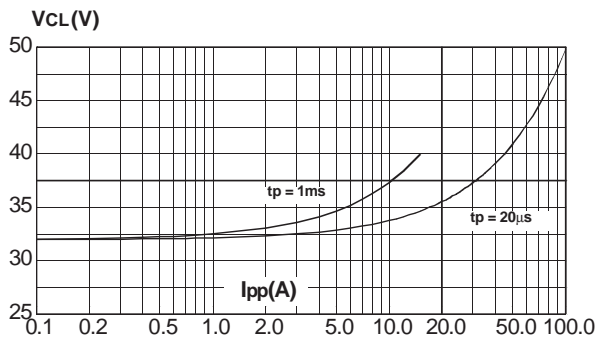
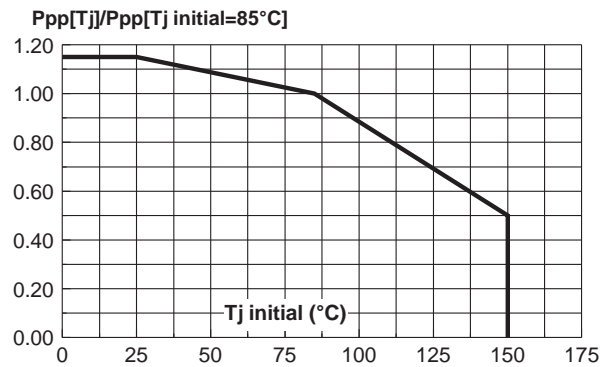

Fig. 3 : Relative variation of peak pulse power versus junction temperature.



RBO08-40G / RBO08-40T

Fig. 4 : Relative variation of thermal impedance junction to case versus pulse duration.

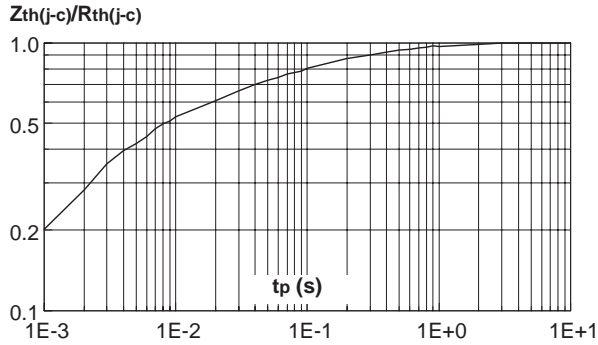

Fig. 5-1 : Peak forward voltage drop versus peak forward current (typical values) - (TRANSIL T2).

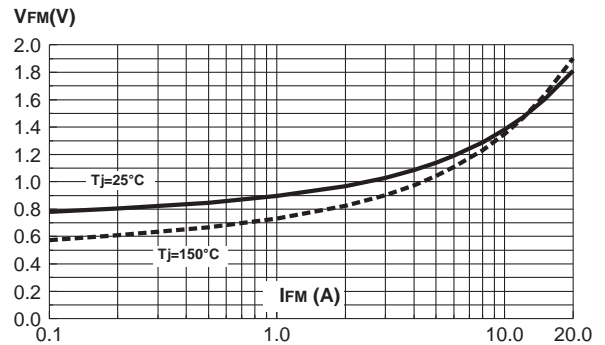

Fig. 5-2 : Peak forward voltage drop versus peak forward current (typical values) - (DIODE D1).

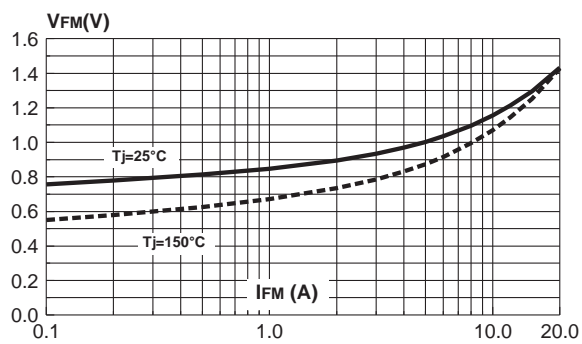
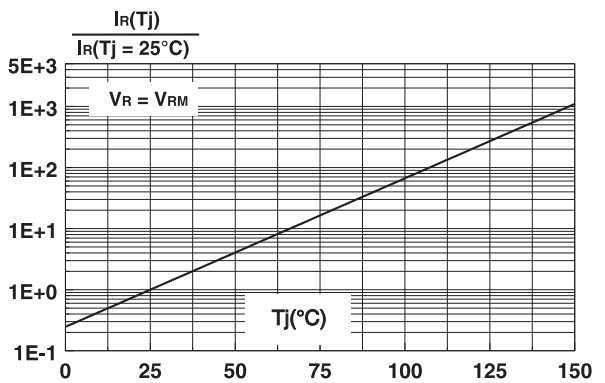
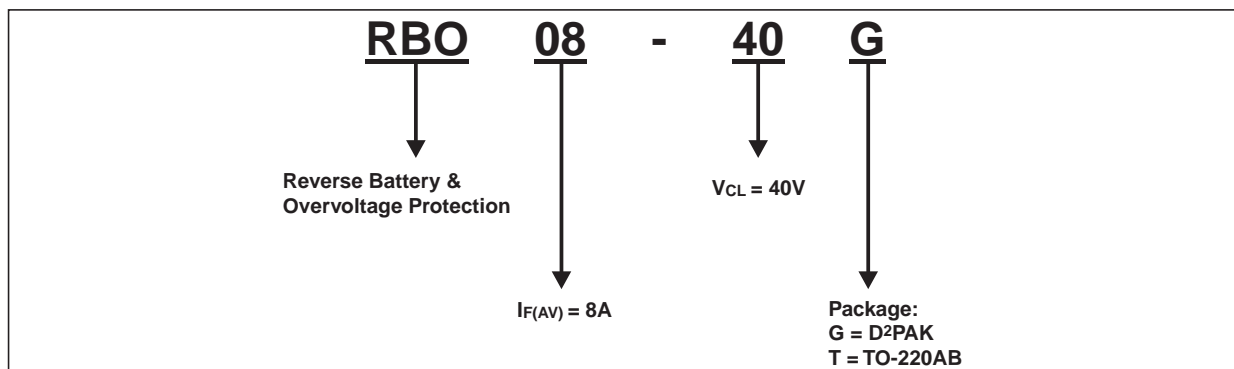

Fig. 6 : Relative variation of leakage current versus junction temperature.



ORDERING INFORMATION



RBO08-40G / RBO08-40T

PACKAGE MECHANICAL DATA

D²PAK Plastic

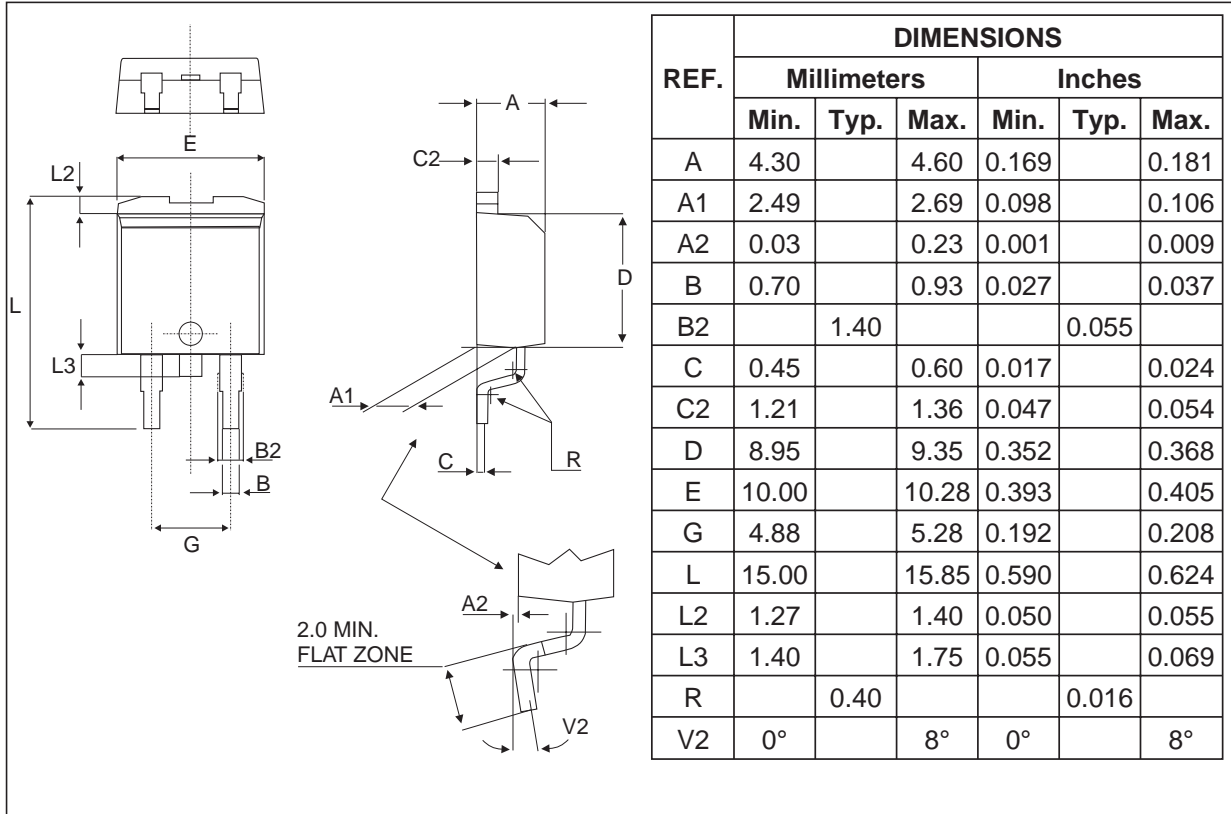

FOOT-PRINT D²PAK

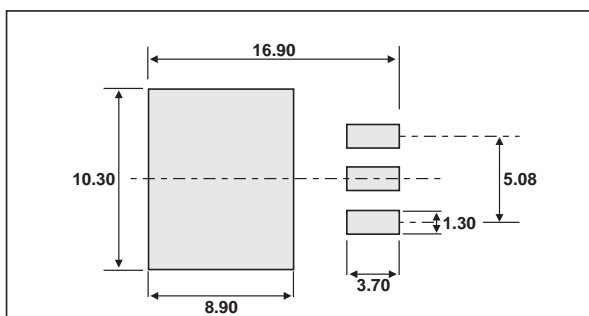

RBO08-40G / RBO08-40T

PACKAGE MECHANICAL DATA

TO-220AB Plastic

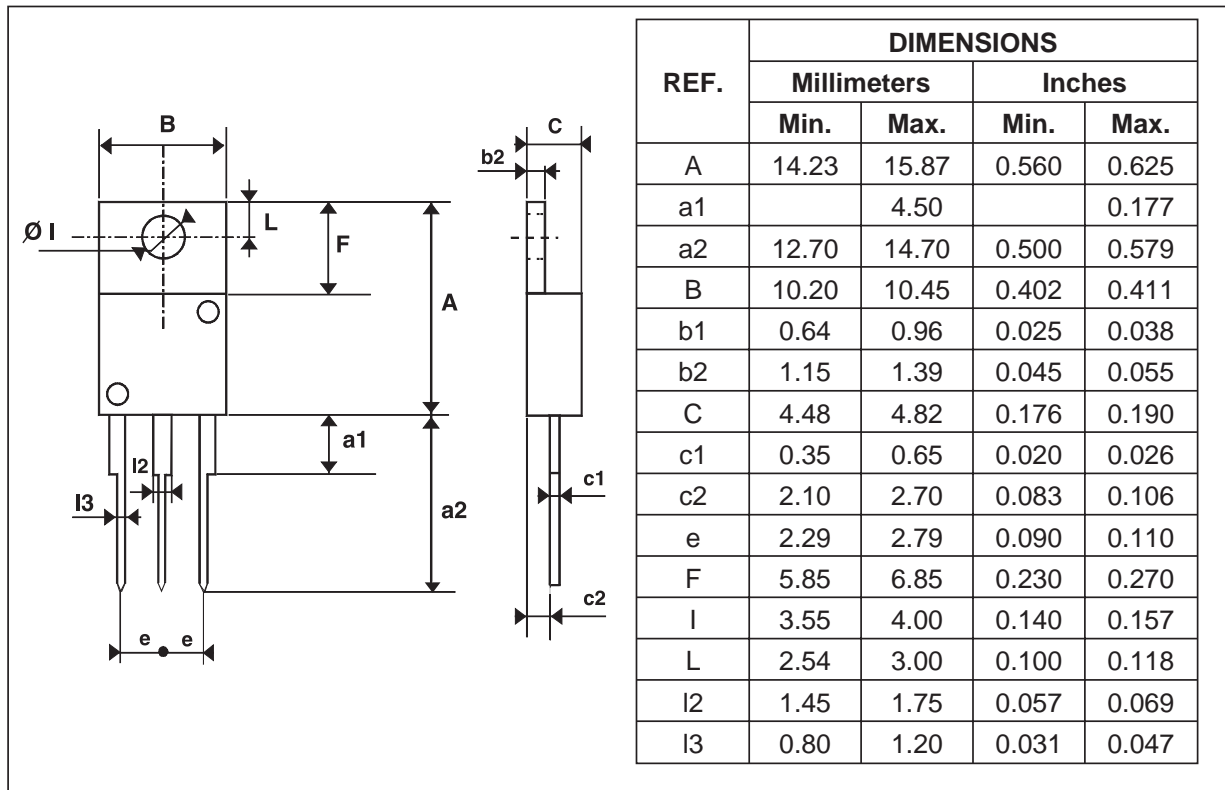

Information furnished is believed to be accurate and reliable. However, STMicroelectronics assumes no responsibility for the consequences of use of such information nor for any infringement of patents or other rights of third parties which may result from its use. No license is granted by implication or otherwise under any patent or patent rights of STMicroelectronics. Specifications mentioned in this publication are subject to change without notice. This publication supersedes and replaces all information previously supplied. STMicroelectronics products are not authorized for use as critical components in life support devices or systems without express written approval of STMicroelectronics.

The ST logo is a registered trademark of STMicroelectronics.

All other names are the property of their respective owners.

© 2003 STMicroelectronics - All rights reserved.

STMicroelectronics GROUP OF COMPANIES

Australia - Belgium - Brazil - Canada - China - Czech Republic - Finland - France - Germany - Hong Kong - India - Israel - Italy - Japan - Malaysia - Malta - Morocco - Singapore - Spain - Sweden - Switzerland - United Kingdom - United States

www.st.com