

Excellent Integrated System Limited

Stocking Distributor

Click to view price, real time Inventory, Delivery & Lifecycle Information:

[STMicroelectronics](#)
[STP20NM60FD](#)

For any questions, you can email us directly:

sales@integrated-circuit.com



STF20NM60D - STP20NM60FD STW20NM60FD

N-channel 600V - 0.26Ω - 20A - TO-220 - TO-220FP - TO-247
 FDmesh™ Power MOSFET (with fast diode)

General features

Type	V _{DSS}	R _{DS(on)}	I _D	P _w
STF20NM60D	600V	<0.29Ω	20A	192W
STP20NM60FD	600V	<0.29Ω	20A	45W
STW20NM60FD	600V	<0.29Ω	20A	214W

- High dv/dt and avalanche capabilities
- 100% Avalanche tested
- Low input capacitance and gate charge
- Low gate input resistance
- Tight process control and high manufacturing yields

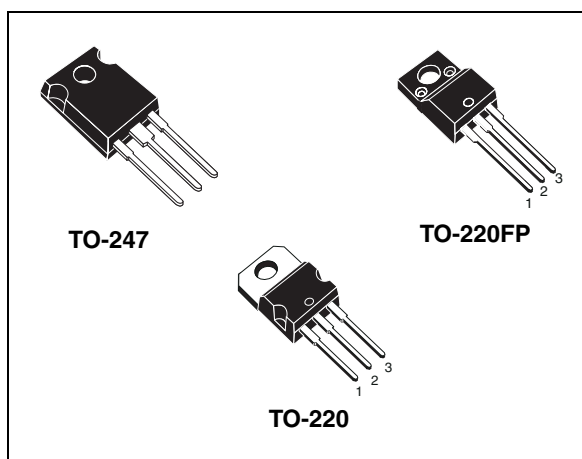

Description

The FDmesh™ associates all advantages of reduced on-resistance and fast switching with an intrinsic fast-recovery body diode. It is therefore strongly recommended for bridge topologies, in particular ZVS phase-shift converters.

Applications

- Switching application

Internal schematic diagram

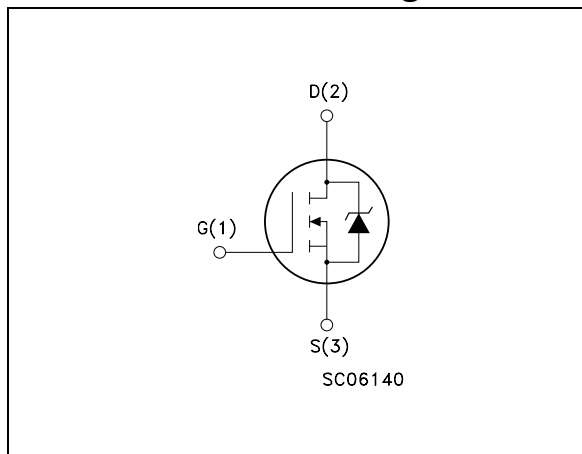

Order codes

Part number	Marking	Package	Packaging
STF20NM60D	F20NM60D	TO-220FP	Tube
STP20NM60FD	P20NM60FD	TO-220	Tube
STW20NM60FD	W20NM60FD	TO-247	Tube

Contents

1	Electrical ratings	3
2	Electrical characteristics	4
2.1	Electrical characteristics (curves)	6
3	Test circuit	9
4	Package mechanical data	10
5	Revision history	14

STF20NM60D - STP20NM60FD - STW20NM60FD

Electrical ratings

1 Electrical ratings

Table 1. Absolute maximum ratings

Symbol	Parameter	Value			Unit
		TO-220	TO-220FP	TO-247	
V _{DS}	Drain-source voltage (V _{GS} = 0)	600			V
V _{DGR}	Drain-gate voltage (R _{GS} = 20 kΩ)	600			V
V _{GS}	Gate- source voltage	± 30			V
I _D	Drain current (continuous) at T _C = 25°C	20	20 ⁽¹⁾	20	A
I _D	Drain current (continuous) at T _C = 100°C	12.6	12.6 ⁽¹⁾	12.6	A
I _{DM} ⁽²⁾	Drain current (pulsed)	80	80 ⁽¹⁾	80	A
P _{TOT}	Total dissipation at T _C = 25°C	192	45	214	W
	Derating factor	1.20	0.36	1.42	W/°C
dv/dt ⁽³⁾	Peak diode recovery voltage slope	20			V/ns
V _{ISO}	Insulation withstand voltage (DC)	-	2500	-	V
T _j T _{stg}	Operating junction temperature Storage temperature	- 65 to 150			°C °C

- Limited only by maximum temperature allowed
- Pulse width limited by safe operating area
- I_{SD} ≤ 20A, di/dt ≤ 400A/μs, V_{DD} = 80%V_{(BR)DSS}

Table 2. Thermal resistance

Symbol	Parameter	Value			Unit
		TO-220	TO-220FP	TO-247	
R _{thj-case}	Thermal resistance junction-case Max	0.65	2.8	0.585	°C/W
R _{thj-amb}	Thermal resistance junction-ambient Max	62.5		30	°C/W
T _l	Maximum lead temperature for soldering purpose	300			°C

Table 3. Avalanche data

Symbol	Parameter	Value	Unit
I _{AR}	Avalanche current, repetitive or not-repetitive (pulse width limited by T _j max)	10	A
E _{AS}	Single pulse avalanche energy (starting T _j = 25 °C, I _D = I _{AR} , V _{DD} = 35 V)	700	mJ

Electrical characteristics

STF20NM60D - STP20NM60FD - STW20NM60FD

2 Electrical characteristics

(T_{CASE}=25°C unless otherwise specified)

Table 4. On/off states

Symbol	Parameter	Test conditions	Min	Typ	Max	Unit
V _{(BR)DSS}	Drain-source breakdown voltage	I _D = 250μA, V _{GS} = 0	600			V
I _{DSS}	Zero gate voltage drain current (V _{GS} = 0)	V _{DS} = Max rating V _{DS} = Max rating, T _C = 125 °C			1 10	μA μA
I _{GSS}	Gate-body leakage current (V _{DS} = 0)	V _{GS} = ±30V			±10 0	μA
V _{GS(th)}	Gate threshold voltage	V _{DS} = V _{GS} , I _D = 250μA	3	4	5	V
R _{DS(on)}	Static drain-source on resistance	V _{GS} = 10V, I _D = 10A		0.26	0.29	Ω

Table 5. Dynamic

Symbol	Parameter	Test conditions	Min	Typ	Max	Unit
g _{fs} ⁽¹⁾	Forward transconductance	V _{DS} > I _{D(on)} × R _{DS(on)max} , I _D = 10A		9		S
C _{iss} C _{oss} C _{rss}	Input capacitance Output capacitance Reverse transfer capacitance	V _{DS} = 25V, f = 1 MHz, V _{GS} = 0		1300 500 35		pF pF pF
C _{oss eq.} ⁽²⁾	Equivalent output capacitance	V _{GS} = 0V, V _{DS} = 0V to 480V		190		pF
R _G	Gate input resistance	f=1 MHz Gate DC Bias = 0 Test signal level = 20mV open drain		2.7		Ω
Q _g Q _{gs} Q _{gd}	Total gate charge Gate-source charge Gate-drain charge	V _{DD} = 480V, I _D = 20A, V _{GS} = 10V <i>(see Figure 17)</i>		37 10 17	52	nC nC nC

1. Pulsed: Pulse duration = 300 μs, duty cycle 1.5 %
2. C_{oss eq.} is defined as a constant equivalent capacitance giving the same charging time as C_{oss} when V_{DS} increases from 0 to 80%

STF20NM60D - STP20NM60FD - STW20NM60FD
Electrical characteristics
Table 6. Switching times

Symbol	Parameter	Test conditions	Min.	Typ.	Max.	Unit
$t_{d(on)}$	Turn-on delay time	$V_{DD} = 300V, I_D = 10A$ $R_G = 4.7\Omega, V_{GS} = 10V$ <i>(see Figure 16)</i>		25		ns
t_r	Rise time			12		ns
$t_{r(Voff)}$	Off-voltage rise time	$V_{DD} = 480V, I_D = 20A,$ $R_G = 4.7\Omega, V_{GS} = 10V$ <i>(see Figure 16)</i>		8		ns
t_f	Fall time			22		ns
t_c	Cross-over time			30		ns

Table 7. Source drain diode

Symbol	Parameter	Test conditions	Min	Typ.	Max	Unit
I_{SD}	Source-drain current				20	A
$I_{SDM}^{(1)}$	Source-drain current (pulsed)				80	A
$V_{SD}^{(2)}$	Forward on voltage	$I_{SD} = 20A, V_{GS} = 0$			1.5	V
t_{rr}	Reverse recovery time	$I_{SD} = 20A, T_j = 25^\circ C$ $di/dt = 100A/\mu s, V_{DD} = 60V$ <i>(see Figure 21)</i>		240		ns
Q_{rr}	Reverse recovery charge			1800		nC
I_{RRM}	Reverse recovery current			16		A
t_{rr}	Reverse recovery time	$I_{SD} = 20A, T_j = 150^\circ C$ $di/dt = 100A/\mu s, V_{DD} = 60V$ <i>(see Figure 21)</i>		396		ns
Q_{rr}	Reverse recovery charge			2960		nC
I_{RRM}	Reverse recovery current			20		A

1. Pulse width limited by safe operating area
2. Pulsed: Pulse duration = 300 μs , duty cycle 1.5 %.

Electrical characteristics

STF20NM60D - STP20NM60FD - STW20NM60FD

2.1 Electrical characteristics (curves)

Figure 1. Safe operating area for TO-220

Figure 2. Thermal impedance for TO-220

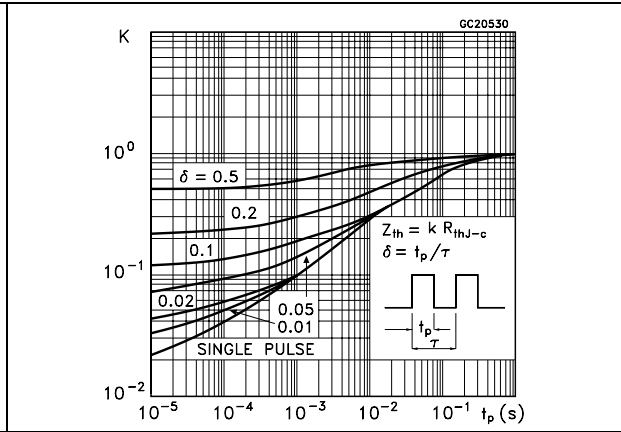
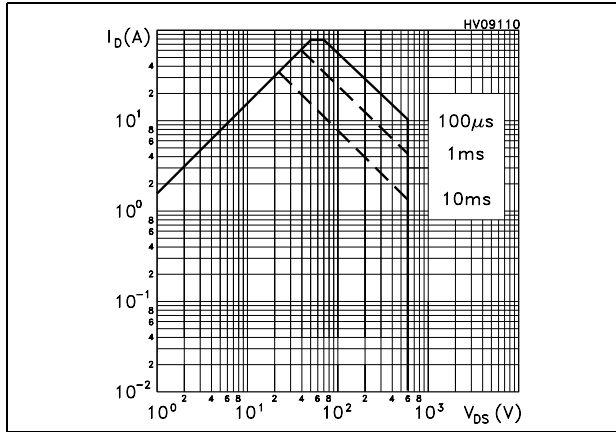

Figure 3. Safe operating area for TO-220FP

Figure 4. Thermal impedance for TO-220FP

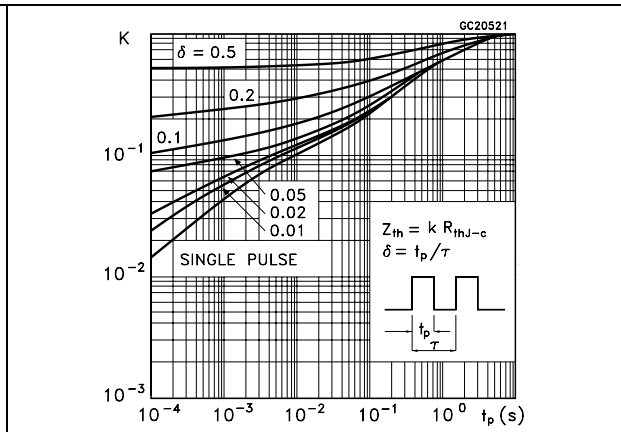
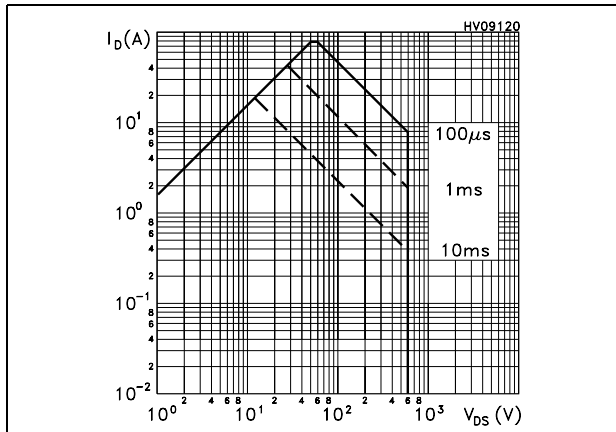
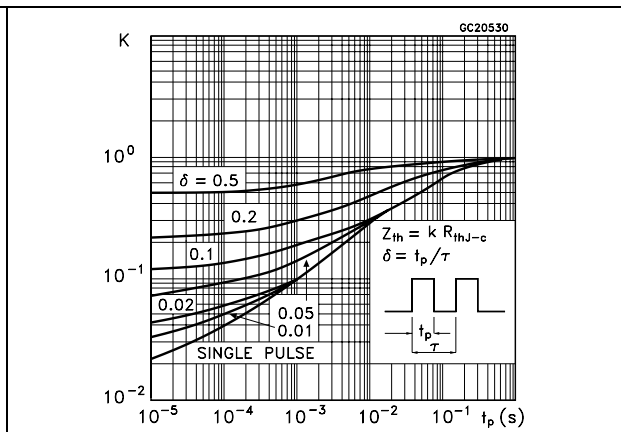
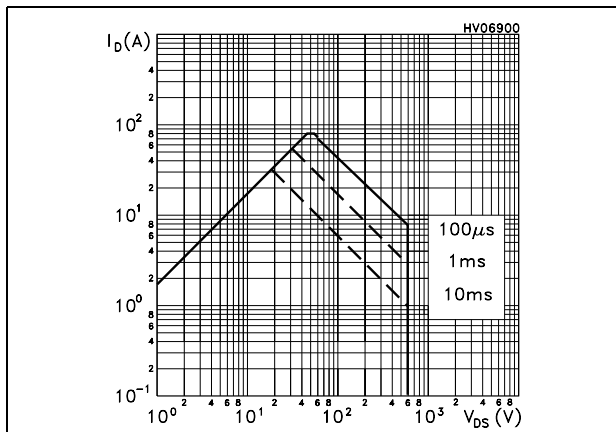

Figure 5. Safe operating area for TO-247

Figure 6. Thermal impedance for TO-247



STF20NM60D - STP20NM60FD - STW20NM60FD

Electrical characteristics

Figure 7. Output characteristics

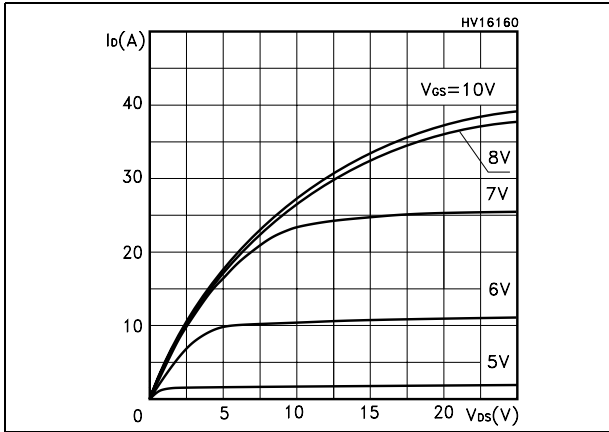

Figure 8. Transfer characteristics

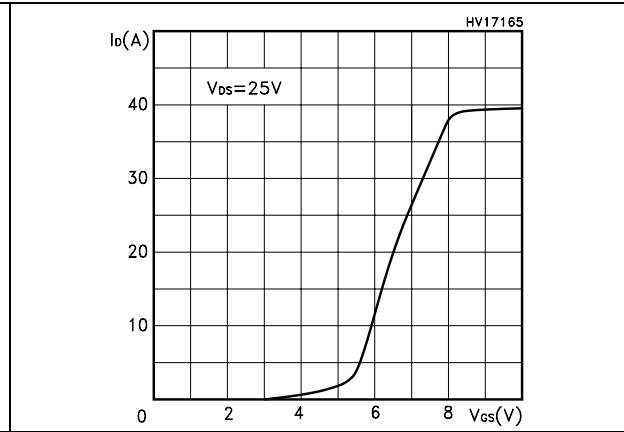

Figure 9. Transconductance

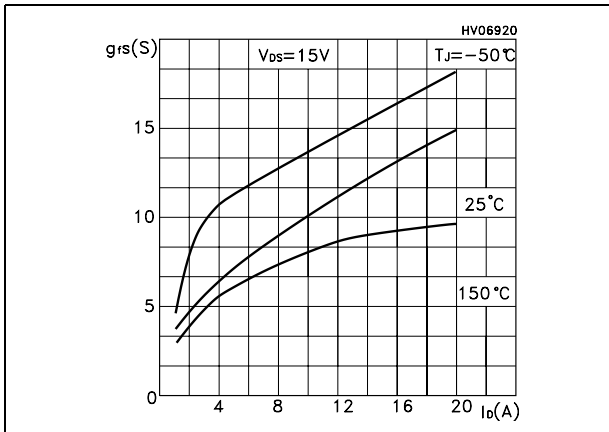

Figure 10. Static drain-source on resistance

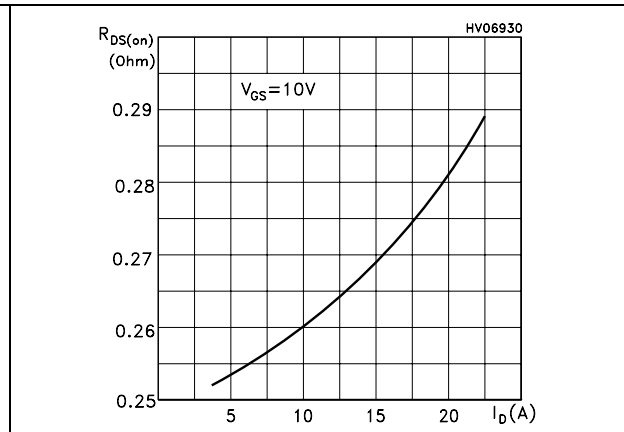
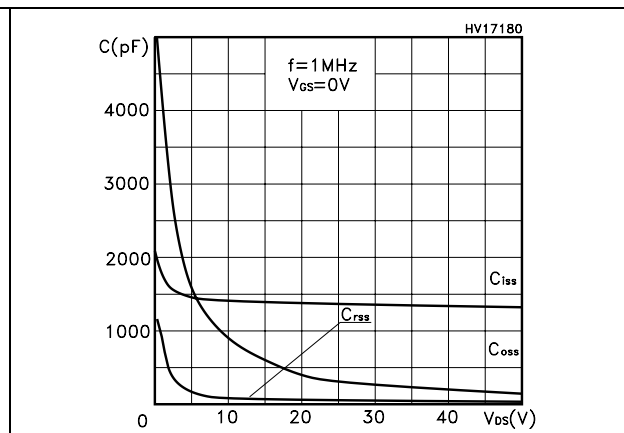
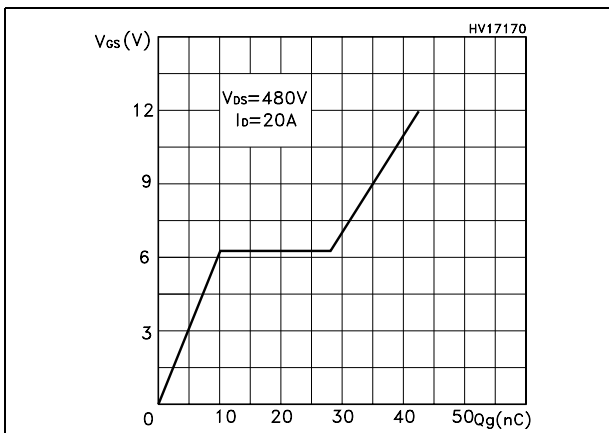

Figure 11. Gate charge vs gate-source voltage **Figure 12. Capacitance variations**



Electrical characteristics

STF20NM60D - STP20NM60FD - STW20NM60FD

Figure 13. Normalized gate threshold voltage vs temperature

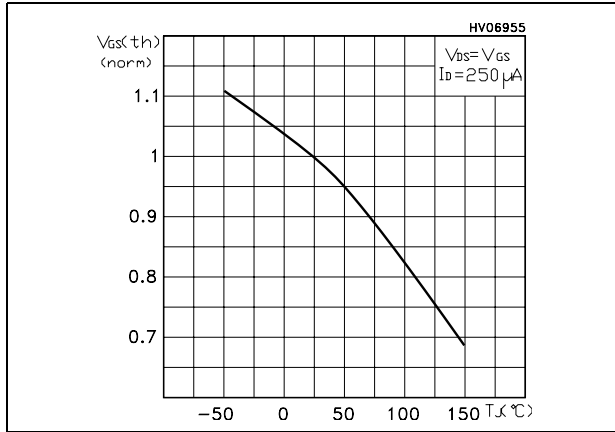

Figure 14. Normalized on resistance vs temperature

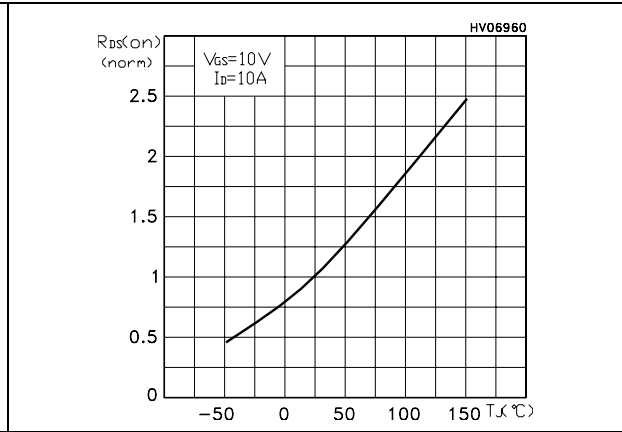
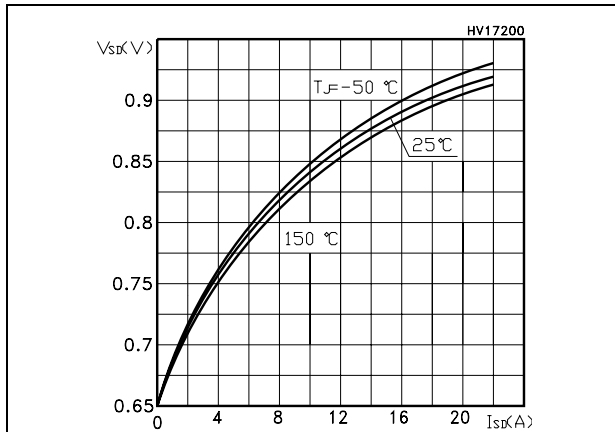

Figure 15. Source-drain diode forward characteristics



STF20NM60D - STP20NM60FD - STW20NM60FD

Test circuit

3 Test circuit

Figure 16. Switching times test circuit for resistive load

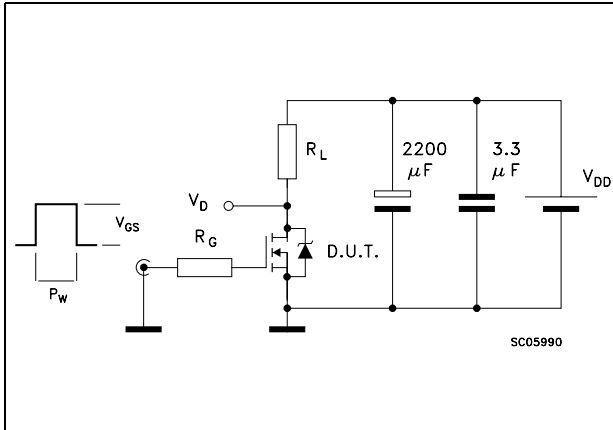

Figure 17. Gate charge test circuit

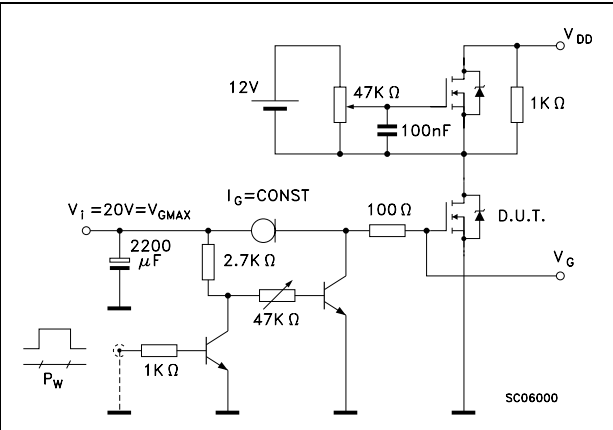

Figure 18. Test circuit for inductive load switching and diode recovery times

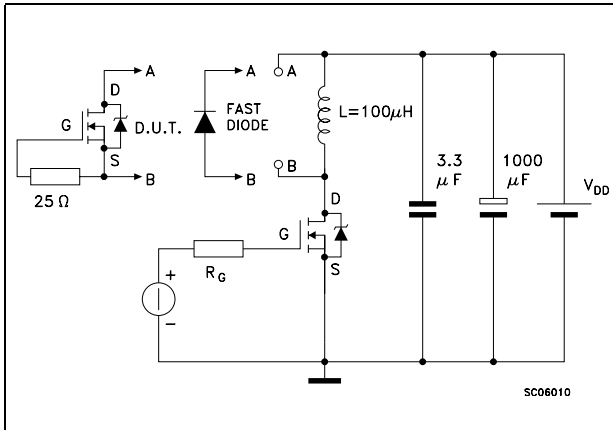

Figure 19. Unclamped inductive load test circuit

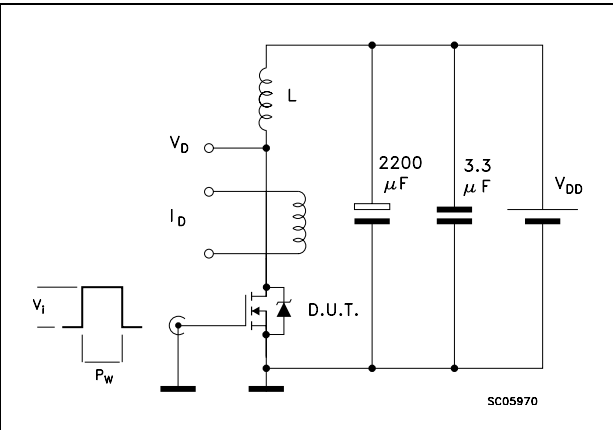

Figure 20. Unclamped inductive waveform

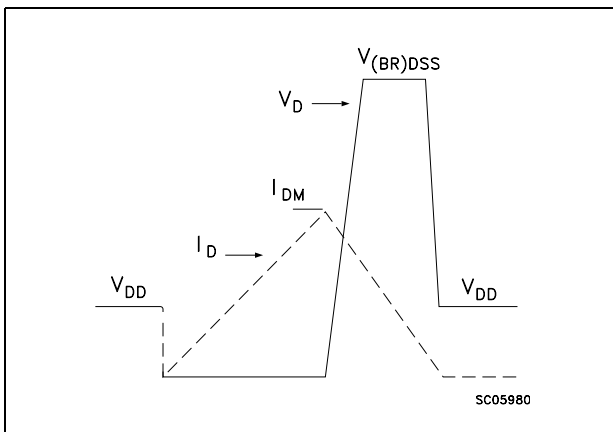
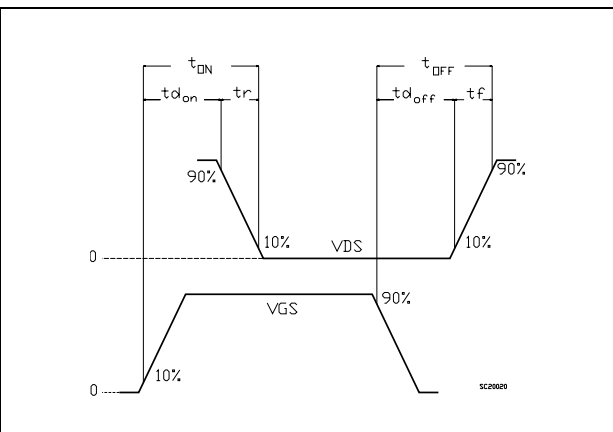

Figure 21. Switching time waveform



4 Package mechanical data

In order to meet environmental requirements, ST offers these devices in ECOPACK® packages. These packages have a Lead-free second level interconnect . The category of second level interconnect is marked on the package and on the inner box label, in compliance with JEDEC Standard JESD97. The maximum ratings related to soldering conditions are also marked on the inner box label. ECOPACK is an ST trademark. ECOPACK specifications are available at : www.st.com

STF20NM60D - STP20NM60FD - STW20NM60FD

Package mechanical data

TO-220 MECHANICAL DATA						
DIM.	mm.			inch		
	MIN.	TYP.	MAX.	MIN.	TYP.	MAX.
A	4.40		4.60	0.173		0.181
b	0.61		0.88	0.024		0.034
b1	1.15		1.70	0.045		0.066
c	0.49		0.70	0.019		0.027
D	15.25		15.75	0.60		0.620
E	10		10.40	0.393		0.409
e	2.40		2.70	0.094		0.106
e1	4.95		5.15	0.194		0.202
F	1.23		1.32	0.048		0.052
H1	6.20		6.60	0.244		0.256
J1	2.40		2.72	0.094		0.107
L	13		14	0.511		0.551
L1	3.50		3.93	0.137		0.154
L20		16.40			0.645	
L30		28.90			1.137	
øP	3.75		3.85	0.147		0.151
Q	2.65		2.95	0.104		0.116

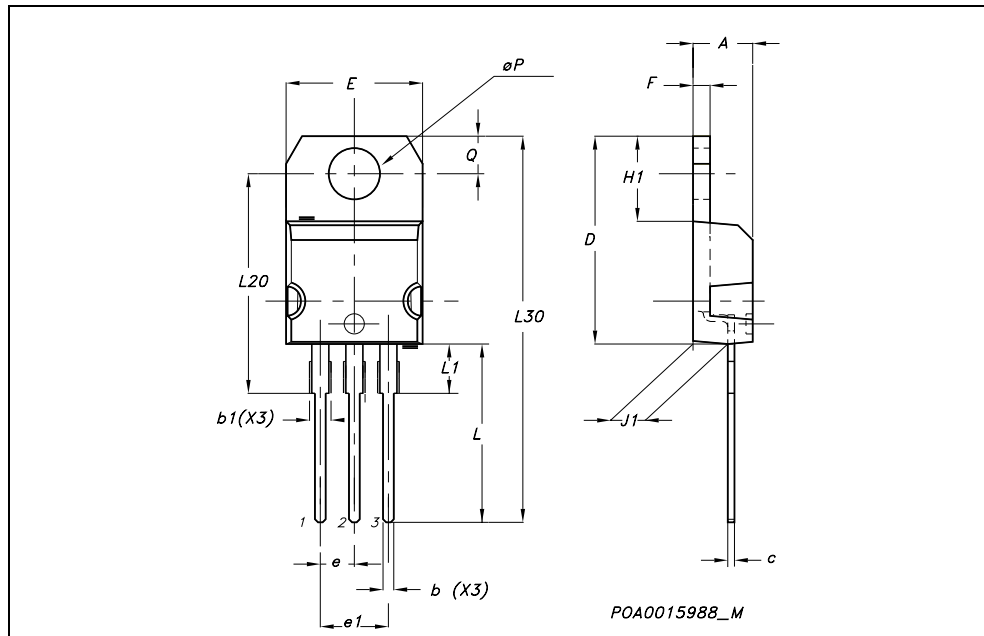

Package mechanical data

STF20NM60D - STP20NM60FD - STW20NM60FD

TO-247 MECHANICAL DATA

DIM.	mm.			inch		
	MIN.	TYP.	MAX.	MIN.	TYP.	MAX.
A	4.85		5.15	0.19		0.20
A1	2.20		2.60	0.086		0.102
b	1.0		1.40	0.039		0.055
b1	2.0		2.40	0.079		0.094
b2	3.0		3.40	0.118		0.134
c	0.40		0.80	0.015		0.03
D	19.85		20.15	0.781		0.793
E	15.45		15.75	0.608		0.620
e		5.45			0.214	
L	14.20		14.80	0.560		0.582
L1	3.70		4.30	0.14		0.17
L2		18.50			0.728	
øP	3.55		3.65	0.140		0.143
øR	4.50		5.50	0.177		0.216
S		5.50			0.216	

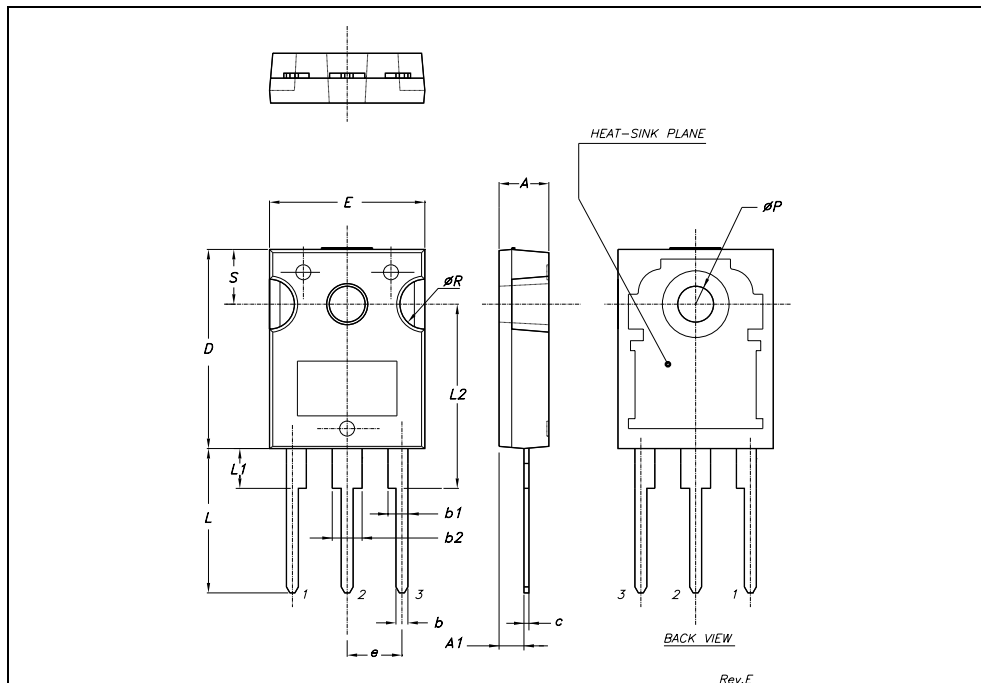

STF20NM60D - STP20NM60FD - STW20NM60FD

Package mechanical data

TO-220FP MECHANICAL DATA

DIM.	mm.			inch		
	MIN.	TYP.	MAX.	MIN.	TYP.	MAX.
A	4.4		4.6	0.173		0.181
B	2.5		2.7	0.098		0.106
D	2.5		2.75	0.098		0.108
E	0.45		0.7	0.017		0.027
F	0.75		1	0.030		0.039
F1	1.15		1.7	0.045		0.067
F2	1.15		1.7	0.045		0.067
G	4.95		5.2	0.195		0.204
G1	2.4		2.7	0.094		0.106
H	10		10.4	0.393		0.409
L2		16			0.630	
L3	28.6		30.6	1.126		1.204
L4	9.8		10.6	.0385		0.417
L5	2.9		3.6	0.114		0.141
L6	15.9		16.4	0.626		0.645
L7	9		9.3	0.354		0.366
Ø	3		3.2	0.118		0.126

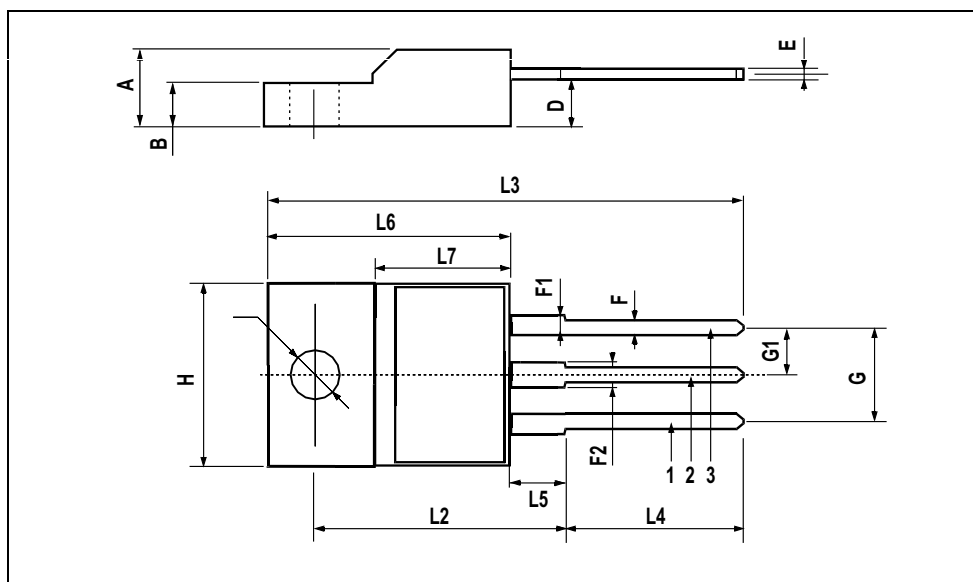

5 Revision history

Table 8. Revision history

Date	Revision	Changes
09-Sep-2004	1	First release
21-Apr-2006	2	New template
25-Jul-2006	3	Modified part number
01-Aug-2006	4	Corrected unit on Table 5.: Dynamic

STF20NM60D - STP20NM60FD - STW20NM60FD

Please Read Carefully:

Information in this document is provided solely in connection with ST products. STMicroelectronics NV and its subsidiaries ("ST") reserve the right to make changes, corrections, modifications or improvements, to this document, and the products and services described herein at any time, without notice.

All ST products are sold pursuant to ST's terms and conditions of sale.

Purchasers are solely responsible for the choice, selection and use of the ST products and services described herein, and ST assumes no liability whatsoever relating to the choice, selection or use of the ST products and services described herein.

No license, express or implied, by estoppel or otherwise, to any intellectual property rights is granted under this document. If any part of this document refers to any third party products or services it shall not be deemed a license grant by ST for the use of such third party products or services, or any intellectual property contained therein or considered as a warranty covering the use in any manner whatsoever of such third party products or services or any intellectual property contained therein.

UNLESS OTHERWISE SET FORTH IN ST'S TERMS AND CONDITIONS OF SALE ST DISCLAIMS ANY EXPRESS OR IMPLIED WARRANTY WITH RESPECT TO THE USE AND/OR SALE OF ST PRODUCTS INCLUDING WITHOUT LIMITATION IMPLIED WARRANTIES OF MERCHANTABILITY, FITNESS FOR A PARTICULAR PURPOSE (AND THEIR EQUIVALENTS UNDER THE LAWS OF ANY JURISDICTION), OR INFRINGEMENT OF ANY PATENT, COPYRIGHT OR OTHER INTELLECTUAL PROPERTY RIGHT.

UNLESS EXPRESSLY APPROVED IN WRITING BY AN AUTHORIZED ST REPRESENTATIVE, ST PRODUCTS ARE NOT RECOMMENDED, AUTHORIZED OR WARRANTED FOR USE IN MILITARY, AIR CRAFT, SPACE, LIFE SAVING, OR LIFE SUSTAINING APPLICATIONS, NOR IN PRODUCTS OR SYSTEMS WHERE FAILURE OR MALFUNCTION MAY RESULT IN PERSONAL INJURY, DEATH, OR SEVERE PROPERTY OR ENVIRONMENTAL DAMAGE. ST PRODUCTS WHICH ARE NOT SPECIFIED AS "AUTOMOTIVE GRADE" MAY ONLY BE USED IN AUTOMOTIVE APPLICATIONS AT USER'S OWN RISK.

Resale of ST products with provisions different from the statements and/or technical features set forth in this document shall immediately void any warranty granted by ST for the ST product or service described herein and shall not create or extend in any manner whatsoever, any liability of ST.

ST and the ST logo are trademarks or registered trademarks of ST in various countries.

Information in this document supersedes and replaces all information previously supplied.

The ST logo is a registered trademark of STMicroelectronics. All other names are the property of their respective owners.

© 2006 STMicroelectronics - All rights reserved

STMicroelectronics group of companies

Australia - Belgium - Brazil - Canada - China - Czech Republic - Finland - France - Germany - Hong Kong - India - Israel - Italy - Japan - Malaysia - Malta - Morocco - Singapore - Spain - Sweden - Switzerland - United Kingdom - United States of America

www.st.com