

Excellent Integrated System Limited

Stocking Distributor

Click to view price, real time Inventory, Delivery & Lifecycle Information:

[STMicroelectronics](#)

[STT2PF60L](#)

For any questions, you can email us directly:

sales@integrated-circuit.com



STT2PF60L

P-CHANNEL 60V - 0.20Ω - 2A - SOT-23-6L
STripFET™ II Power MOSFET

General features

Type	V _{DSS}	R _{DS(on)}	I _D
STT2PF60L	60V	< 0.25Ω	2A

- Standard outline for easy automated surface mount assembly
- Low threshold drive

Description

This Power MOSFET is the latest development of STMicroelectronics unique “Single Feature Size™” strip-based process. The resulting transistor shows extremely high packing density for low on-resistance, rugged avalanche characteristics and less critical alignment steps therefore a remarkable manufacturing reproducibility.

Applications

- DC motor drive
- DC-DC converters
- Battery management in nomadic equipment
- Power management in portable/desktop PCs
- Cellular



Internal schematic diagram

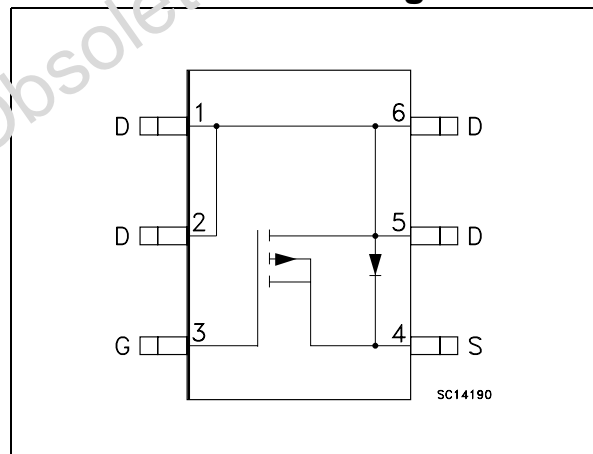

Order codes

Sales Type	Marking	Package	Packaging
STT2PF60L	STP6	SOT23-6L	Tape & Reel

Electrical ratings

STT2PF60L

1 Electrical ratings

Table 1. Absolute maximum ratings

Symbol	Parameter	Value	Unit
V_{DS}	Drain-Source Voltage ($V_{GS} = 0$)	60	V
V_{DGR}	Drain-gate Voltage ($R_{GS} = 20k\Omega$)	60	V
V_{GS}	Gate-Source Voltage	± 15	V
I_D	Drain Current (continuous) at $T_C = 25^\circ C$	2	A
I_D	Drain Current (continuous) at $T_C = 100^\circ C$	1.3	A
$I_{DM}^{(1)}$	Drain Current (pulsed)	8	A
P_{TOT}	Total Dissipation at $T_C = 25^\circ C$	1.6	W

1. Pulse width limited by safe operating area

Table 2. Thermal data

Symbol	Parameter	Value	Unit
$R_{thJ-amb}^{(1)}$	Thermal resistance junction-case Max	78	$^\circ C/W$
T_j	Maximum operating junction temperature	150	$^\circ C$
T_{stg}	Storage temperature	-55 to 150	$^\circ C$

1. Mounted on a 1 in² pad of 2 oz Cu in FR-4 board for t<10sec

Note: For the P-Channel MOSFET actual polarity of voltage and current has to be reverse

STT2PF60L

Electrical characteristics

2 Electrical characteristics

(T_{CASE}=25°C unless otherwise specified)

Table 3. On/off states

Symbol	Parameter	Test Conditions	Min.	Typ.	Max.	Unit
V _{(BR)DSS}	Drain-Source Breakdown Voltage	I _D = 250μA, V _{GS} = 0	60			V
I _{DSS}	Zero Gate Voltage Drain Current (V _{GS} = 0)	V _{DS} = Max Rating, V _{DS} = Max Rating, Tc=125°C			1 10	μA μA
I _{GSS}	Gate Body Leakage Current (V _{DS} = 0)	V _{GS} = ±15V			±100	nA
V _{GS(th)}	Gate Threshold Voltage	V _{DS} = V _{GS} , I _D = 250μA	1			V
R _{DS(on)}	Static Drain-Source On Resistance	V _{GS} = 10V, I _D = 1A V _{GS} = 4.5V, I _D = 1A		0.20 0.24	0.25 0.30	Ω Ω

Table 4. Dynamic

Symbol	Parameter	Test Conditions	Min.	Typ.	Max.	Unit
g _{fs} ⁽¹⁾	Forward Transconductance	V _{DS} = 10V, I _D = 1A		3		S
C _{iss}	Input Capacitance	V _{DS} = 25V, f = 1 MHz, V _{GS} = 0		313		pF
C _{oss}	Output Capacitance			67		pF
C _{rss}	Reverse Transfer Capacitance			25		pF
Q _g	Total Gate Charge	V _{DD} = 30V, I _D = 24A		5	7	nC
Q _{gs}	Gate-Source Charge	V _{GS} = 10V		0.5		nC
Q _{gd}	Gate-Drain Charge	(see Figure 14)		2.2		nC

⁽¹⁾ Pulsed: pulse duration=300μs, duty cycle 1.5%

Note: For the P-Channel MOSFET actual polarity of voltage and current has to be reversed

Electrical characteristics
STT2PF60L
Table 5. Switching times

Symbol	Parameter	Test Conditions	Min.	Typ.	Max.	Unit
$t_{d(on)}$	Turn-on Delay Time	$V_{DD}=30V, I_D=1A,$ $R_G=4.7\Omega, V_{GS}=4.5V$ (see Figure 13)		44		ns
t_r	Rise Time			34		ns
$t_{d(off)}$	Turn-off Delay Time	$V_{DD}=30V, I_D=1A,$ $R_G=4.7\Omega, V_{GS}=4.5V$ (see Figure 13)		42		ns
t_f	Fall Time			15		ns

Table 6. Source drain diode

Symbol	Parameter	Test Conditions	Min.	Typ.	Max.	Unit
I_{SD}	Source-drain Current				2	A
$I_{SDM}^{(1)}$	Source-drain Current (pulsed)				8	A
$V_{SD}^{(2)}$	Forward on Voltage	$I_{SD}=2A, V_{GS}=0$			1.2	V
t_{rr}	Reverse Recovery Time	$I_{SD}=2A, di/dt = 100A/\mu s,$ $V_{DD}=30V, T_j=150^\circ C$		38		ns
Q_{rr}	Reverse Recovery Charge			36.3		nC
I_{RRM}	Reverse Recovery Current			2.5		A

1. Pulse width limited by safe operating area

 2. Pulsed: pulse duration=300 μs , duty cycle 1.5%

Note: For the P-Channel MOSFET actual polarity of voltage and current has to be reversed

STT2PF60L

Electrical characteristics

2.1 Electrical characteristics (curves)

Figure 1. Safe operating area

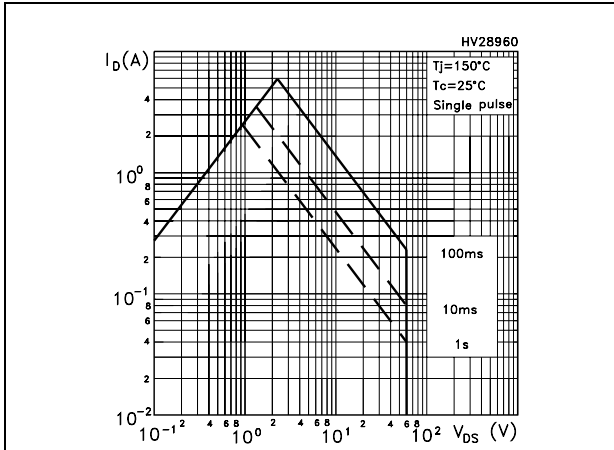

Figure 2. Thermal impedance

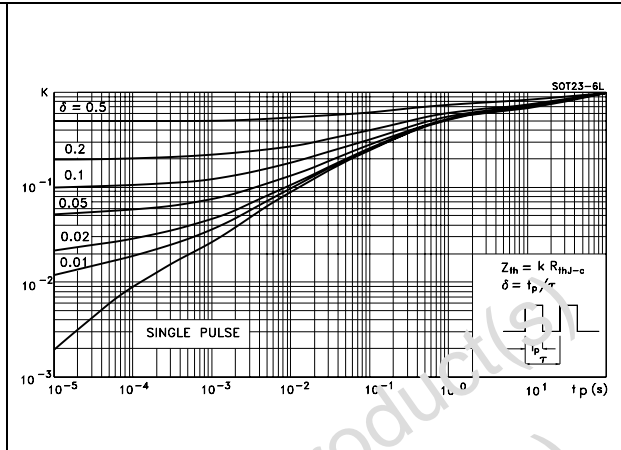

Figure 3. Output characteristics

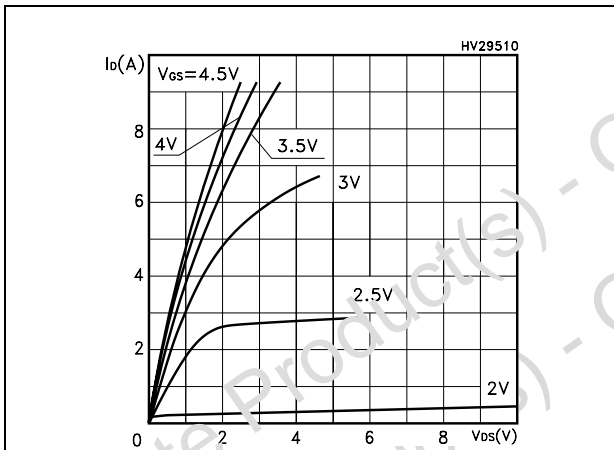

Figure 4. Transfer characteristics

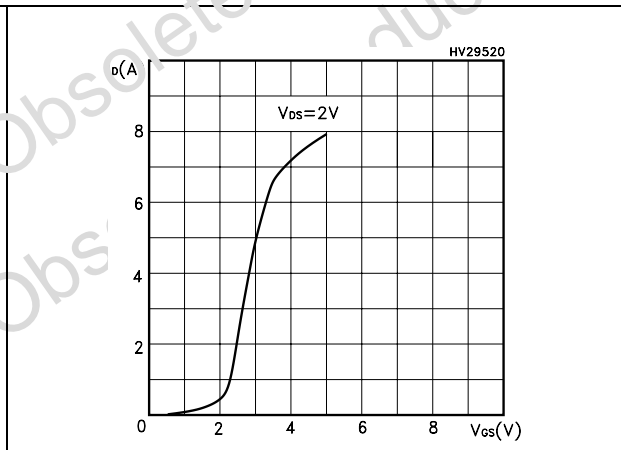

Figure 5. Transconductance

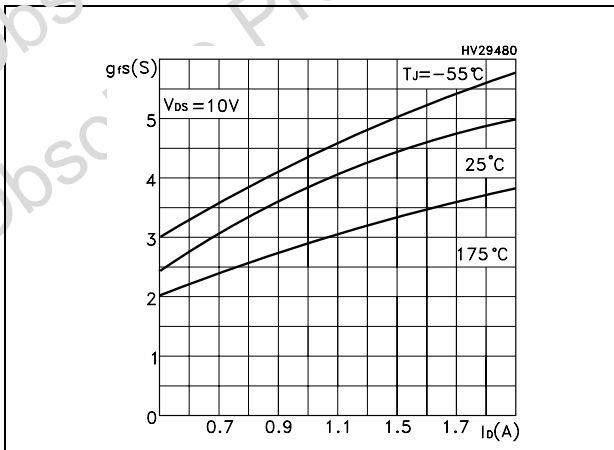
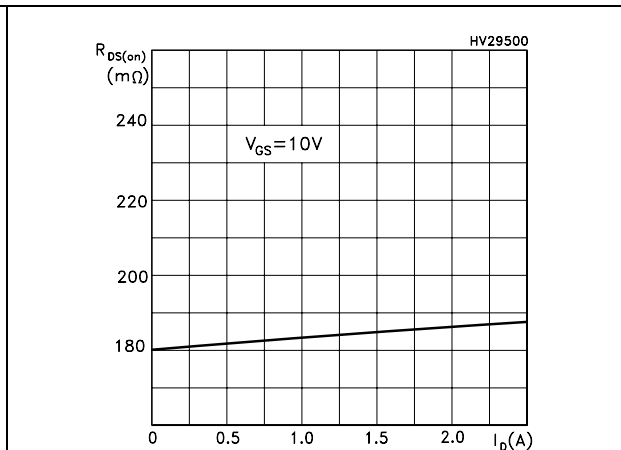

Figure 6. Static drain-source on resistance



Electrical characteristics

STT2PF60L

Figure 7. Gate charge vs gate-source voltage **Figure 8. Capacitance variations**

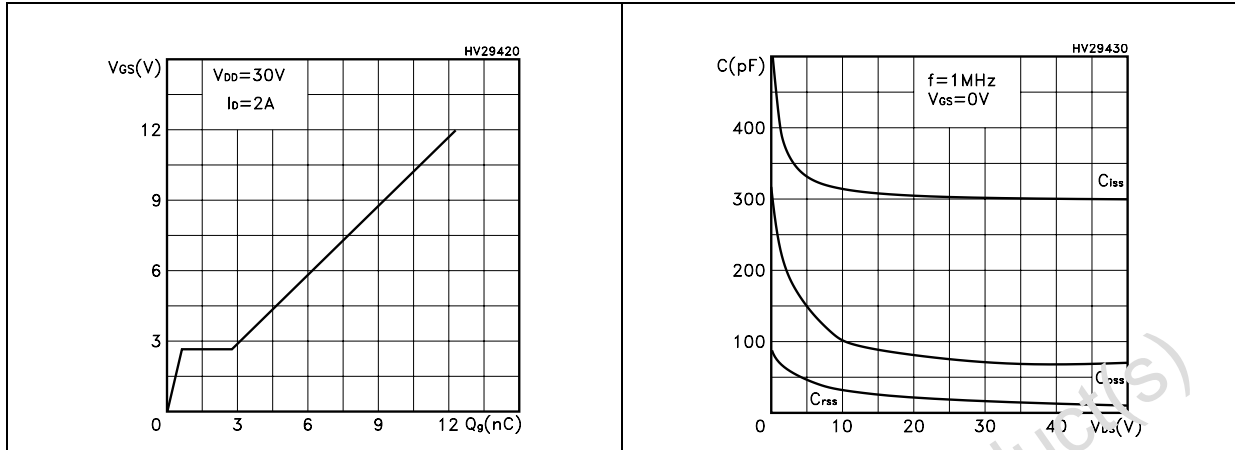

Figure 9. Normalized gate threshold voltage vs temperature **Figure 10. Normalized on-resistance vs temperature**

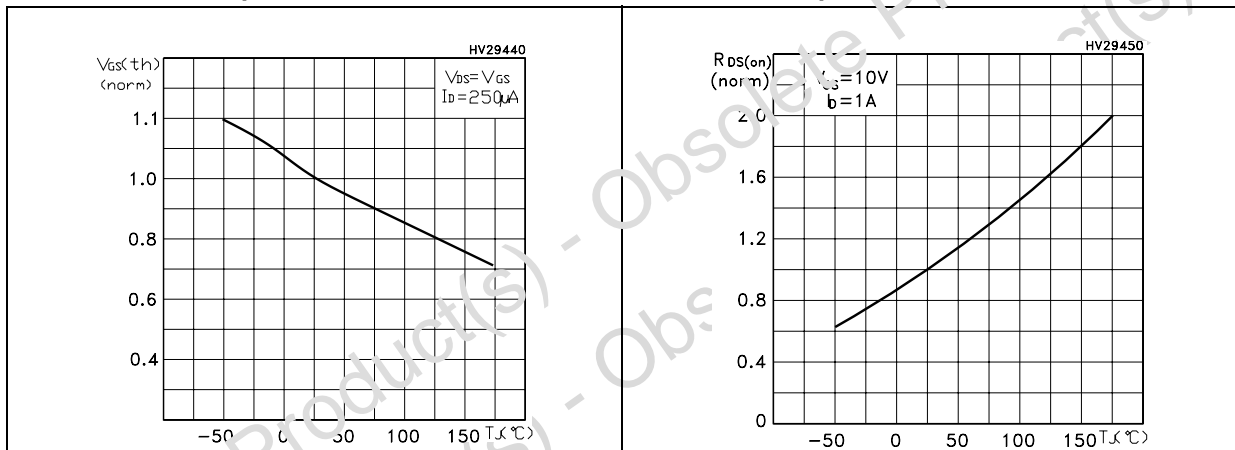
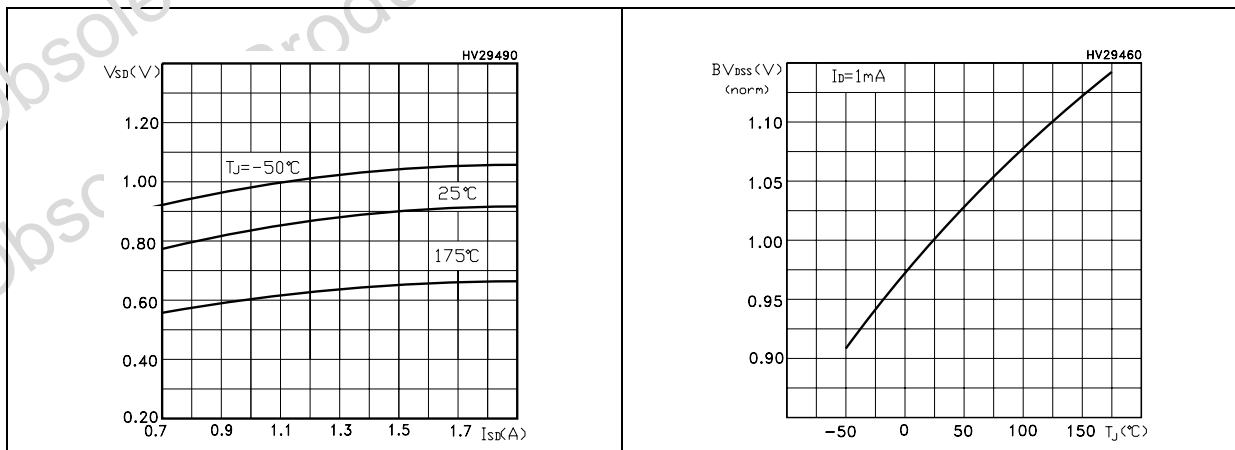

Figure 11. Source-drain diode forward characteristics **Figure 12. Normalized $B_{V_{DSS}}$ vs temperature**



3 Test circuit

Figure 13. Switching times test circuit for resistive load

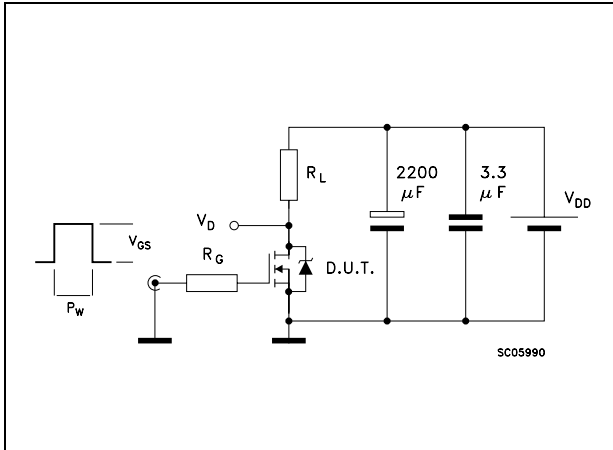

Figure 14. Gate charge test circuit

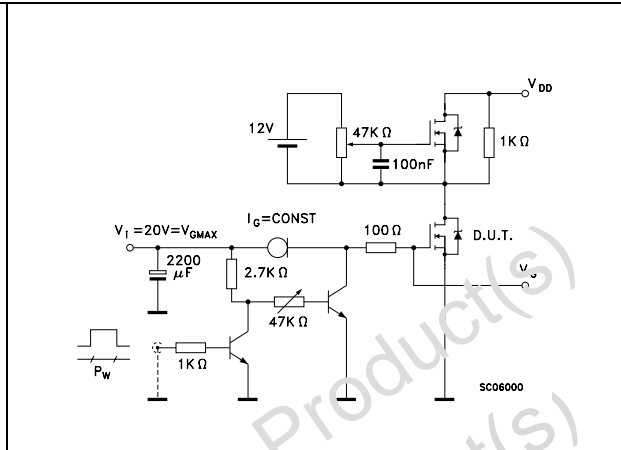

Figure 15. Test circuit for inductive load switching and diode recovery times

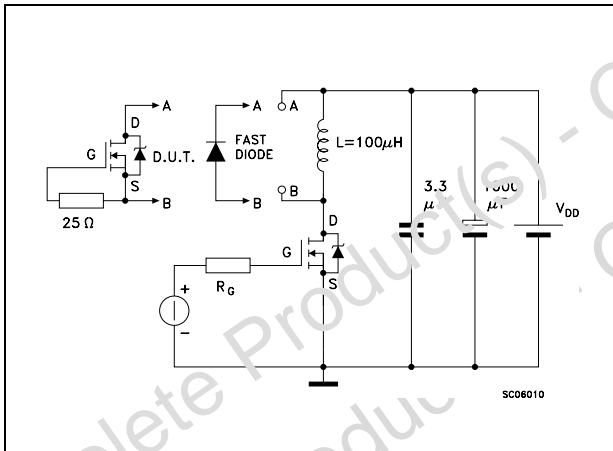

Figure 16. Unclamped Inductive load test circuit

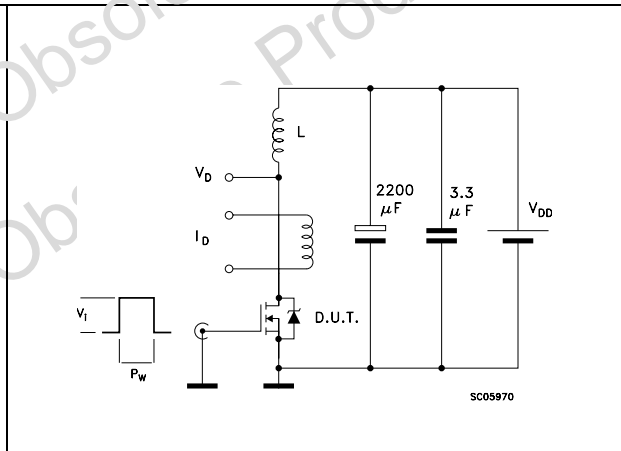
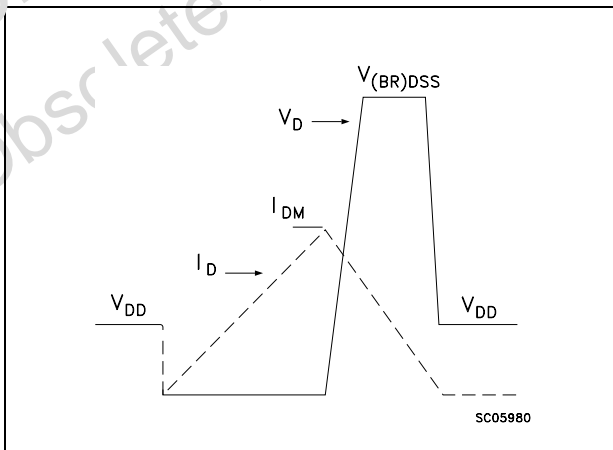

Figure 17. Unclamped inductive waveform



4 Package mechanical data

In order to meet environmental requirements, ST offers these devices in ECOPACK® packages. These packages have a Lead-free second level interconnect . The category of second level interconnect is marked on the package and on the inner box label, in compliance with JEDEC Standard JESD97. The maximum ratings related to soldering conditions are also marked on the inner box label. ECOPACK is an ST trademark. ECOPACK specifications are available at: www.st.com

Obsolete Product(s) - Obsolete Product(s)
Obsolete Product(s) - Obsolete Product(s)

STT2PF60L

Package mechanical data

TSOP-6 MECHANICAL DATA

DIM.	mm			mils		
	MIN.	TYP.	MAX.	MIN.	TYP.	MAX.
A	0.90		1.45	0.035		0.057
A1	0.00		0.15	0.000		0.006
A2	0.90		1.30	0.035		0.051
b	0.25		0.50	0.010		0.020
C	0.09		0.20	0.004		0.008
D	2.80		3.10	0.110		0.122
E	2.60		3.00	0.102		0.118
E1	1.50		1.75	0.059		0.069
L	0.35		0.55	0.014		0.022
e		0.95			0.037	
e1		1.90			0.075	

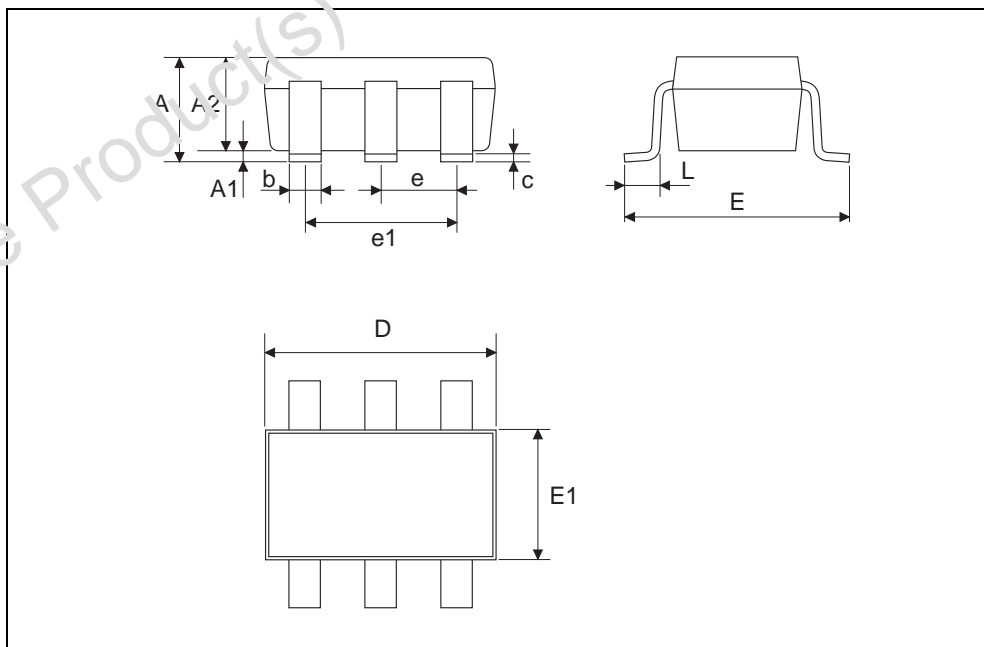

5 Revision history

Table 7. Document revision history

Date	Revision	Changes
07-May-2002	1	Initial release.
19-Apr-2003	2	Preliminary version
22-Dec-2005	3	Final version

Obsolete Product(s) - Obsolete Product(s)
Obsolete Product(s) - Obsolete Product(s)

STT2PF60L

Revision history

Information furnished is believed to be accurate and reliable. However, STMicroelectronics assumes no responsibility for the consequences of use of such information nor for any infringement of patents or other rights of third parties which may result from its use. No license is granted by implication or otherwise under any patent or patent rights of STMicroelectronics. Specifications mentioned in this publication are subject to change without notice. This publication supersedes and replaces all information previously supplied. STMicroelectronics products are not authorized for use as critical components in life support devices or systems without express written approval of STMicroelectronics.

The ST logo is a registered trademark of STMicroelectronics.
All other names are the property of their respective owners

© 2005 STMicroelectronics - All rights reserved

STMicroelectronics group of companies

Australia - Belgium - Brazil - Canada - China - Czech Republic - Finland - France - Germany - Hong Kong - India - Israel - Italy - Japan - Malaysia - Malta - Morocco - Singapore - Spain - Sweden - Switzerland - United Kingdom - United States of America

www.st.com