

## Excellent Integrated System Limited

Stocking Distributor

Click to view price, real time Inventory, Delivery & Lifecycle Information:

[STMicroelectronics](#)

[STTA312B](#)

For any questions, you can email us directly:

[sales@integrated-circuit.com](mailto:sales@integrated-circuit.com)



# STTA312B

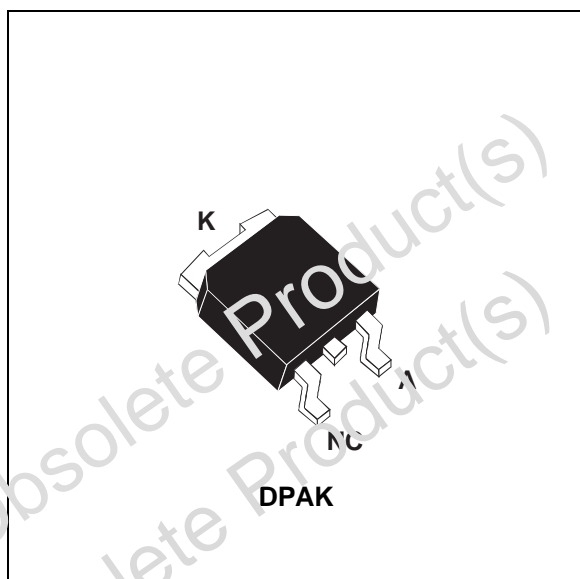
## TURBOSWITCH™ ULTRA-FAST HIGH VOLTAGE DIODE

### MAIN PRODUCT CHARACTERISTICS

<b>I<sub>F(AV)</sub></b>	<b>3 A</b>
<b>V<sub>RRM</sub></b>	<b>1200 V</b>
<b>t<sub>rr (typ)</sub></b>	<b>65 ns</b>
<b>V<sub>F (max)</sub></b>	<b>1.7 V</b>

### FEATURES AND BENEFITS

- SPECIFIC TO THE FOLLOWING OPERATIONS :  
SNUBBING OR CLAMPING, DEMAGNETIZATION AND RECTIFICATION
- ULTRA-FAST, SOFT RECOVERY
- VERY LOW OVERALL POWER LOSSES AND PARTICULARLY LOW FORWARD VOLTAGE
- HIGH FREQUENCY OPERATION
- HIGH REVERSE VOLTAGE CAPABILITY



### DESCRIPTION

TURBOSWITCH 1200V drastically cuts losses in all high voltage operations which require extremely fast, soft and noise-free power diodes.

Due to their optimized switching performances they also highly decrease power losses in any associated switching IGBT or MOSFET in all "freewheel mode" operations

They are particularly suitable in motor control circuitries, or in primary of SMPS as snubber, clamping or demagnetizing diodes. They are also suitable for the secondary of SMPS as high voltage rectifier diodes.

### ABSOLUTE RATINGS (limiting values)

Symbol	Parameter		Value	Unit
V <sub>RRM</sub>	Repetitive peak reverse voltage		1200	V
V <sub>RSM</sub>	Non repetitive peak reverse voltage		1200	V
I <sub>F(RMS)</sub>	RMS forward current		6	A
I <sub>FRM</sub>	Repetitive peak forward current	tp = 5 μs F = 5kHz square	35	A
I <sub>FSM</sub>	Surge non repetitive forward current	tp = 10ms sinusoidal	25	A
T <sub>stg</sub>	Storage temperature range		- 65 to + 150	°C
T <sub>j</sub>	Maximum operating junction temperature		125	°C

**STTA312B**
**THERMAL AND POWER DATA**

Symbol	Parameter	Tests conditions	Value	Unit
$R_{th(j-c)}$	Junction to case thermal resistance		6.5	°C/W
$P_1$	Conduction power dissipation	$I_{F(AV)} = 3A, \delta = 0.5$ $T_c = 80^\circ C$	6.7	W
$P_{max}$	Total power dissipation $P_{max} = P_1 + P_3$ ( $P_3 = 10\% P_1$ )	$T_c = 76^\circ C$	7.5	W

**STATIC ELECTRICAL CHARACTERISTICS**

Symbol	Parameter	Tests conditions	Min.	Typ.	Max.	Unit
$V_F^{**}$	Forward voltage drop	$I_F = 3A$ $T_j = 25^\circ C$			1.8	V
		$I_F = 3A$ $T_j = 125^\circ C$		1.15	1.7	
$I_R^*$	Reverse leakage current	$V_R = 0.8$ $\times V_{RRM}$	$T_j = 25^\circ C$		20	$\mu A$
			$T_j = 125^\circ C$		150	400
$V_{to}$	Threshold voltage	$I_p < 3.I_{AV}$	$T_j = 125^\circ C$		1.15	V
$r_d$	Dynamic resistance				185	m $\Omega$

 Test pulses : \*  $t_p = 380 \mu s, \delta < 2\%$ 

 \*\*  $t_p = 5 ms, \delta < 2\%$ 

To evaluate the maximum conduction losses use the following equation :

$$P = V_{to} \times I_{F(AV)} + r_d \times I_F^2 (RMS)$$

**DYNAMIC ELECTRICAL CHARACTERISTICS**
**TURN-OFF SWITCHING**

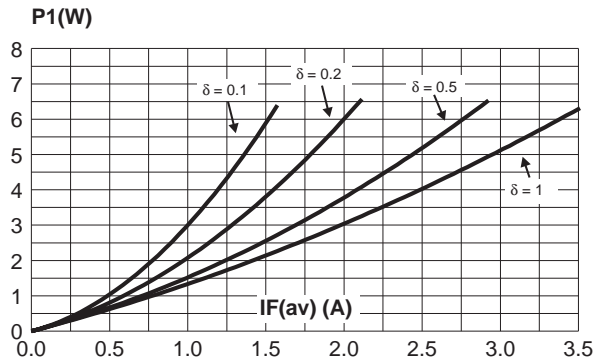
Symbol	Parameter	Test conditions	Min.	Typ.	Max.	Unit
$t_{rr}$		$T_j = 25^\circ C$ $I_F = 0.5A$ $I_R = 1A$ $I_{rr} = 0.25A$ $I_F = 1A$ $di_F/dt = 50A/\mu s$ $V_R = 30V$		65	115	ns
$I_{RM}$	Maximum recovery current	$T_j = 125^\circ C$ $I_F = 3A$ $V_R = 600V$ $di_F/dt = -16A/\mu s$ $di_F/dt = -50A/\mu s$		6.0	3.6	A
S factor	Softness factor	$T_j = 125^\circ C$ $V_R = 600V$ $I_F = 3A$ $di_F/dt = -50A/\mu s$		1.2		-

**TURN-ON SWITCHING**

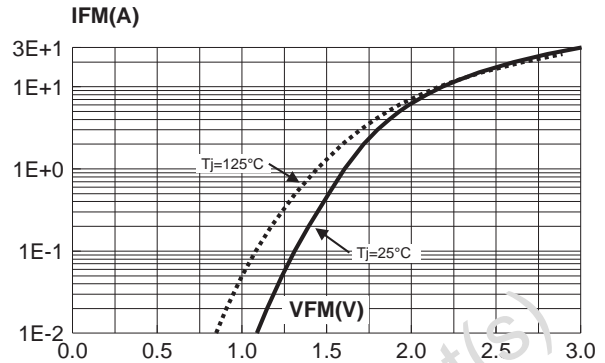
Symbol	Parameter	Test conditions	Min.	Typ.	Max.	Unit
$t_{fr}$	Forward recovery time	$T_j = 25^\circ C$ $I_F = 3A$ $di_F/dt = 16A/\mu s$			900	ns
$V_{FP}$	Peak forward voltage	Measured at $1.1 \times V_{Fmax}$			35	V

**STTA312B**

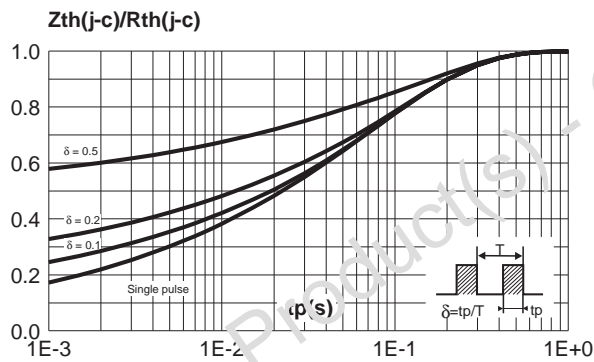
**Fig. 1:** Conduction losses versus average current.



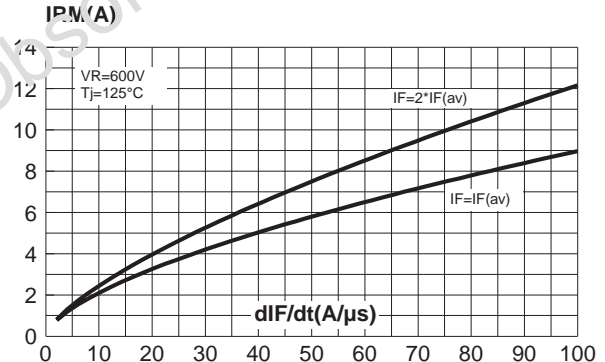
**Fig. 2:** Forward voltage drop versus forward current (maximum values).



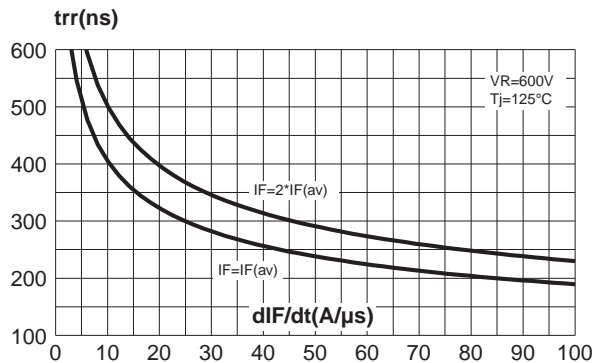
**Fig. 3:** Relative variation of thermal impedance junction to case versus pulse duration.



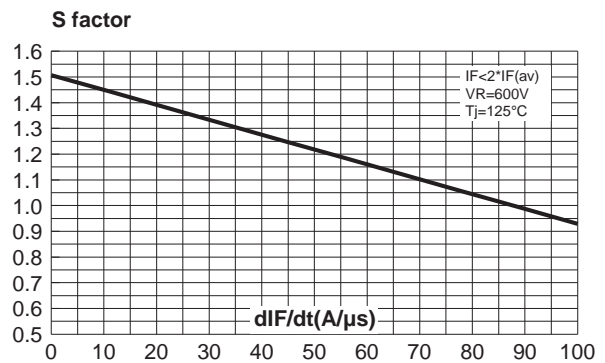
**Fig. 4:** Peak reverse recovery current versus  $dI_F/dt$  (90% confidence).



**Fig. 5:** Reverse recovery time versus  $dI_F/dt$  (90% confidence).

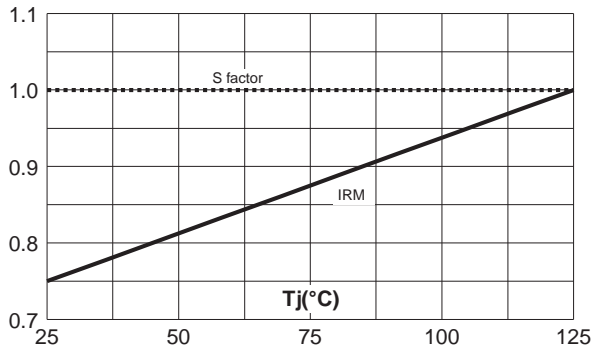


**Fig. 6:** Softness factor  $t_b/t_a$  versus  $dI_F/dt$  (typical values).

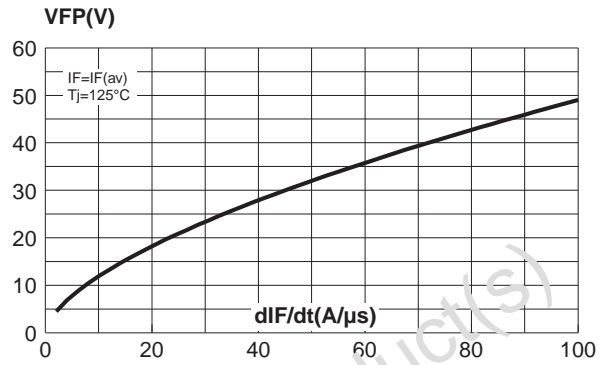


**STTA312B**

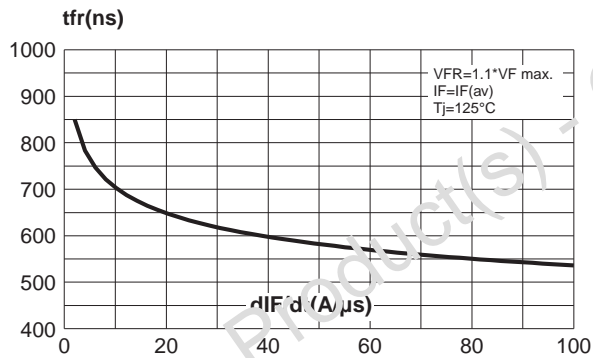
**Fig. 7:** Relative variation of dynamic parameters versus junction temperature (reference:  $T_j=125^\circ\text{C}$ ).



**Fig. 8:** Transient peak forward voltage versus  $dI_F/dt$  (90% confidence).



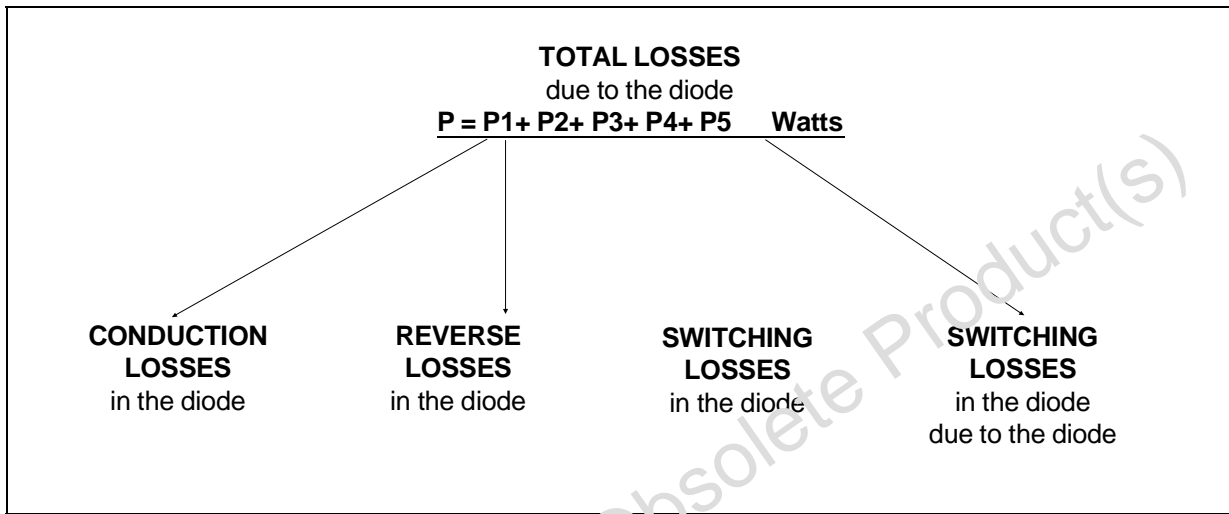
**Fig. 9:** Forward recovery time versus  $dI_F/dt$  (90% confidence).



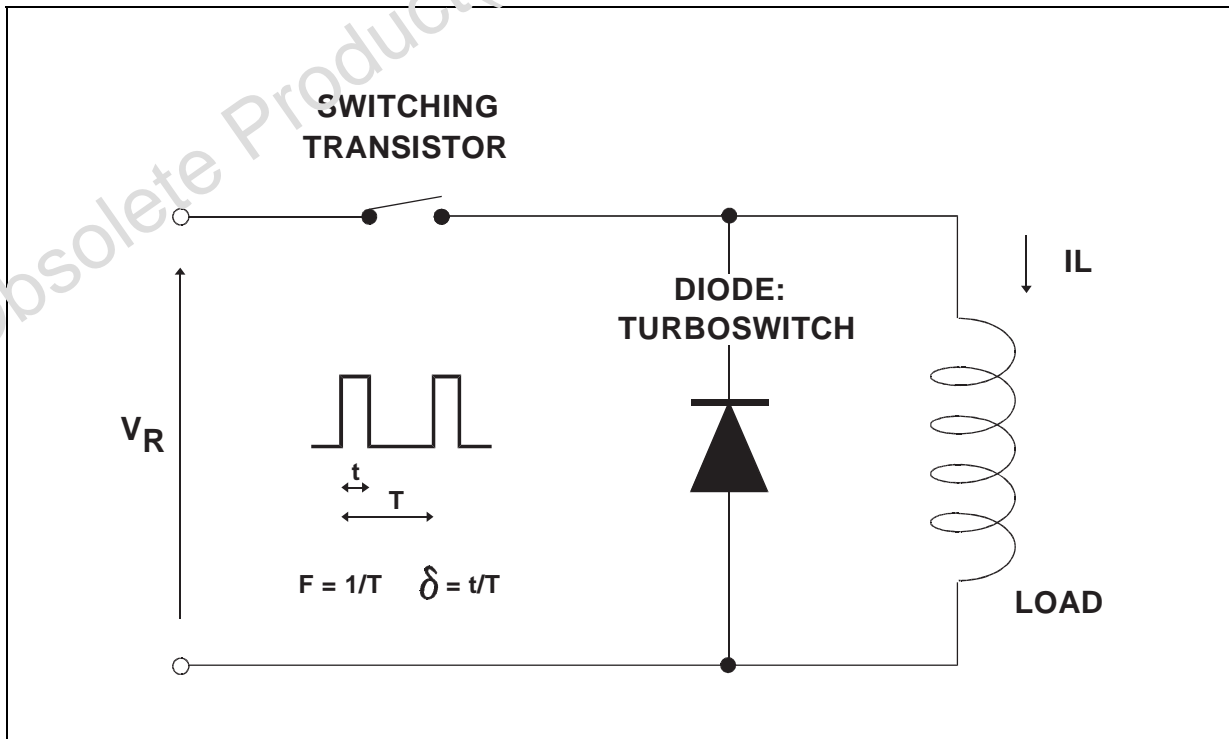
**APPLICATION DATA**

The 1200V TURBOSWITCH™ series has been designed to provide the lowest overall power losses in all frequency or high pulsed current operations.

In such application (fig. A to D), the way of calculating the power losses is given below :



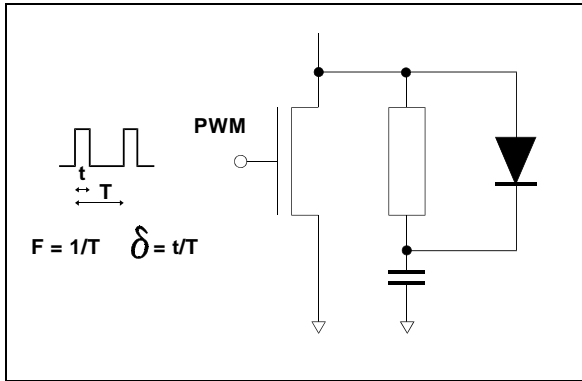
**Fig. A : "FREEWHEEL MODE".**



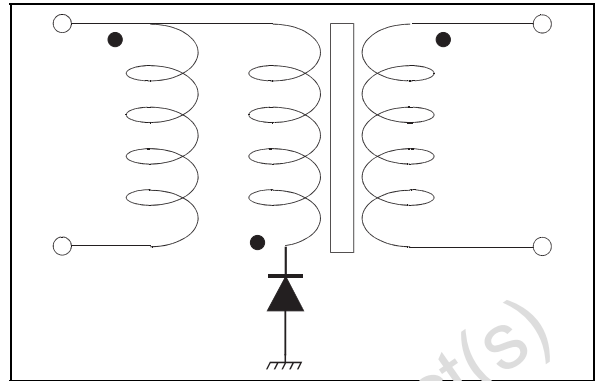
**STTA312B**

**APPLICATION DATA (Cont'd)**

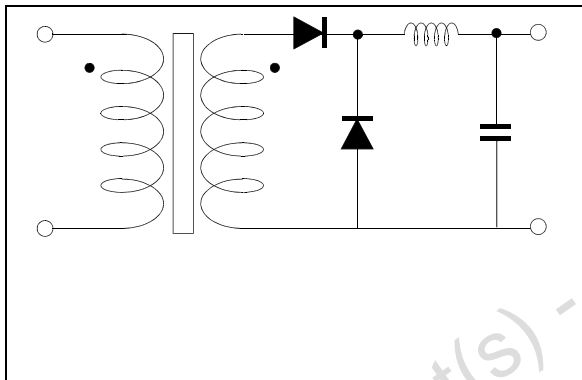
**Fig. B : SNUBBER DIODE.**



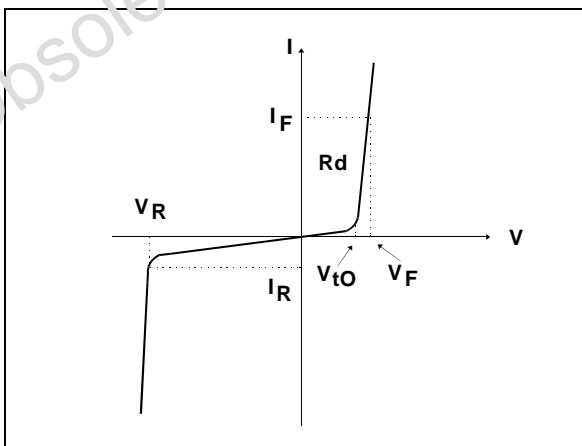
**Fig. C : DEMAGNETIZING DIODE.**



**Fig. D : RECTIFIER DIODE.**



**Fig. E : STATIC CHARACTERISTICS.**



**Conduction losses :**

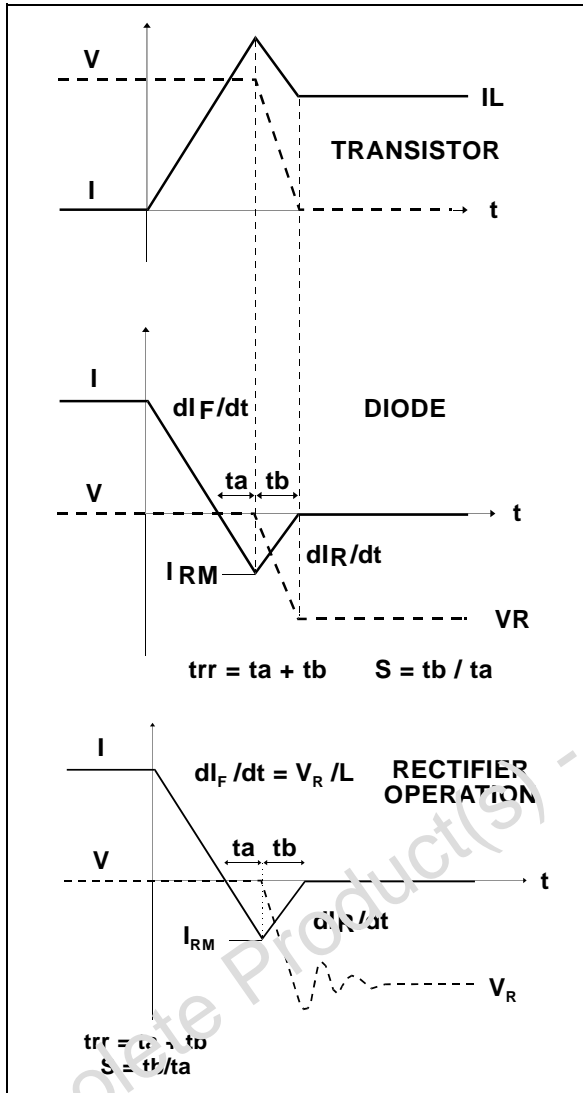
$$P1 = V_{t0} \times I_{F(AV)} + R_d \times I_{F(RMS)}^2$$

**Reverse losses :**

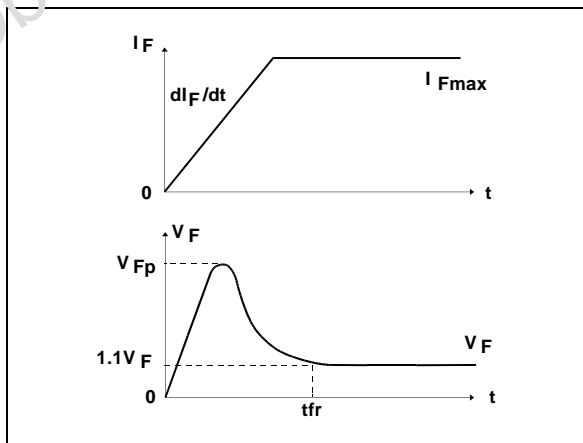
$$P2 = V_R \times I_R \times (1 - \delta)$$

**APPLICATION DATA (Cont'd)**

**Fig. F : TURN-OFF CHARACTERISTICS.**



**Fig. G : TURN-ON CHARACTERISTICS.**



**Turn-on losses :**  
(in the transistor, due to the diode)

$$P5 = \frac{V_R \times I_{RM}^2 \times (3+2 \times S) F}{6 \times dI_F/dt} + \frac{V_R \times I_{RM} \times I_L \times (S+2) \times F}{2 \times dI_F/dt}$$

**Turn-off losses :**

$$P3 = \frac{V_R \times I_{RM}^2 \times S \times F}{6 \times dI_F/dt}$$

**Turn-off losses :**  
with non negligible serial inductance

$$P3' = \frac{V_R \times I_{RM}^2 \times S \times F \times L \times I_{RM}^2 \times F}{6 \times dI_F/dt + 2}$$

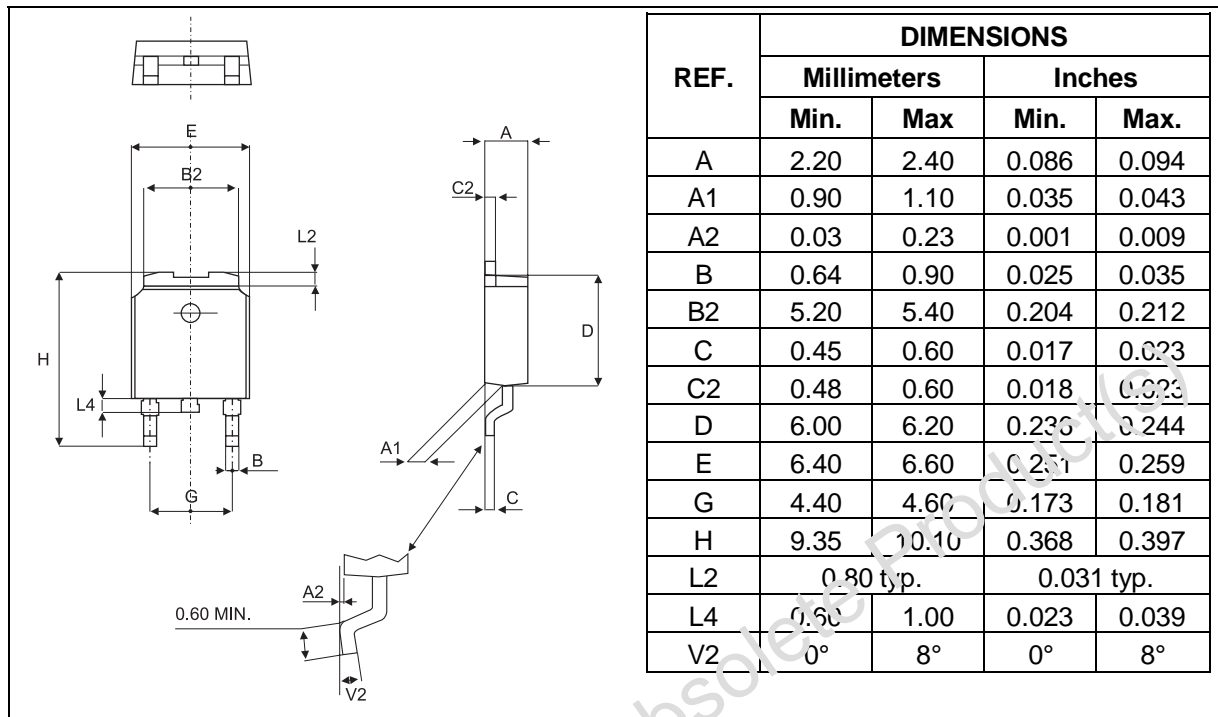
P3, P3' and P5 are suitable for power MOSFET and IGBT

**Turn-on losses :**  
 $P4 = 0.4 (V_{FP} - V_F) \times I_{Fmax} \times t_{fr} \times F$

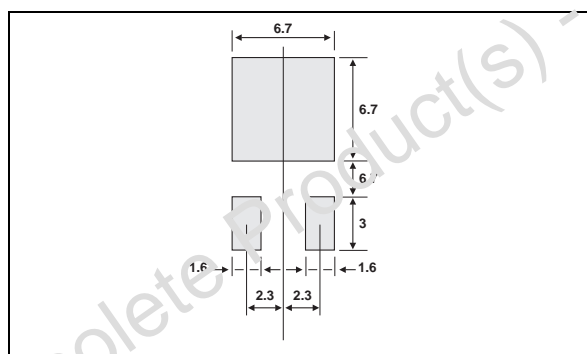


### STTA312B

#### PACKAGE MECHANICAL DATA DPAK



#### FOOTPRINT DIMENSIONS (in millimeters)



Ordering type	Marking	Package	Weight	Base qty	Delivery mode
STTA312B	A312	DPAK	0.3g	75	Tube
STTA312B-TR	A312	DPAK	0.3g	2500	Tape & reel

■ Epoxy meets UL94,V0

Information furnished is believed to be accurate and reliable. However, STMicroelectronics assumes no responsibility for the consequences of use of such information nor for any infringement of patents or other rights of third parties which may result from its use. No license is granted by implication or otherwise under any patent or patent rights of STMicroelectronics. Specifications mentioned in this publication are subject to change without notice. This publication supersedes and replaces all information previously supplied. STMicroelectronics products are not authorized for use as critical components in life support devices or systems without express written approval of STMicroelectronics.

The ST logo is a registered trademark of STMicroelectronics

© 1999 STMicroelectronics - Printed in Italy - All rights reserved.

STMicroelectronics GROUP OF COMPANIES

Australia - Brazil - China - Finland - France - Germany - Hong Kong - India - Italy - Japan - Malaysia  
Malta - Morocco - Singapore - Spain - Sweden - Switzerland - United Kingdom - U.S.A.

<http://www.st.com>