

Excellent Integrated System Limited

Stocking Distributor

Click to view price, real time Inventory, Delivery & Lifecycle Information:

[3M](#)

[3443-63](#)

For any questions, you can email us directly:

sales@integrated-circuit.com

3M™ Locator Plate 3443-63

Instructions for the Assembly of 3M™ High-Speed Card-Edge Connector

1.0 General

3M manual and pneumatic assembly presses and accessory assembly equipment are recommended for the termination of 3M High-Speed Card-Edge Connectors. 3M Assembly Equipment is offered to reduce set-up time, to provide easy and fast assembly, and to reduce assembly error. The 3M Locator Plate 3443-63 is designed to assemble all 3M High-Speed Card-Edge Connectors.

Number of Contacts	Connector Part Number	Keying Plug Number	Strain Relief Number	Locator Plate Number 3443	Platen Plate Number 3442	Shut Height Adjustment for 3M Assembly Presses		
						3640	3335 3316	3830
10	3358	3439-2	3448-52	-63	-30	18 1/2	19	*See below
16	3368		3448-53					
20	3461		3448-54					
26	3462		3448-55					
34	3463		3448-56					
40	3464		3448-57					
50	3415		3448-58					
60	3666		3448-31					
64	3403		3448-59					

*The 3M™ Pneumatic Press Shut Height 3830 is self adjusting. See the instructions for the Pneumatic Press.

3M™ Locator Plate 3443-63

2.0 Procedures for Set Up

Adjustments to the connector guides are required for the set-up relative to style and length of the 3M™ High-Speed Card-Edge Connector.

- 2.1 Position connector guides for the appropriate number of contacts in the connector. Numbers are found at both ends of the guides. Align both guide notches with the proper position number. Lift and rotate the connector guides as necessary to obtain proper alignment. (Figure 1)
- 2.2 Install the locator plate on the press table over the mounting studs.

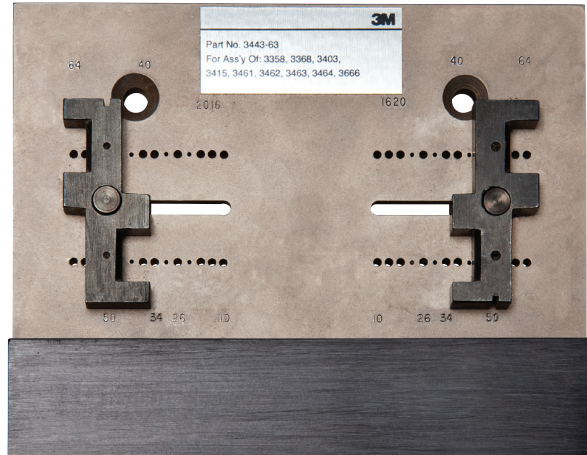

Figure 1

3.0 Procedures for Adjusting Shut Height

The shut height setting is referenced in the chart on page one.

- 3.1 The shut height adjustment is made from the base of the assembly press without the locator plate in place.
- 3.2 Place the shut height gauge, #3436-1J, across the press base. (See Figures 2 and 3)
- 3.3 Lower the handle of the press until the handle casting makes contact with the press casting. (See Figure 2)

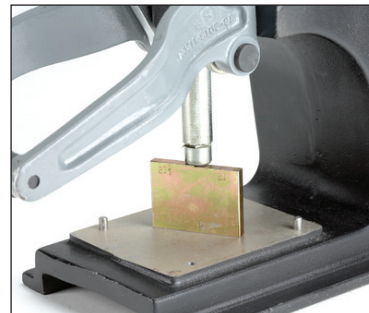

Figure 2

3M™ Locator Plate 3443-63

- 3.4 Rotate the shut height adjustment feature until the bottom of the shaft contacts the desire position on the gauge. (See Figure 3 and 4)
- 3.5 Install the locator plate and the appropriate platen on the press. The platen should be positioned parallel with the connector body and cover.

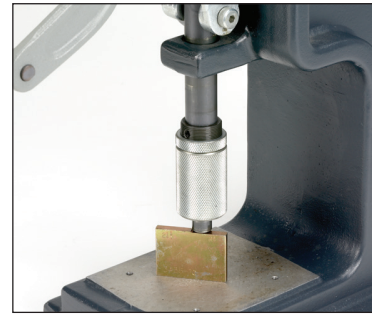

Figure 3



Figure 4

4.0 Procedures for Connector/Cable Assembly

- 4.1 Replace the platen in parallel alignment with the connector body. Refer to the table on page one for proper platen.
- 4.2 Rub thumb along the length of paper liner to insure maximum adhesive transfer to the cover; then remove liner.
- 4.3 Press cable ribs into cover alignment grooves.
- 4.4
 1. Visually inspect to insure that:
 - a. Cable is properly aligned and oriented in cover grooves.
 - b. Cable end is flush with cover for end terminations, or perpendicular to cover for mid-span terminations.
 2. Position the 3M™ High-Speed Card-Edge Connector body in the locator plate, contacts up. Orient the connector for pin #1 to conductor #1 assembly.
 3. Place the cable/cover sub-assembly over the connector body, inserting cover clips into body ports.
 4. Lower the assembly press handle fully to complete the connection.
 5. Raise the handle and remove the completed assembly.
 6. Visually inspect to insure that:
 - a. Cover is fully seated and parallel to the body.
 - b. Cover retaining device is fully engaged with the body.

3M™ Locator Plate 3443-63

5.0 Polarizing: 3M™ Polarizing Key 3439-2

- 5.1 Insert polarizing key (Figure 5) into desired key slot in connector, pushing until key bottoms in connector. Some resistance will be felt as the edge find of the key meet the connector.
- 5.2 Gently bend tab back and forth to break away from polarizing key.
- 5.3 Cut slot in printed circuit board “tongue” to correspond with polarizing key position.



Figure 5

6.0 Strain Relief Attachment

- 6.1 Fold cable back over cover.
- 6.2 Engage one end of strain relief into strain relief retainer slot (2-piece strain relief).
- 6.3 Push down on opposite end until strain relief snaps into place. (Figure 6)

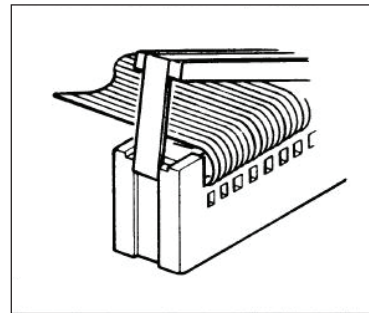

Figure 6

7.0 Pull Tab Attachment

- 7.1 Insert Pull Tab beneath the strain relief. Remove protective liner.
- 7.2 Bring ends together to form circular or tear-drop shape. (Figure 7 & 8)

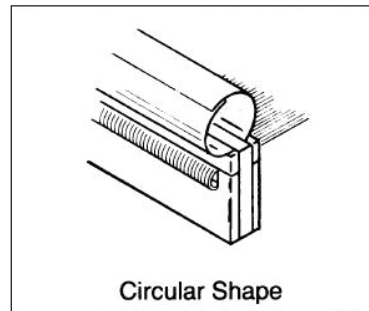

Figure 7

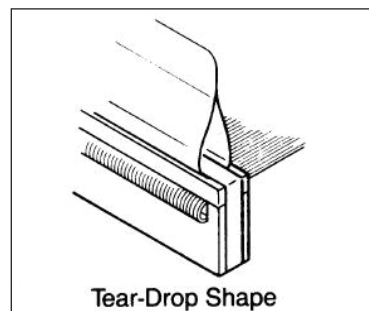

Figure 8

Customer and Technical Service

Within the U.S.:

Customer Service: 800-225-5373

Technical Support: 512-984-6703

Outside of the U.S.:

For customer service and technical support, please contact your local 3M Electronic Solutions Division representative.

3M is a trademark of 3M Company.

Important Notice

PRODUCT USE: All statements, technical information and recommendations contained in this document are based upon tests or experience that 3M believes are reliable. However, many factors beyond 3M's control can affect the use and performance of a 3M product in a particular application, including the conditions under which the product is used and the time and environmental conditions in which the product is expected to perform. Since these factors are uniquely within the user's knowledge and control, it is essential that the user evaluate the 3M product to determine whether it is fit for a particular purpose and suitable for the user's application.

Warranty; Limited Remedy; Limited Liability.

3M's product warranty is stated in its Product Literature available upon request. **3M MAKES NO OTHER WARRANTIES INCLUDING, BUT NOT LIMITED TO, ANY IMPLIED WARRANTY OF MERCHANTABILITY OR FITNESS FOR A PARTICULAR PURPOSE.** If this product is defective within the warranty period stated above, your exclusive remedy shall be, at 3M's option, to replace or repair the 3M product or refund the purchase price of the 3M product. **Except where prohibited by law, 3M will not be liable for any indirect, special, incidental or consequential loss or damage arising from this 3M product, regardless of the legal theory asserted.**



Electronic Solutions Division Interconnect Products

6801 River Place Blvd.
Austin, TX 78726-9000
800-225-5373
www.3Mconnectors.com

Please recycle. Printed in USA.
© 3M 2014. All rights reserved.
78-9101-4627-9