

Excellent Integrated System Limited

Stocking Distributor

Click to view price, real time Inventory, Delivery & Lifecycle Information:

[STMicroelectronics](#)

[STD4NK50ZD](#)

For any questions, you can email us directly:

sales@integrated-circuit.com



STD4NK50ZD - STD4NK50ZD-1 STF4NK50ZD - STP4NK50ZD

N-channel 500V - 2.4Ω - 3A - TO-220 - TO-220FP- DPAK - IPAK
 Fast diode SuperMESH™ Power MOSFET

General features

Type	V _{DSS}	R _{DS(on)}	I _D	P _w
STD4NK50ZD-1	500V	<2.7Ω	3A	45W
STD4NK50ZD	500V	<2.7Ω	3A	45W
STF4NK50ZD	500V	<2.7Ω	3A	20W
STP4NK50ZD	500V	<2.7Ω	3A	45W

- 100% avalanche tested
- Extremely high dv/dt capability
- Gate charge minimized
- Very low intrinsic capacitances
- Very good manufacturing repeability

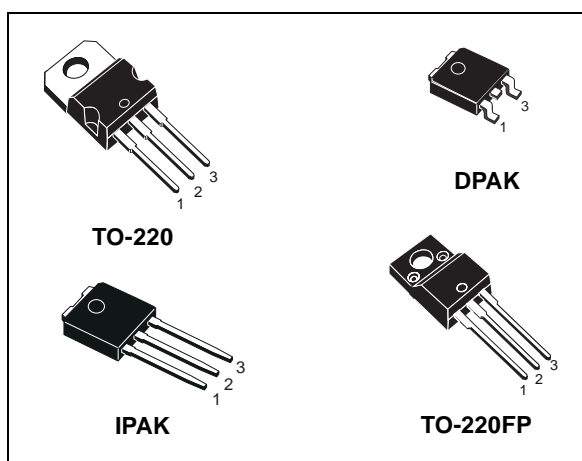

Description

The fast SuperMESH™ series associates all advantages of reduced on-resistance, zener gate protection and outstanding dc/dt capability with a Fast body-drain recovery diode. Such series complements the FDmesh™ advanced technology.

Applications

- Switching application

Internal schematic diagram

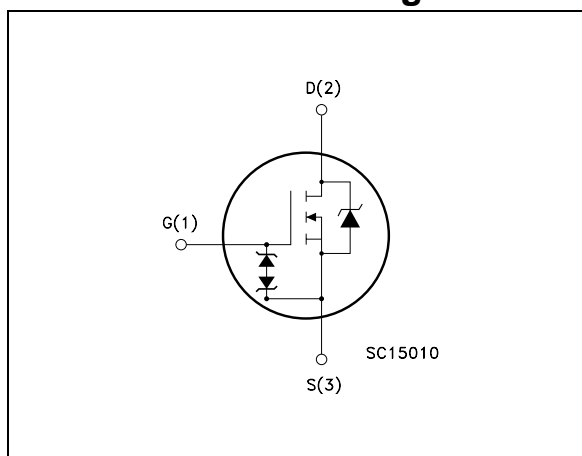

Order codes

Part number	Marking	Package	Packaging
STD4NK50ZD-1	D4NK50ZD-1	IPAK	Tube
STD4NK50ZD	D4NK50ZD	DPAK	Tape & reel
STF4NK50ZD	F4NK50ZD	TO-220FP	Tube
STP4NK50ZD	P4NK50ZD	TO-220	Tube

Contents

1	Electrical ratings	3
2	Electrical characteristics	5
2.1	Electrical characteristics (curves)	6
3	Test circuit	10
4	Package mechanical data	11
5	Packaging mechanical data	16
6	Revision history	17

STD4NK50ZD - STD4NK50ZD-1 - STF4NK50ZD - STP4NK50ZD

Electrical ratings

1 Electrical ratings

Table 1. Absolute maximum ratings

Symbol	Parameter	Value			Unit
		TO-220	IPAK/DPAK	TO-220FP	
V_{DS}	Drain-source voltage ($V_{GS} = 0$)	500			V
V_{DGR}	Drain-gate voltage ($R_{GS} = 20K\Omega$)	500			V
V_{GS}	Gate-source voltage	± 30			V
I_D	Drain current (continuous) at $T_C = 25^\circ C$	3	3 ⁽¹⁾	3 ⁽¹⁾	A
I_D	Drain current (continuous) at $T_C = 100^\circ C$	1.9	1.9 ⁽¹⁾	1.9 ⁽¹⁾	A
$I_{DM}^{(2)}$	Drain current (pulsed)	12	12 ⁽¹⁾	12 ⁽¹⁾	A
P_{TOT}	Total dissipation at $T_C = 25^\circ C$	45		20	W
	Derating factor	0.36		0.16	W/°C
$V_{ESD(G-D)}$	Gate source ESD(HBM-C=100pF, R=1.5KΩ)	2800			V
$dv/dt^{(3)}$	Peak diode recovery voltage slope	15			V/ns
V_{ISO}	Insulation withstand voltage (DC)	--	--	2500	V
T_J T_{stg}	Operating junction temperature Storage temperature	-55 to 150			°C

1. Limited only by maximum temperature allowed
2. Pulse width limited by safe operating area
3. $I_{SD} \leq 3A$, $di/dt \leq 200A/\mu s$, $V_{DD} = 80\%V_{(BR)DSS}$

Table 2. Thermal resistance

Symbol	Parameter	Value			Unit
		TO-220	IPAK/DPAK	TO-220FP	
$R_{thj-case}$	Thermal resistance junction-case Max	2.78		6.25	°C/W
R_{thj-a}	Thermal resistance junction-ambient Max	62.5	100	62.5	°C/W
T_I	Maximum lead temperature for soldering purpose	300			°C

Table 3. Avalanche data

Symbol	Parameter	Value	Unit
I_{AR}	Avalanche current, repetitive or not-repetitive (pulse width limited by T_J Max)	3	A
E_{AS}	Single pulse avalanche energy (starting $T_J = 25^\circ C$, $I_d = I_{AR}$, $V_{DD} = 50V$)	120	mJ

Electrical characteristics

STD4NK50ZD - STD4NK50ZD-1 - STF4NK50ZD - STP4NK50ZD

2 Electrical characteristics

(T_{CASE}=25°C unless otherwise specified)

Table 4. On/off states

Symbol	Parameter	Test conditions	Min.	Typ.	Max.	Unit
V _{(BR)DSS}	Drain-source breakdown voltage	I _D = 1mA, V _{GS} = 0	500			V
I _{DSS}	Zero gate voltage drain current (V _{GS} = 0)	V _{DS} = Max rating, V _{DS} = Max rating @ 125°C			1 50	μA μA
I _{GSS}	Gate body leakage current (V _{DS} = 0)	V _{GS} = ±20V			±10	μA
V _{GS(th)}	Gate threshold voltage	V _{DS} = V _{GS} , I _D = 50μA	2.5	3.5	4.5	V
R _{DS(on)}	Static drain-source on resistance	V _{GS} = 10V, I _D = 1.5A		2.3	2.7	Ω

Table 5. Dynamic

Symbol	Parameter	Test conditions	Min.	Typ.	Max.	Unit
g _{fs} ⁽¹⁾	Forward transconductance	V _{DS} = 15V, I _D = 1.5A		1.5		S
C _{iss}	Input capacitance	V _{DS} = 25V, f = 1 MHz, V _{GS} = 0		310		pF
C _{oss}	Output capacitance			49		pF
C _{rss}	Reverse transfer capacitance			10		pF
C _{oss eq} ⁽²⁾	Equivalent output capacitance	V _{GS} = 0, V _{DS} = 0V to 400V		33		pF
Q _g	Total gate charge	V _{DD} = 400V, I _D = 3A V _{GS} = 10V (see Figure 11)		12		nC
Q _{gs}	Gate-source charge			3		nC
Q _{gd}	Gate-drain charge			7		nC

1. Pulsed: pulse duration=300μs, duty cycle 1.5%

2. C_{oss eq} is defined as a constant equivalent capacitance giving the same charging time as C_{oss} when V_{DS} increases from 0 to 80% V_{DSS}

Table 6. Switching times

Symbol	Parameter	Test conditions	Min.	Typ.	Max.	Unit	
t _{d(on)}	Turn-on delay time	V _{DD} = 250 V, I _D = 1.5A, R _G = 4.7Ω, V _{GS} = 10V (see Figure 18)		9.5		ns	
t _r	Rise time			15.5		ns	
t _{d(off)}	Turn-off delay time				23		ns
t _f	Fall time				22		ns

STD4NK50ZD - STD4NK50ZD-1 - STF4NK50ZD - STP4NK50ZD
Electrical characteristics
Table 7. Source drain diode

Symbol	Parameter	Test conditions	Min	Typ.	Max	Unit
I_{SD}	Source-drain current				3	A
$I_{SDM}^{(1)}$	Source-drain current (pulsed)				12	A
$V_{SD}^{(2)}$	Forward on voltage	$I_{SD} = 3A, V_{GS}=0$			1.6	V
t_{rr}	Reverse recovery time	$I_{SD} = 3A,$ $di/dt = 100A/\mu s,$ $V_{DD} = 34V, T_j = 25^\circ C$		73		ns
Q_{rr}	Reverse recovery charge			140		nC
I_{RRM}	Reverse recovery current			3.82		A
t_{rr}	Reverse recovery time	$I_{SD} = 3A,$ $di/dt = 100A/\mu s,$ $V_{DD} = 34V, T_j = 150^\circ C$		118		ns
Q_{rr}	Reverse Recovery Charge			260		nC
I_{RRM}	Reverse recovery current			4.4		A

1. Pulse width limited by safe operating area
2. Pulsed: pulse duration=300 μs , duty cycle 1.5%

Table 8. Gate-source zener diode

Symbol	Parameter	Test conditions	Min.	Typ.	Max	Unit
$BV_{GSO}^{(1)}$	Gate-source breakdown voltage	$I_{GS} = \pm 1mA$ (open drain)	30			V

1. The built-in back-to-back Zener diodes have specifically been designed to enhance not only the device's ESD capability, but also to make them safely absorb possible voltage transients that may occasionally be applied from gate to source. In this respect the Zener voltage is appropriate to achieve an efficient and cost-effective intervention to protect the device's integrity. These integrated Zener diodes thus avoid the usage of external components.

Electrical characteristics

STD4NK50ZD - STD4NK50ZD-1 - STF4NK50ZD - STP4NK50ZD

2.1 Electrical characteristics (curves)

Figure 1. Safe operating area for TO-220

Figure 2. Thermal impedance for TO-220

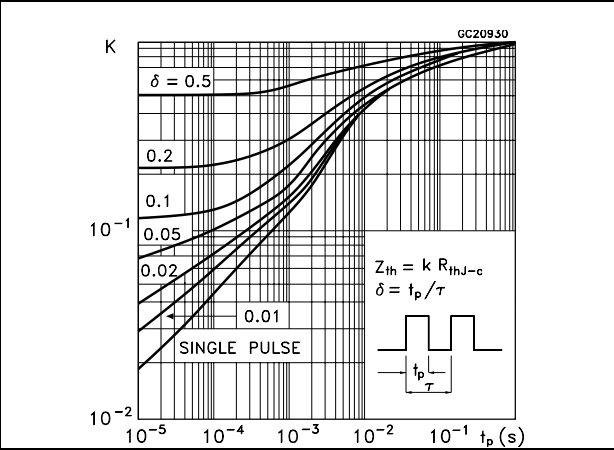
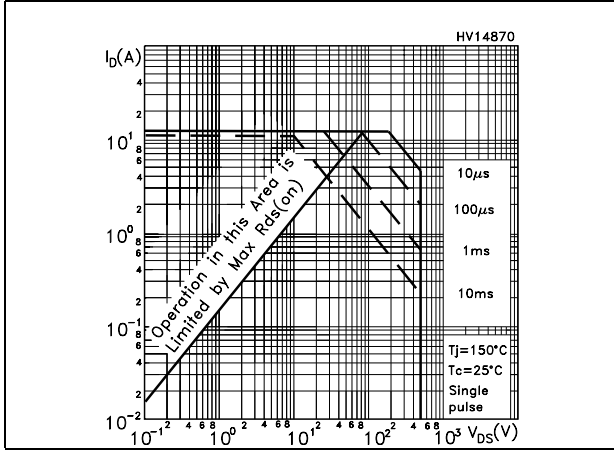

Figure 3. Safe operating area for TO-220FP

Figure 4. Thermal impedance for TO-220FP

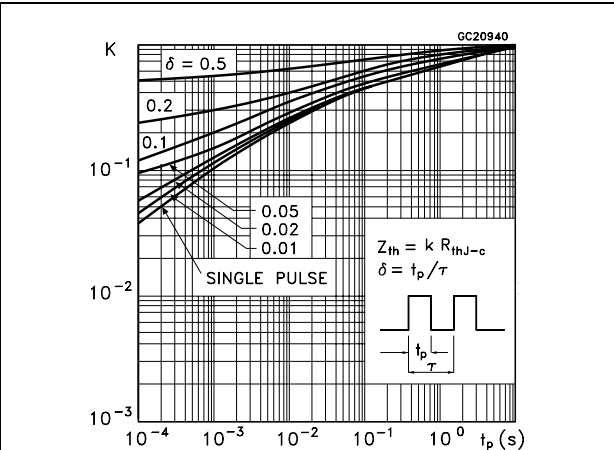
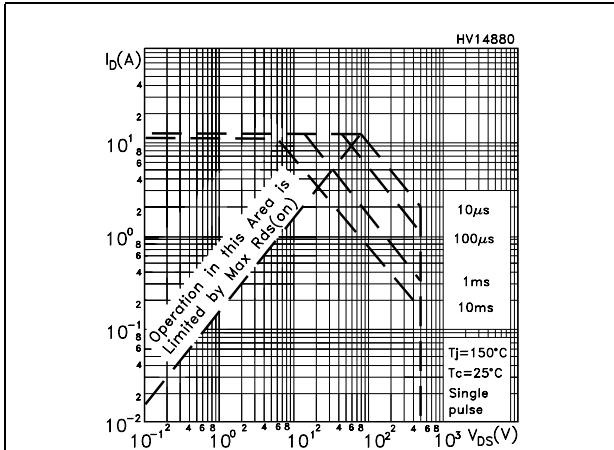
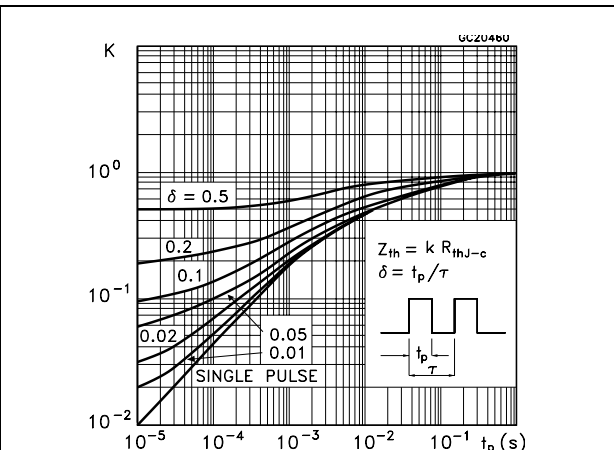
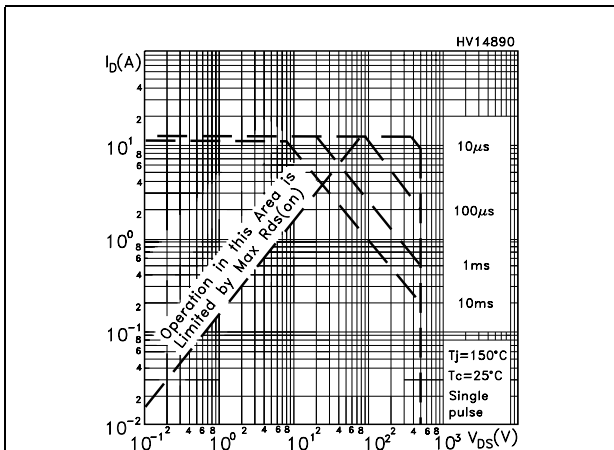

Figure 5. Safe operating area for DPAK/IPAK

Figure 6. Thermal impedance for DPAK/IPAK



STD4NK50ZD - STD4NK50ZD-1 - STF4NK50ZD - STP4NK50ZD

Electrical characteristics

Figure 7. Output characteristics

Figure 8. Transfer characteristics

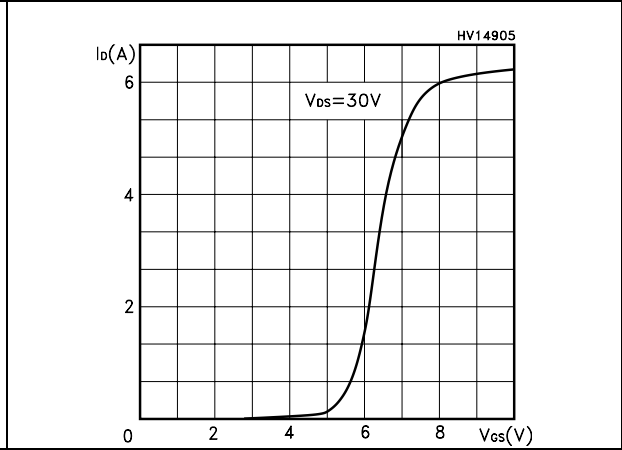
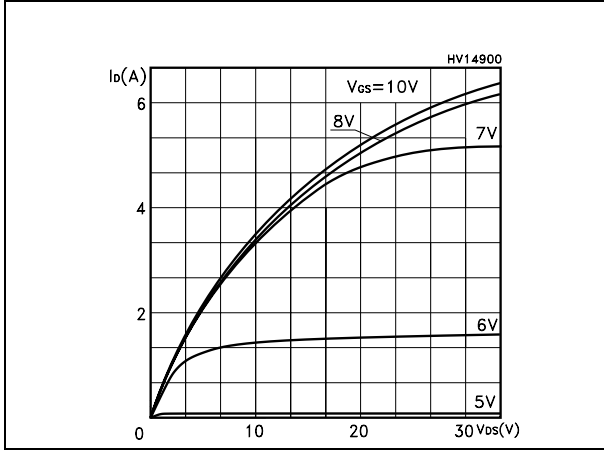

Figure 9. Transconductance

Figure 10. Static drain-source on resistance

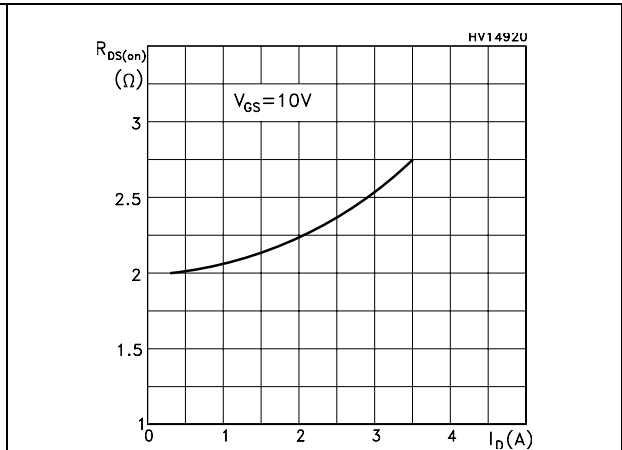
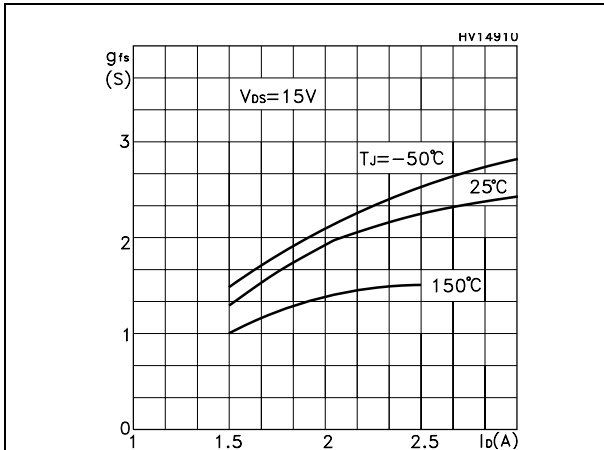
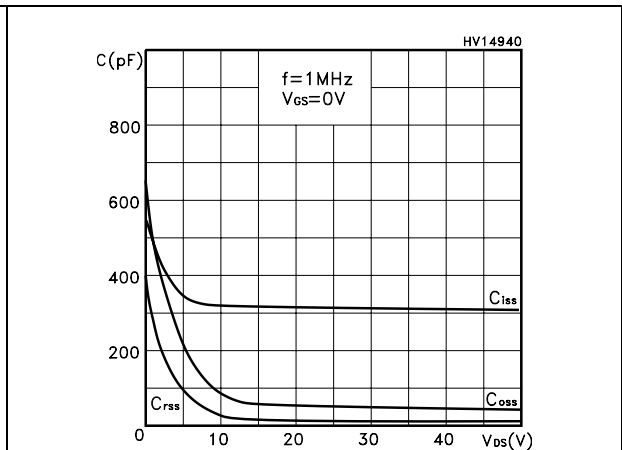
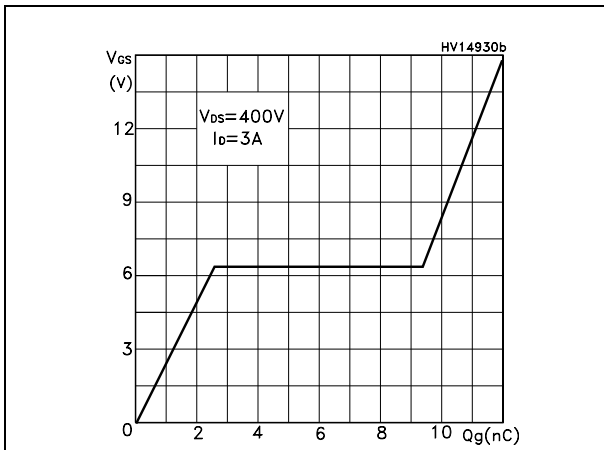

Figure 11. Gate charge vs gate-source voltage **Figure 12. Capacitance variations**



Electrical characteristics

STD4NK50ZD - STD4NK50ZD-1 - STF4NK50ZD - STP4NK50ZD

Figure 13. Normalized gate threshold voltage vs temperature

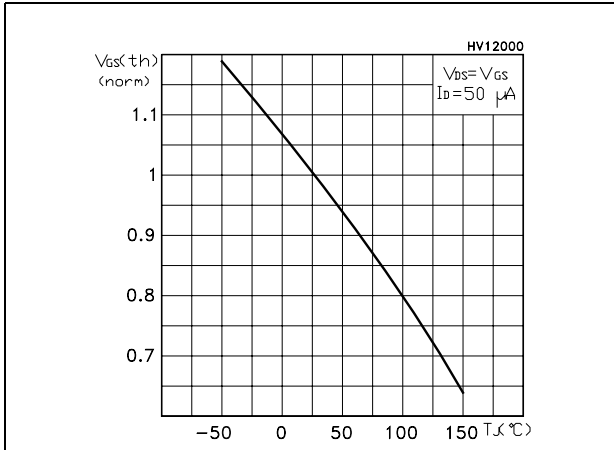

Figure 14. Normalized on resistance vs temperature

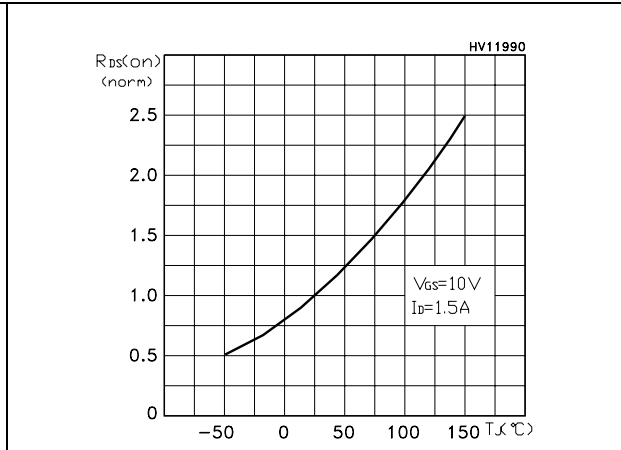

Figure 15. Source-drain diode forward characteristics

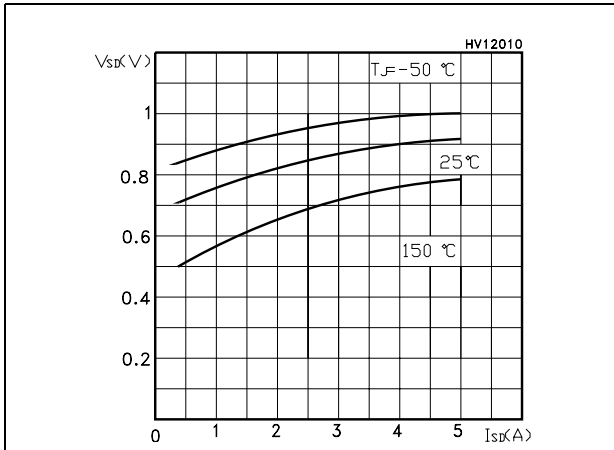

Figure 16. Normalized BV_{DSS} vs temperature

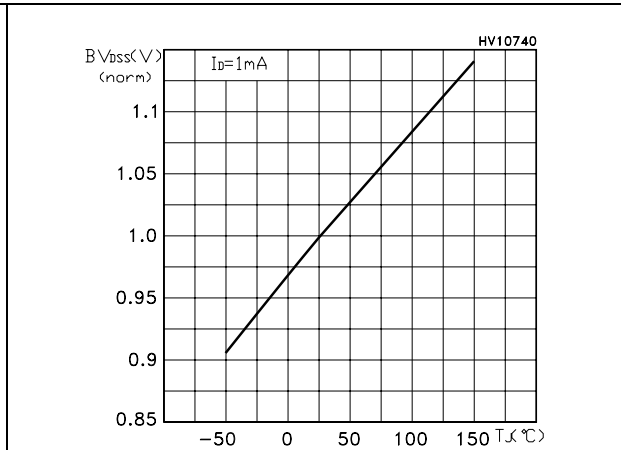
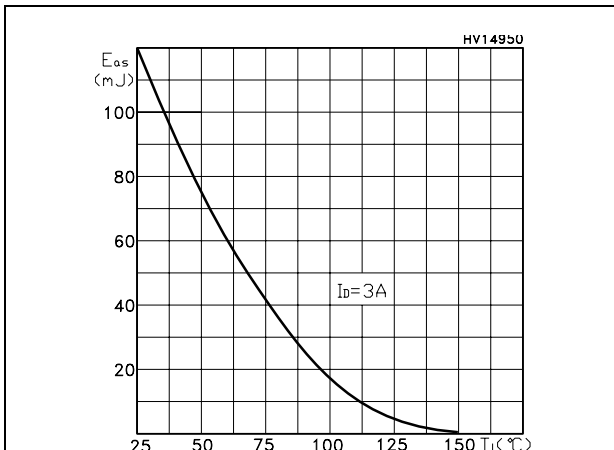

Figure 17. Maximum avalanche energy vs temperature



STD4NK50ZD - STD4NK50ZD-1 - STF4NK50ZD - STP4NK50ZD

Test circuit

3 Test circuit

Figure 18. Switching times test circuit for resistive load

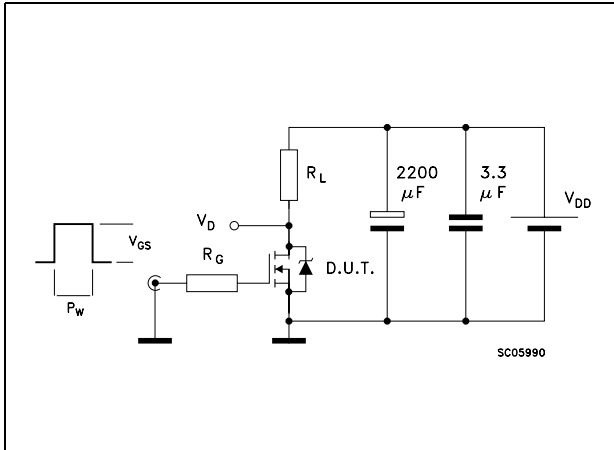

Figure 19. Gate charge test circuit

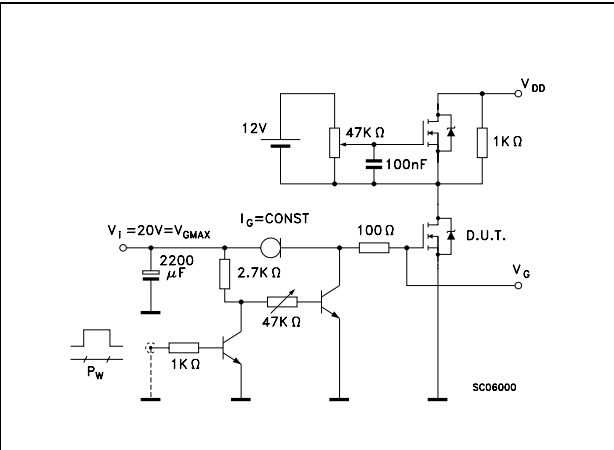

Figure 20. Test circuit for inductive load switching and diode recovery times

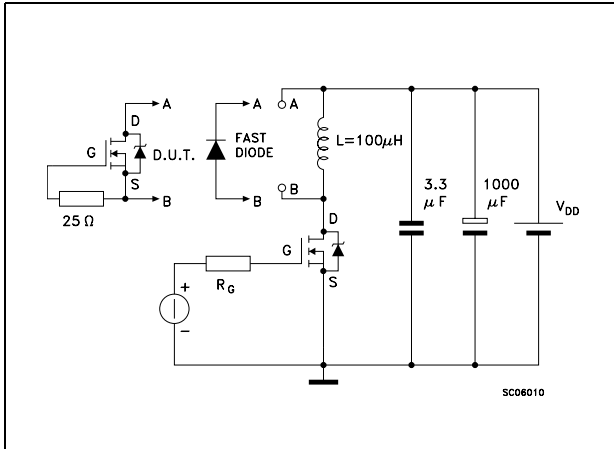

Figure 21. Unclamped inductive load test circuit

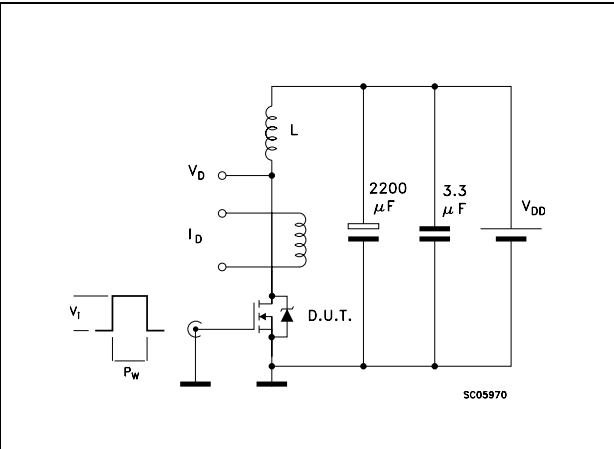

Figure 22. Unclamped inductive waveform

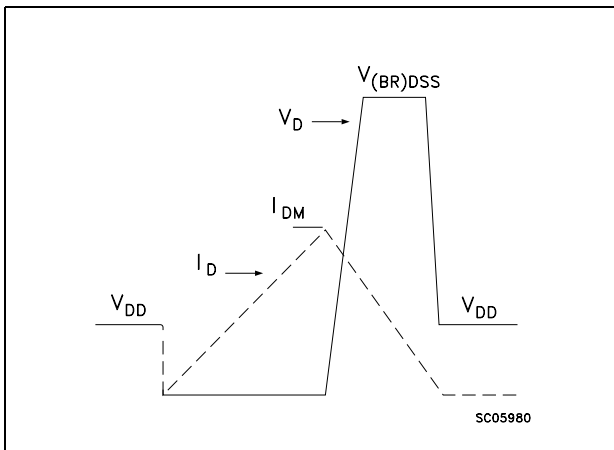
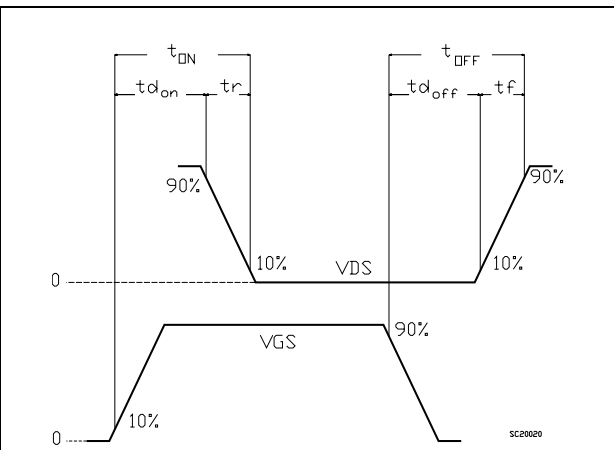

Figure 23. Switching time waveform



4 Package mechanical data

In order to meet environmental requirements, ST offers these devices in ECOPACK® packages. These packages have a Lead-free second level interconnect . The category of second level interconnect is marked on the package and on the inner box label, in compliance with JEDEC Standard JESD97. The maximum ratings related to soldering conditions are also marked on the inner box label. ECOPACK is an ST trademark. ECOPACK specifications are available at: www.st.com

STD4NK50ZD - STD4NK50ZD-1 - STF4NK50ZD - STP4NK50ZD

Package mechanical data

TO-220 MECHANICAL DATA

DIM.	mm.			inch		
	MIN.	TYP.	MAX.	MIN.	TYP.	MAX.
A	4.40		4.60	0.173		0.181
b	0.61		0.88	0.024		0.034
b1	1.15		1.70	0.045		0.066
c	0.49		0.70	0.019		0.027
D	15.25		15.75	0.60		0.620
E	10		10.40	0.393		0.409
e	2.40		2.70	0.094		0.106
e1	4.95		5.15	0.194		0.202
F	1.23		1.32	0.048		0.052
H1	6.20		6.60	0.244		0.256
J1	2.40		2.72	0.094		0.107
L	13		14	0.511		0.551
L1	3.50		3.93	0.137		0.154
L20		16.40			0.645	
L30		28.90			1.137	
øP	3.75		3.85	0.147		0.151
Q	2.65		2.95	0.104		0.116

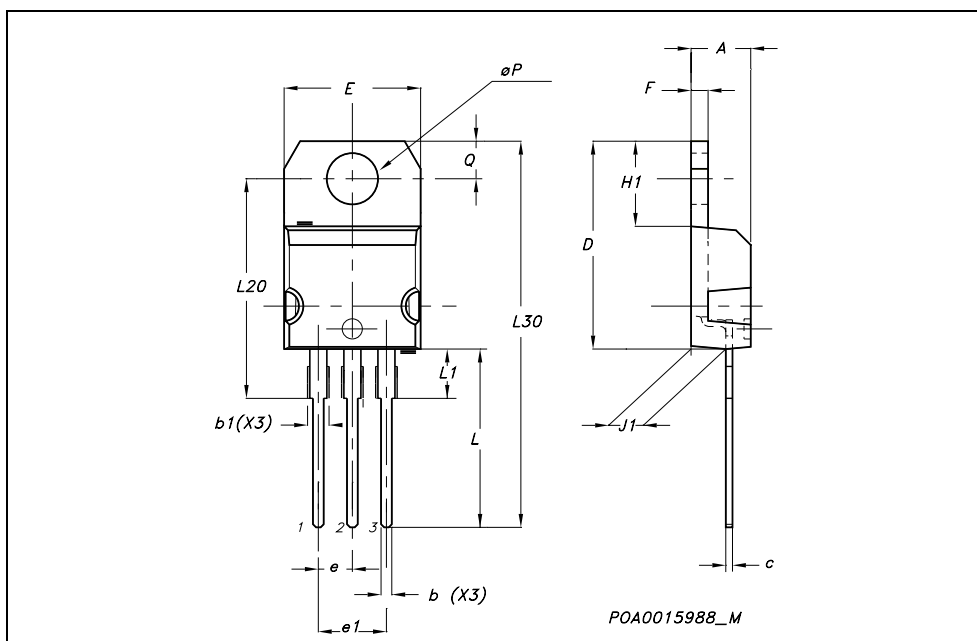

Package mechanical data

STD4NK50ZD - STD4NK50ZD-1 - STF4NK50ZD - STP4NK50ZD

TO-251 (IPAK) MECHANICAL DATA

DIM.	mm			inch		
	MIN.	TYP.	MAX.	MIN.	TYP.	MAX.
A	2.2		2.4	0.086		0.094
A1	0.9		1.1	0.035		0.043
A3	0.7		1.3	0.027		0.051
B	0.64		0.9	0.025		0.031
B2	5.2		5.4	0.204		0.212
B3			0.85			0.033
B5		0.3			0.012	
B6			0.95			0.037
C	0.45		0.6	0.017		0.023
C2	0.48		0.6	0.019		0.023
D	6		6.2	0.236		0.244
E	6.4		6.6	0.252		0.260
G	4.4		4.6	0.173		0.181
H	15.9		16.3	0.626		0.641
L	9		9.4	0.354		0.370
L1	0.8		1.2	0.031		0.047
L2		0.8	1		0.031	0.039

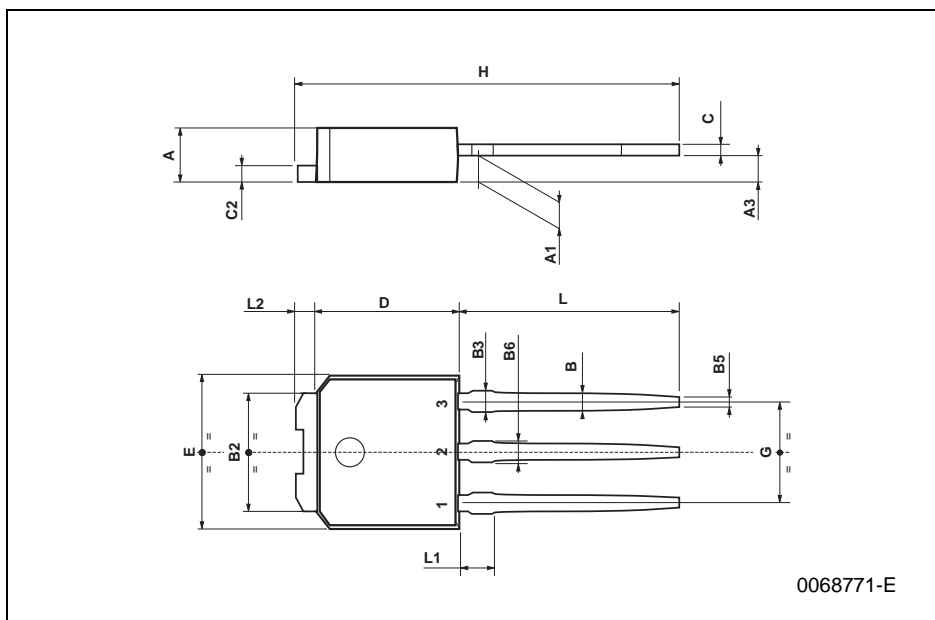

STD4NK50ZD - STD4NK50ZD-1 - STF4NK50ZD - STP4NK50ZD

Package mechanical data

TO-252 (DPAK) MECHANICAL DATA

DIM.	mm			inch		
	MIN.	TYP.	MAX.	MIN.	TYP.	MAX.
A	2.20		2.40	0.087		0.094
A1	0.90		1.10	0.035		0.043
A2	0.03		0.23	0.001		0.009
B	0.64		0.90	0.025		0.035
B2	5.20		5.40	0.204		0.213
C	0.45		0.60	0.018		0.024
C2	0.48		0.60	0.019		0.024
D	6.00		6.20	0.236		0.244
E	6.40		6.60	0.252		0.260
G	4.40		4.60	0.173		0.181
H	9.35		10.10	0.368		0.398
L2		0.8			0.031	
L4	0.60		1.00	0.024		0.039
V2	0°		8°	0°		0°

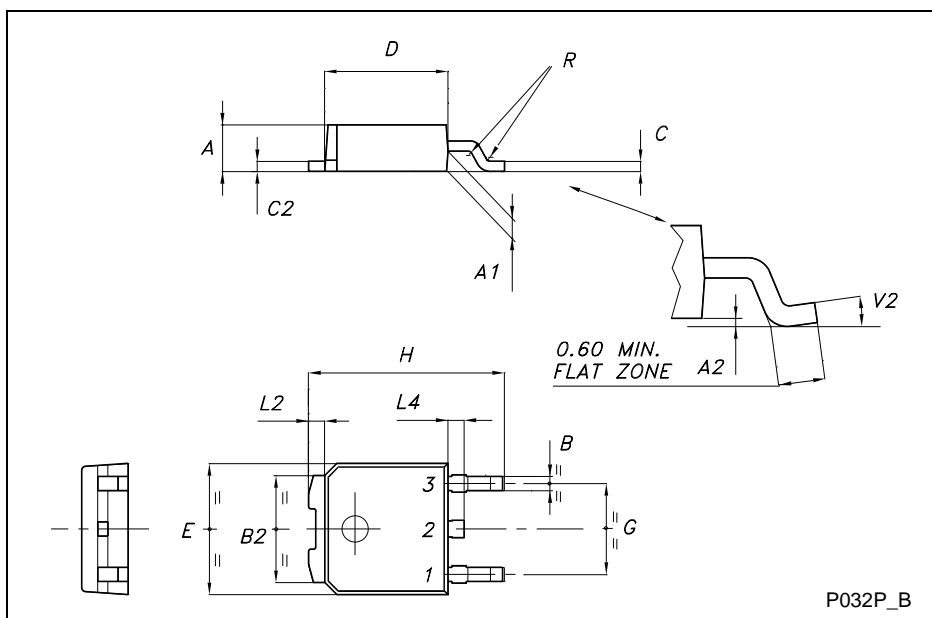

Package mechanical data

STD4NK50ZD - STD4NK50ZD-1 - STF4NK50ZD - STP4NK50ZD

TO-220FP MECHANICAL DATA

DIM.	mm.			inch		
	MIN.	TYP.	MAX.	MIN.	TYP.	MAX.
A	4.4		4.6	0.173		0.181
B	2.5		2.7	0.098		0.106
D	2.5		2.75	0.098		0.108
E	0.45		0.7	0.017		0.027
F	0.75		1	0.030		0.039
F1	1.15		1.7	0.045		0.067
F2	1.15		1.7	0.045		0.067
G	4.95		5.2	0.195		0.204
G1	2.4		2.7	0.094		0.106
H	10		10.4	0.393		0.409
L2		16			0.630	
L3	28.6		30.6	1.126		1.204
L4	9.8		10.6	.0385		0.417
L5	2.9		3.6	0.114		0.141
L6	15.9		16.4	0.626		0.645
L7	9		9.3	0.354		0.366
Ø	3		3.2	0.118		0.126

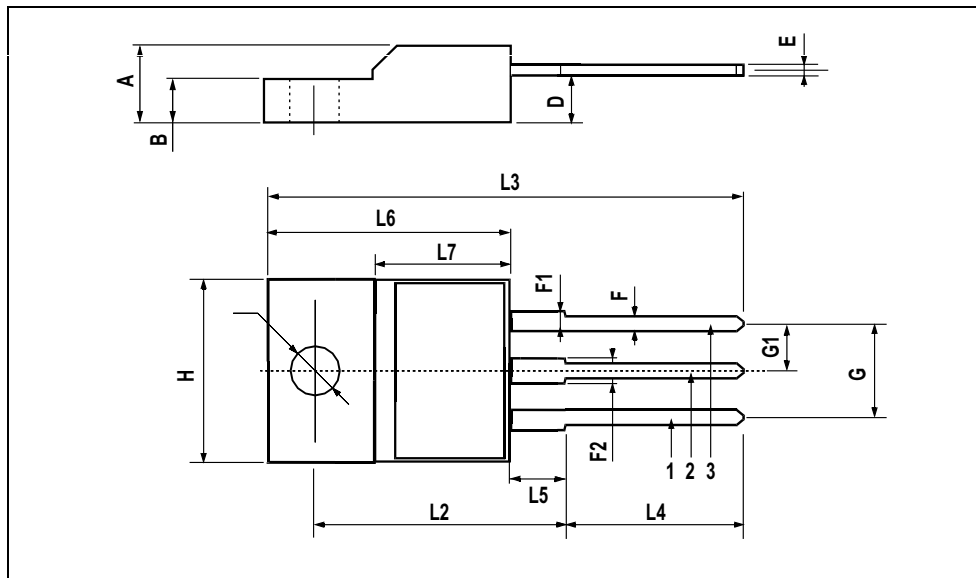

STD4NK50ZD - STD4NK50ZD-1 - STF4NK50ZD - STP4NK50ZD

Packaging mechanical data

5 Packaging mechanical data

DPAK FOOTPRINT

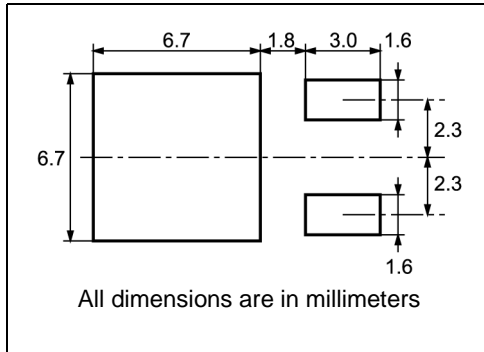

TAPE AND REEL SHIPMENT

40 mm min. Access hole at slot location

Full radius

Tape slot in core for tape start 2.5mm min. width

REEL MECHANICAL DATA

DIM.	mm		inch	
	MIN.	MAX.	MIN.	MAX.
A		330		12.992
B	1.5		0.059	
C	12.8	13.2	0.504	0.520
D	20.2		0.795	
G	16.4	18.4	0.645	0.724
N	50		1.968	
T		22.4		0.881

BASE QTY	BULK QTY
2500	2500

TAPE MECHANICAL DATA

DIM.	mm		inch	
	MIN.	MAX.	MIN.	MAX.
A0	6.8	7	0.267	0.275
B0	10.4	10.6	0.409	0.417
B1		12.1		0.476
D	1.5	1.6	0.059	0.063
D1	1.5		0.059	
E	1.65	1.85	0.065	0.073
F	7.4	7.6	0.291	0.299
K0	2.55	2.75	0.100	0.108
P0	3.9	4.1	0.153	0.161
P1	7.9	8.1	0.311	0.319
P2	1.9	2.1	0.075	0.082
R	40		1.574	
W	15.7	16.3	0.618	0.641

10 pitches cumulative tolerance on tape +/- 0.2 mm

Center line of cavity

User Direction of Feed

TRL

Bending radius R min.

FEED DIRECTION

For machine ref. only including draft and radii concentric around B0

6 Revision history

Table 9. Revision history

Date	Revision	Changes
09-Feb-2006	1	First Release
20-Feb-2006	2	Corrected Part Number
27-Apr-2006	3	Modified curves on page 6

STD4NK50ZD - STD4NK50ZD-1 - STF4NK50ZD - STP4NK50ZD

Please Read Carefully:

Information in this document is provided solely in connection with ST products. STMicroelectronics NV and its subsidiaries ("ST") reserve the right to make changes, corrections, modifications or improvements, to this document, and the products and services described herein at any time, without notice.

All ST products are sold pursuant to ST's terms and conditions of sale.

Purchasers are solely responsible for the choice, selection and use of the ST products and services described herein, and ST assumes no liability whatsoever relating to the choice, selection or use of the ST products and services described herein.

No license, express or implied, by estoppel or otherwise, to any intellectual property rights is granted under this document. If any part of this document refers to any third party products or services it shall not be deemed a license grant by ST for the use of such third party products or services, or any intellectual property contained therein or considered as a warranty covering the use in any manner whatsoever of such third party products or services or any intellectual property contained therein.

UNLESS OTHERWISE SET FORTH IN ST'S TERMS AND CONDITIONS OF SALE ST DISCLAIMS ANY EXPRESS OR IMPLIED WARRANTY WITH RESPECT TO THE USE AND/OR SALE OF ST PRODUCTS INCLUDING WITHOUT LIMITATION IMPLIED WARRANTIES OF MERCHANTABILITY, FITNESS FOR A PARTICULAR PURPOSE (AND THEIR EQUIVALENTS UNDER THE LAWS OF ANY JURISDICTION), OR INFRINGEMENT OF ANY PATENT, COPYRIGHT OR OTHER INTELLECTUAL PROPERTY RIGHT.

UNLESS EXPRESSLY APPROVED IN WRITING BY AN AUTHORIZED REPRESENTATIVE OF ST, ST PRODUCTS ARE NOT DESIGNED, AUTHORIZED OR WARRANTED FOR USE IN MILITARY, AIR CRAFT, SPACE, LIFE SAVING, OR LIFE SUSTAINING APPLICATIONS, NOR IN PRODUCTS OR SYSTEMS, WHERE FAILURE OR MALFUNCTION MAY RESULT IN PERSONAL INJURY, DEATH, OR SEVERE PROPERTY OR ENVIRONMENTAL DAMAGE.

Resale of ST products with provisions different from the statements and/or technical features set forth in this document shall immediately void any warranty granted by ST for the ST product or service described herein and shall not create or extend in any manner whatsoever, any liability of ST.

ST and the ST logo are trademarks or registered trademarks of ST in various countries.

Information in this document supersedes and replaces all information previously supplied.

The ST logo is a registered trademark of STMicroelectronics. All other names are the property of their respective owners.

© 2006 STMicroelectronics - All rights reserved

STMicroelectronics group of companies

Australia - Belgium - Brazil - Canada - China - Czech Republic - Finland - France - Germany - Hong Kong - India - Israel - Italy - Japan - Malaysia - Malta - Morocco - Singapore - Spain - Sweden - Switzerland - United Kingdom - United States of America

www.st.com