

Excellent Integrated System Limited

Stocking Distributor

Click to view price, real time Inventory, Delivery & Lifecycle Information:

[E-Switch](#)
[TL1105FF160Q](#)

For any questions, you can email us directly:

sales@integrated-circuit.com

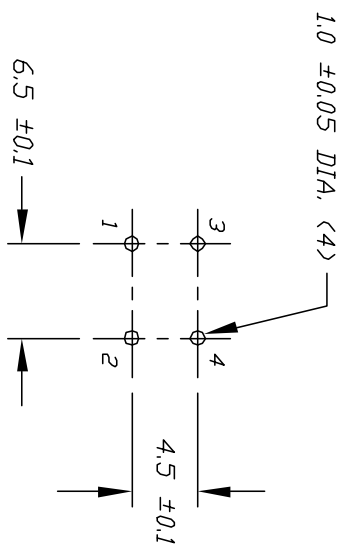
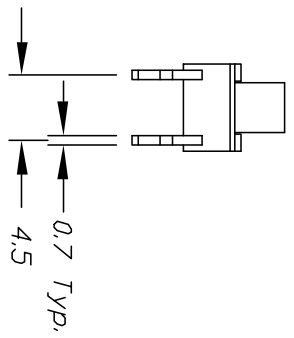
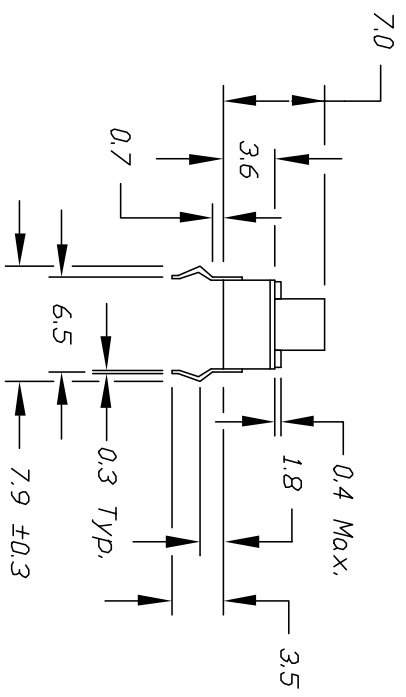
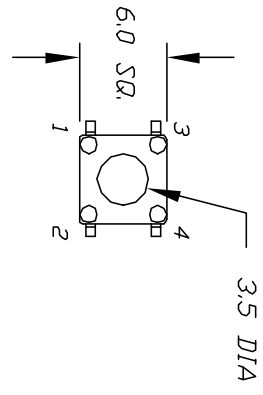

RECOMMEND P.C.B. LAYOUT

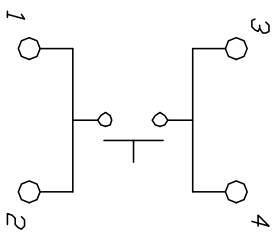

CIRCUIT: SPST
 CONTACT CONFIGURATION

NOTES:

1. ALL DIMENSIONS IN MM
2. TERM. NDS. FOR REF ONLY
3. ACTUATION FORCE: TYPICAL 160±50gf
4. RATING: 50mA, 12V DC
5. CONTACT RESISTANCE: 100 milliohms Max.

REV.	B	REVISED & REDRAWN	8/5/97	DATE	CHKD
DESCRIPTION					
THE INFORMATION CONTAINED IN THIS DOCUMENT IS PROPRIETARY TO E-SWITCH AND IS NOT TO BE COPIED OR TRANSMITTED					

TOLERANCES	
0.0	±0.4
0.00	±0.25

TITLE	TL 1105 F F160 Q			
SCALE	2:1	DATE	8/1/96	DR
				MM
				DWG
				P010007
REV	B			

