

## Excellent Integrated System Limited

Stocking Distributor

Click to view price, real time Inventory, Delivery & Lifecycle Information:

[NXP Semiconductors/Freescale Semiconductor, Inc.](#)  
[PHE13009,127](#)

For any questions, you can email us directly:

[sales@integrated-circuit.com](mailto:sales@integrated-circuit.com)

Philips Semiconductors

Preliminary specification

## Silicon Diffused Power Transistor

PHE13009

### GENERAL DESCRIPTION

The PHE13009 is a silicon npn power switching transistor in the TO220AB envelope intended for use in high frequency electronic lighting ballast applications, converters, inverters, switching regulators, motor control systems, etc.

### QUICK REFERENCE DATA

SYMBOL	PARAMETER	CONDITIONS	TYP.	MAX.	UNIT
$V_{CESM}$	Collector-emitter voltage peak value	$V_{BE} = 0\text{ V}$	-	700	V
$V_{CBO}$	Collector-Base voltage (open emitter)		-	700	V
$V_{CEO}$	Collector-emitter voltage (open base)		-	400	V
$I_C$	Collector current (DC)		-	12	A
$I_{CM}$	Collector current peak value		-	24	A
$P_{tot}$	Total power dissipation	$T_{mb} \leq 25\text{ }^\circ\text{C}$	-	80	W
$V_{CEsat}$	Collector-emitter saturation voltage	$I_C = 5.0\text{ A}; I_B = 1.0\text{ A}$	0.32	1.0	V
$h_{FEsat}$		$I_C = 5.0\text{ A}; V_{CE} = 5\text{ V}$	-	40	
$t_f$	Fall time	$I_C = 5.0\text{ A}; I_{B1} = 1.0\text{ A}$	0.1	0.5	$\mu\text{s}$

### PINNING - TO220AB

PIN	DESCRIPTION
1	base
2	collector
3	emitter
tab	collector

### PIN CONFIGURATION

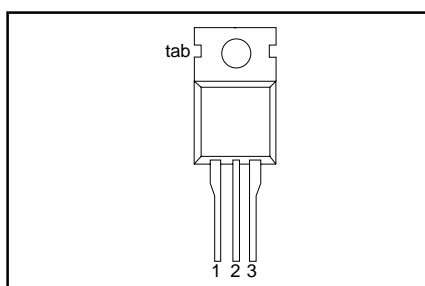

### SYMBOL

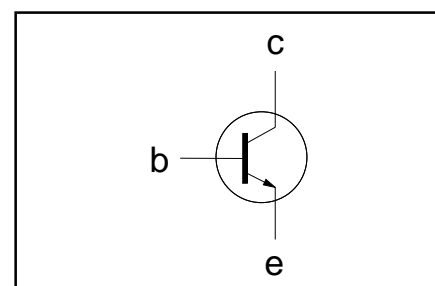

### LIMITING VALUES

Limiting values in accordance with the Absolute Maximum Rating System (IEC 134)

SYMBOL	PARAMETER	CONDITIONS	MIN.	MAX.	UNIT
$V_{CESM}$	Collector to emitter voltage	$V_{BE} = 0\text{ V}$	-	700	V
$V_{CEO}$	Collector to emitter voltage (open base)		-	400	V
$V_{CBO}$	Collector to base voltage (open emitter)		-	700	V
$I_C$	Collector current (DC)		-	12	A
$I_{CM}$	Collector current peak value		-	24	A
$I_B$	Base current (DC)		-	6	A
$I_{BM}$	Base current peak value		-	12	A
$P_{tot}$	Total power dissipation	$T_{mb} \leq 25\text{ }^\circ\text{C}$	-	80	W
$T_{stg}$	Storage temperature		-65	150	$^\circ\text{C}$
$T_j$	Junction temperature		-	150	$^\circ\text{C}$

### THERMAL RESISTANCES

SYMBOL	PARAMETER	CONDITIONS	TYP.	MAX.	UNIT
$R_{th\ j-mb}$	Junction to mounting base		-	1.56	K/W
$R_{th\ j-a}$	Junction to ambient	in free air	60	-	K/W

Philips Semiconductors

Preliminary specification

## Silicon Diffused Power Transistor

PHE13009

### STATIC CHARACTERISTICS

$T_{mb} = 25\text{ }^{\circ}\text{C}$  unless otherwise specified

SYMBOL	PARAMETER	CONDITIONS	MIN.	TYP.	MAX.	UNIT
$I_{CES}, I_{CBO}$ $I_{CES}$	Collector cut-off current <sup>1</sup>	$V_{BE} = 0\text{ V}; V_{CE} = V_{CESMmax}$ $V_{BE} = 0\text{ V}; V_{CE} = V_{CESMmax}$ $T_j = 125\text{ }^{\circ}\text{C}$	-	-	1.0 5.0	mA mA
$I_{CEO}$ $I_{EBO}$ $V_{CEOsust}$	Collector cut-off current Emitter cut-off current Collector-emitter sustaining voltage	$V_{CEO} = V_{CEOMmax} (400\text{V})$ $V_{EB} = 9\text{ V}; I_C = 0\text{ A}$ $I_B = 0\text{ A}; I_C = 10\text{ mA};$ $L = 25\text{ mH}$	-	-	0.1 1 -	mA mA V
$V_{CEsat}$	Collector-emitter saturation voltage	$I_C = 5.0\text{ A}; I_B = 1.0\text{ A}$ $I_C = 8.0\text{ A}; I_B = 1.6\text{ A}$	400	-	-	V
$V_{BEsat}$	Base-emitter saturation voltage	$I_C = 5.0\text{ A}; I_B = 1.0\text{ A}$ $I_C = 8.0\text{ A}; I_B = 1.6\text{ A}$	-	0.32	1.0 2.0	V V
$h_{FE}$ $h_{FEsat}$	DC current gain	$I_C = 5.0\text{ A}; V_{CE} = 5\text{ V}$ $I_C = 8.0\text{ A}; V_{CE} = 5\text{ V}$	-	1.0 1.1	1.3 1.6	V V
			8	-	40	
			6	-	30	

### DYNAMIC CHARACTERISTICS

$T_{mb} = 25\text{ }^{\circ}\text{C}$  unless otherwise specified

SYMBOL	PARAMETER	CONDITIONS	TYP.	MAX.	UNIT
	Switching times (resistive load)	$I_{Con} = 5\text{ A}; I_{Bon} = -I_{Boff} = 1\text{ A};$ $R_L = 75\text{ ohms}; V_{BB2} = 4\text{ V};$			
$t_s$ $t_f$	Turn-off storage time Turn-off fall time		2.2 0.26	3.3 0.7	$\mu\text{s}$ $\mu\text{s}$
	Switching times (inductive load)	$I_{Con} = 5\text{ A}; I_{Bon} = 1\text{ A}; L_B = 1\text{ }\mu\text{H};$ $-V_{BB} = 5\text{ V}$			
$t_s$ $t_f$	Turn-off storage time Turn-off fall time		1.35 0.1	2.3 0.5	$\mu\text{s}$ $\mu\text{s}$
	Switching times (inductive load)	$I_{Con} = 5\text{ A}; I_{Bon} = 1\text{ A}; L_B = 1\text{ }\mu\text{H};$ $-V_{BB} = 5\text{ V}; T_j = 100\text{ }^{\circ}\text{C}$			
$t_s$ $t_f$	Turn-off storage time Turn-off fall time		- -	3.2 0.9	$\mu\text{s}$ $\mu\text{s}$

<sup>1</sup> Measured with half sine-wave voltage (curve tracer).

Silicon Diffused Power Transistor

PHE13009

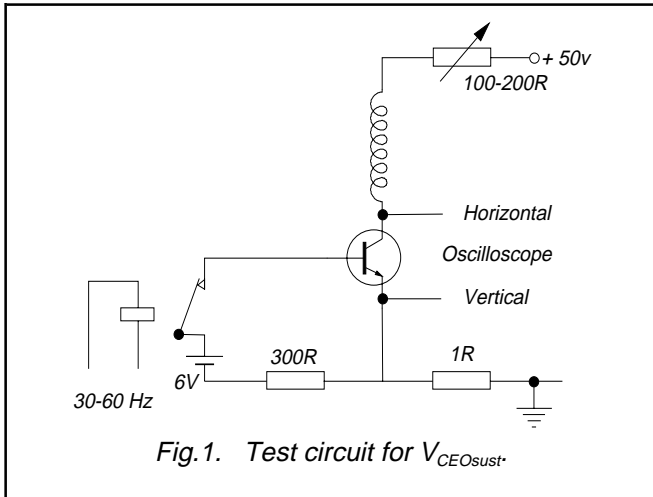

Fig.1. Test circuit for  $V_{CEOsust}$

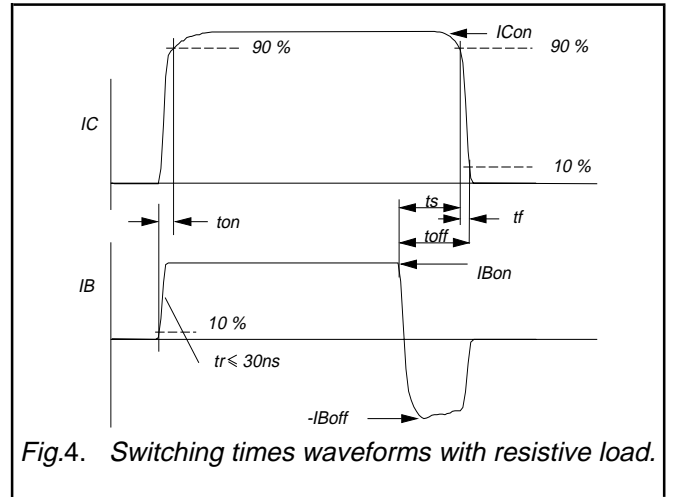

Fig.4. Switching times waveforms with resistive load.

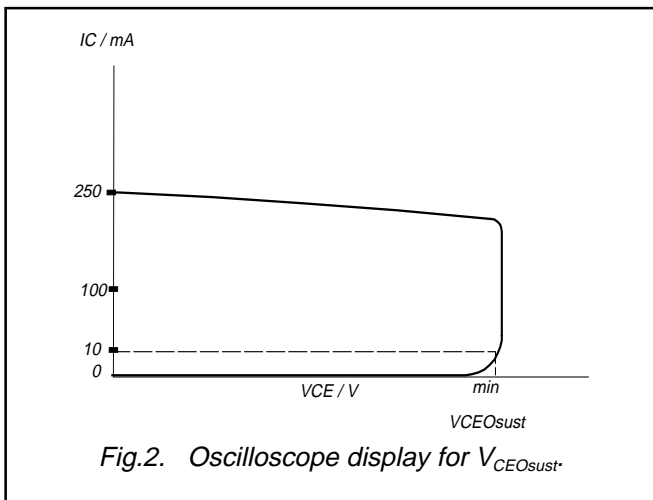

Fig.2. Oscilloscope display for  $V_{CEOsust}$

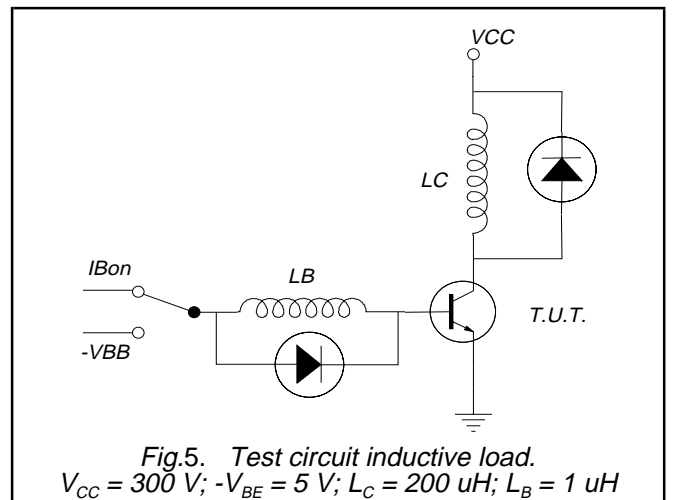

Fig.5. Test circuit inductive load.  
 $V_{CC} = 300 V$ ;  $-V_{BE} = 5 V$ ;  $L_C = 200 \mu H$ ;  $L_B = 1 \mu H$

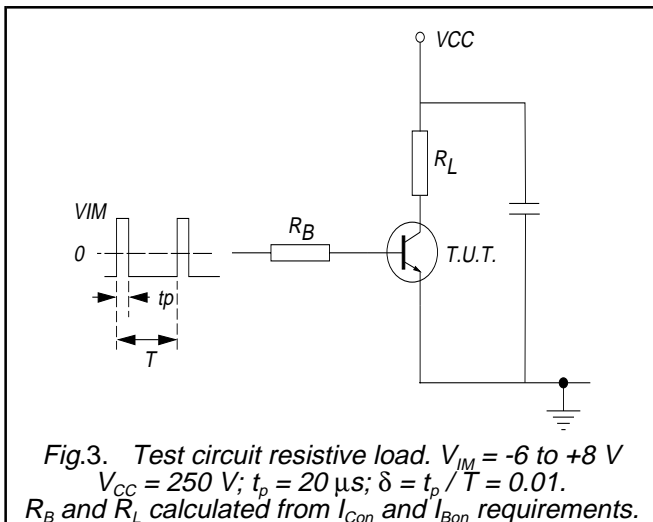

Fig.3. Test circuit resistive load.  $V_{IM} = -6$  to  $+8 V$   
 $V_{CC} = 250 V$ ;  $t_p = 20 \mu s$ ;  $\delta = t_p / T = 0.01$ .  
 $R_B$  and  $R_L$  calculated from  $I_{Con}$  and  $I_{Bon}$  requirements.

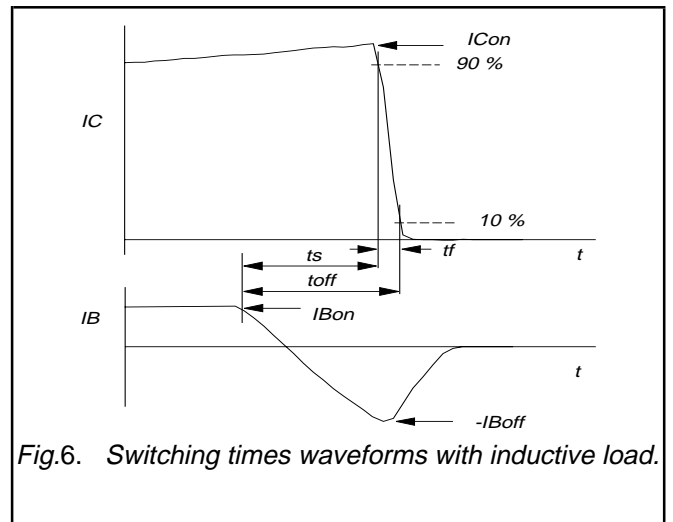
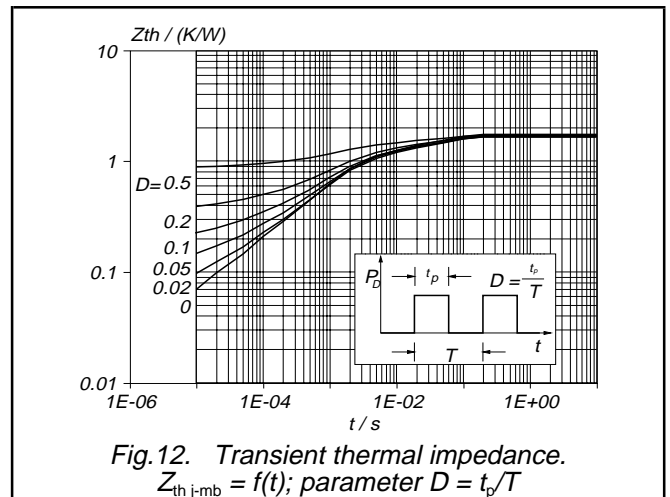
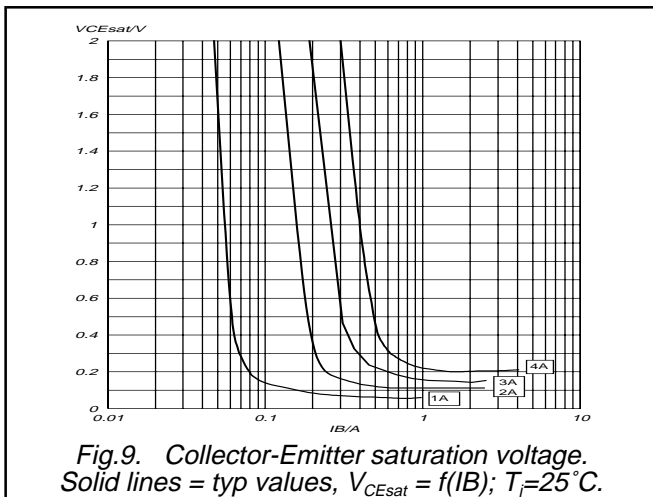
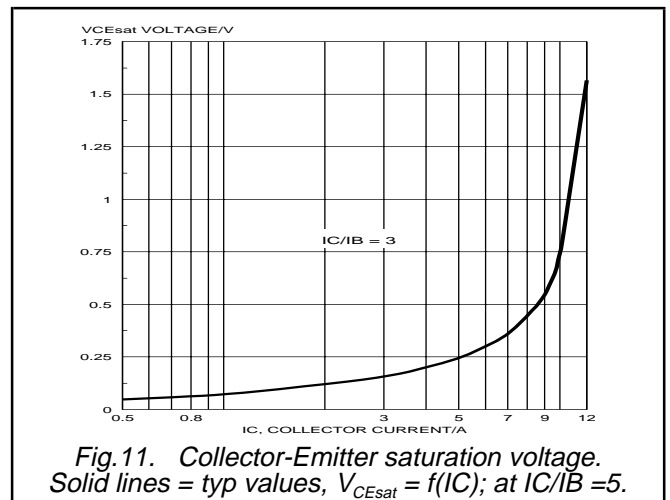
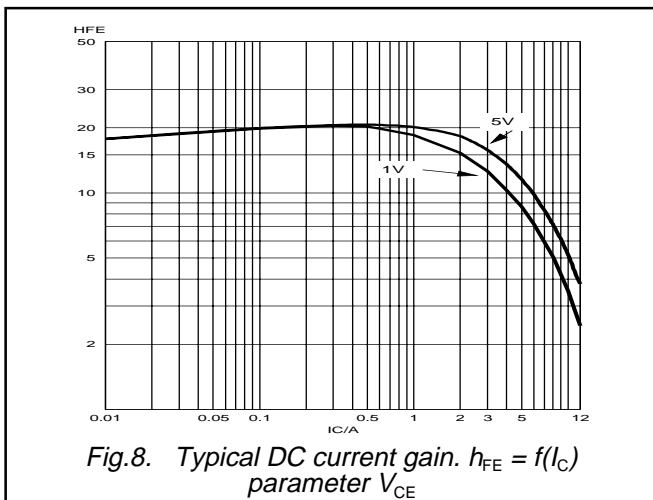
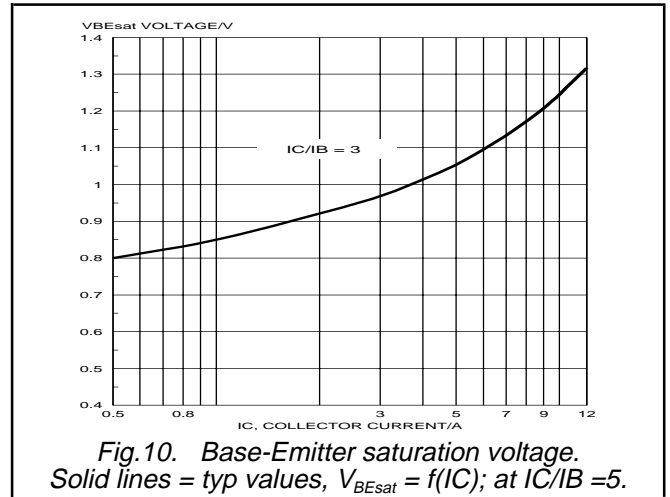
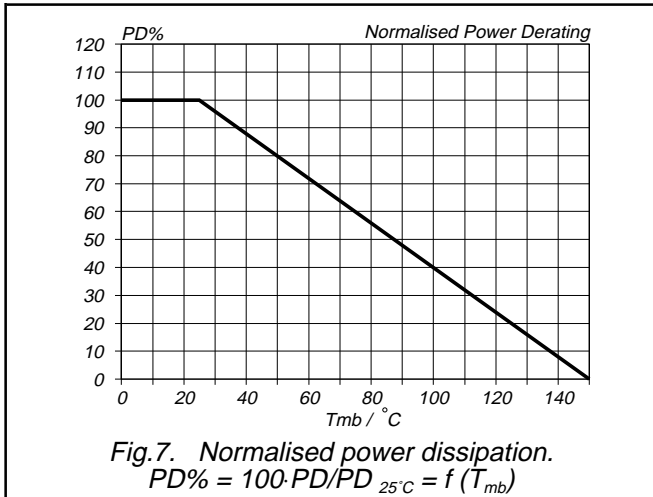

Fig.6. Switching times waveforms with inductive load.

Silicon Diffused Power Transistor

PHE13009



Silicon Diffused Power Transistor

PHE13009

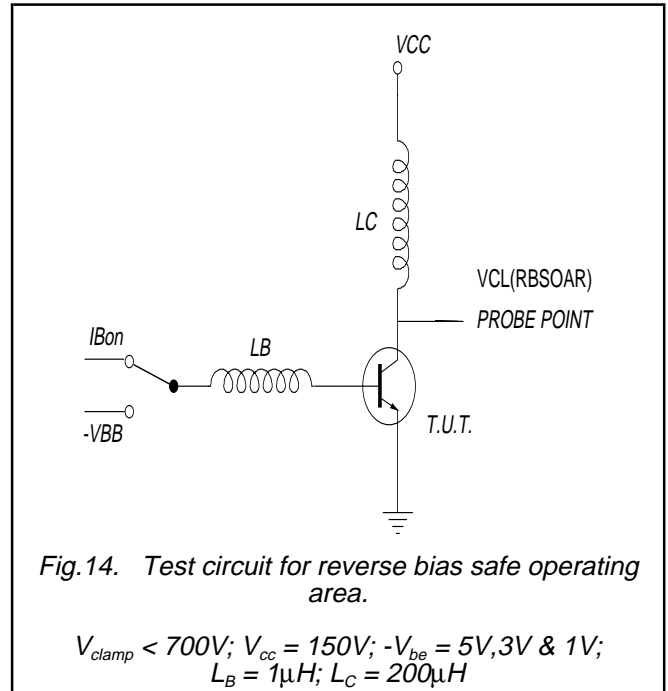
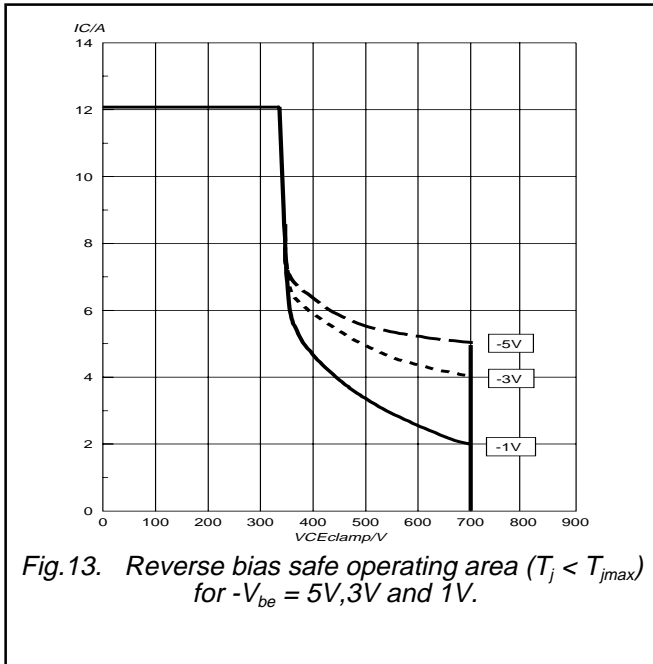

**MECHANICAL DATA**

Dimensions in mm

Net Mass: 2 g

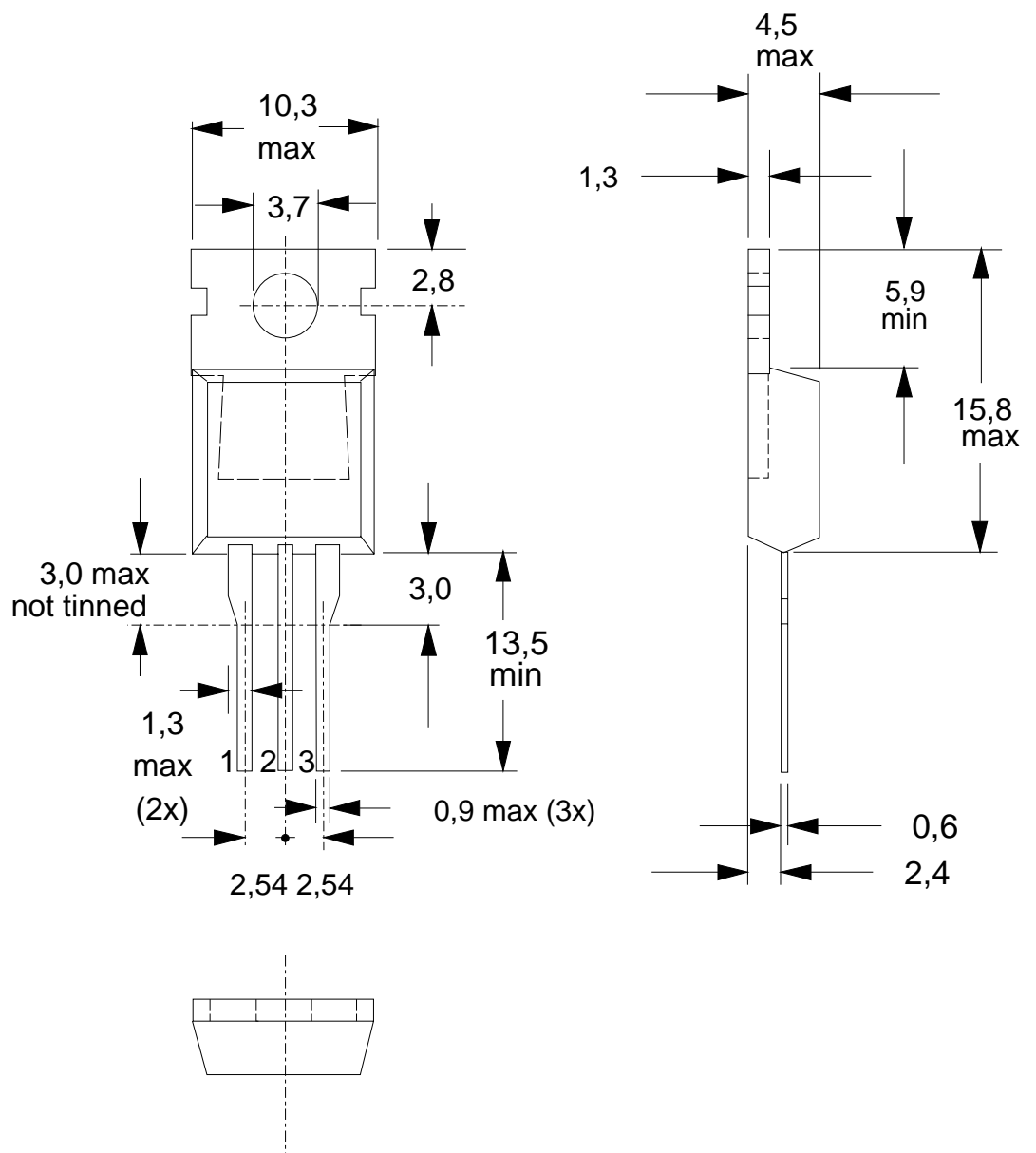

Fig.15. TO220AB; pin 2 connected to mounting base.

**Notes**

1. Refer to mounting instructions for TO220 envelopes.
2. Epoxy meets UL94 V0 at 1/8".

Philips Semiconductors

Preliminary specification

Silicon Diffused Power Transistor

PHE13009

## DEFINITIONS

<b>Data sheet status</b>	
Objective specification	This data sheet contains target or goal specifications for product development.
Preliminary specification	This data sheet contains preliminary data; supplementary data may be published later.
Product specification	This data sheet contains final product specifications.
<b>Limiting values</b>	
Limiting values are given in accordance with the Absolute Maximum Rating System (IEC 134). Stress above one or more of the limiting values may cause permanent damage to the device. These are stress ratings only and operation of the device at these or at any other conditions above those given in the Characteristics sections of this specification is not implied. Exposure to limiting values for extended periods may affect device reliability.	
<b>Application information</b>	
Where application information is given, it is advisory and does not form part of the specification.	
<b>© Philips Electronics N.V. 1999</b>	
All rights are reserved. Reproduction in whole or in part is prohibited without the prior written consent of the copyright owner.	
The information presented in this document does not form part of any quotation or contract, it is believed to be accurate and reliable and may be changed without notice. No liability will be accepted by the publisher for any consequence of its use. Publication thereof does not convey nor imply any license under patent or other industrial or intellectual property rights.	

## LIFE SUPPORT APPLICATIONS

These products are not designed for use in life support appliances, devices or systems where malfunction of these products can be reasonably expected to result in personal injury. Philips customers using or selling these products for use in such applications do so at their own risk and agree to fully indemnify Philips for any damages resulting from such improper use or sale.