

Excellent Integrated System Limited

Stocking Distributor

Click to view price, real time Inventory, Delivery & Lifecycle Information:

[Pomona Electronics](#)
[72910](#)

For any questions, you can email us directly:

sales@integrated-circuit.com

Models 72910
IEC Insulated BNC (M) to 2 male banana 4 mm plugs

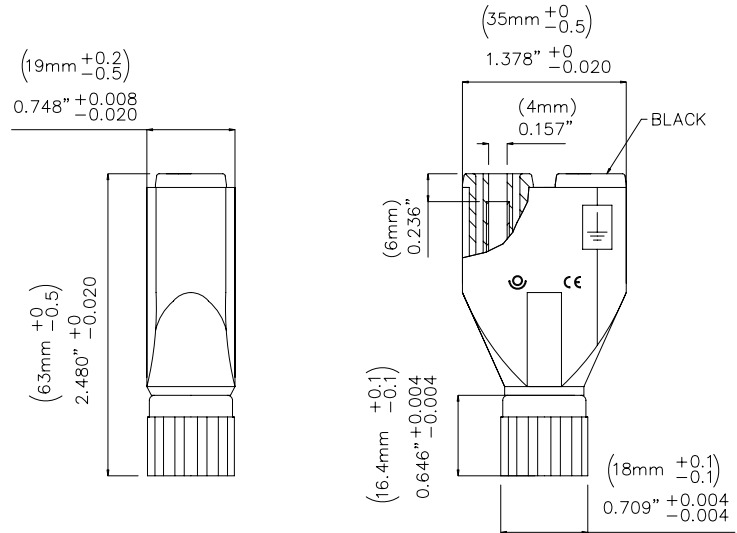

Features

- IEC Insulated BNC (M) to 2 male banana 4 mm plugs
- Adapter converts Double banana Jack Test Instruments to BNC configuration for added shielding.
- Rating: 500V Cat I, 150V Cat II

Materials

- Connector body: Nickel plated Brass
- Center Contact: Gold Plated Brass
- Dielectric: White PTFE
- Insulation: Polyamide
- Plug spring: Nickel plated bronze Beryllium copper.
- Plug Body: Nickel plated Brass
- Plug Insulation: Polysulfone

Specifications

Max Current	3A
Max Voltage	500V CAT I, 150V CATII

Ordering Information

Model: 72910

USA: Sales: 800-490-2361 Technical Support: 800-241-2060 Fax: 888-403-3360

Europe: 31-(0) 40 2675 150 **International:** 425-446-5500

e-mail: technicalsupport@pomonatest.com

Where to Buy: www.pomonaelectronics.com

All dimensions are in inches. Tolerances (except noted): .xx = ±.02" (.51 mm), .xxx = ±.005" (.127 mm). All specifications are to the latest revisions. Specifications are subject to change without notice. Registered trademarks are the property of their respective companies.