

Excellent Integrated System Limited

Stocking Distributor

Click to view price, real time Inventory, Delivery & Lifecycle Information:

[Cypress Semiconductor](#)
[CY62167DV30LL-45ZXI](#)

For any questions, you can email us directly:

sales@integrated-circuit.com



CY62167DV30 MoBL®

16-Mbit (1M x 16) Static RAM

Features

- **TSOP I Configurable as 1M x 16 or as 2M x 8 SRAM**
- **Very high speed: 45 ns**
- **Wide voltage range: 2.2V – 3.6V**
- **Ultra-low active power**
 - Typical active current: 2 mA @ f = 1 MHz
 - Typical active current: 18.5 mA @ f = f_{Max} (45 ns speed)
- **Ultra-low standby power**
- **Easy memory expansion with \overline{CE}_1 , CE_2 and \overline{OE} features**
- **Automatic power-down when deselected**
- **CMOS for optimum speed/power**
- **Available in Pb-free and non Pb-free 48-ball VFBGA and 48-pin TSOP I package**

also has an automatic power-down feature that significantly reduces power consumption by 99% when addresses are not toggling. The device can also be put into standby mode when deselected (\overline{CE}_1 HIGH or CE_2 LOW or both BHE and BLE are HIGH). The input/output pins (I/O₀ through I/O₁₅) are placed in a high-impedance state when: deselected (\overline{CE}_1 HIGH or CE_2 LOW), outputs are disabled (\overline{OE} HIGH), both Byte High Enable and Byte Low Enable are disabled (\overline{BHE} , BLE HIGH), or during a Write operation (CE_1 LOW, CE_2 HIGH and WE LOW).

Writing to the device is accomplished by taking Chip Enables (\overline{CE}_1 LOW and CE_2 HIGH) and Write Enable (WE) input LOW. If Byte Low Enable (BLE) is LOW, then data from I/O pins (I/O₀ through I/O₇), is written into the location specified on the address pins (A₀ through A₁₉). If Byte High Enable (BHE) is LOW, then data from I/O pins (I/O₈ through I/O₁₅) is written into the location specified on the address pins (A₀ through A₁₉).

Reading from the device is accomplished by taking Chip Enables (\overline{CE}_1 LOW and CE_2 HIGH) and Output Enable (\overline{OE}) LOW while forcing the Write Enable (WE) HIGH. If Byte Low Enable (BLE) is LOW, then data from the memory location specified by the address pins will appear on I/O₀ to I/O₇. If Byte High Enable (BHE) is LOW, then data from memory will appear on I/O₈ to I/O₁₅. See the truth table at the back of this data sheet for a complete description of Read and Write modes.

Functional Description^[1]

The CY62167DV30 is a high-performance CMOS static RAM organized as 1M words by 16 bits. This device features advanced circuit design to provide ultra-low active current. This is ideal for providing More Battery Life™ (MoBL®) in portable applications such as cellular telephones. The device

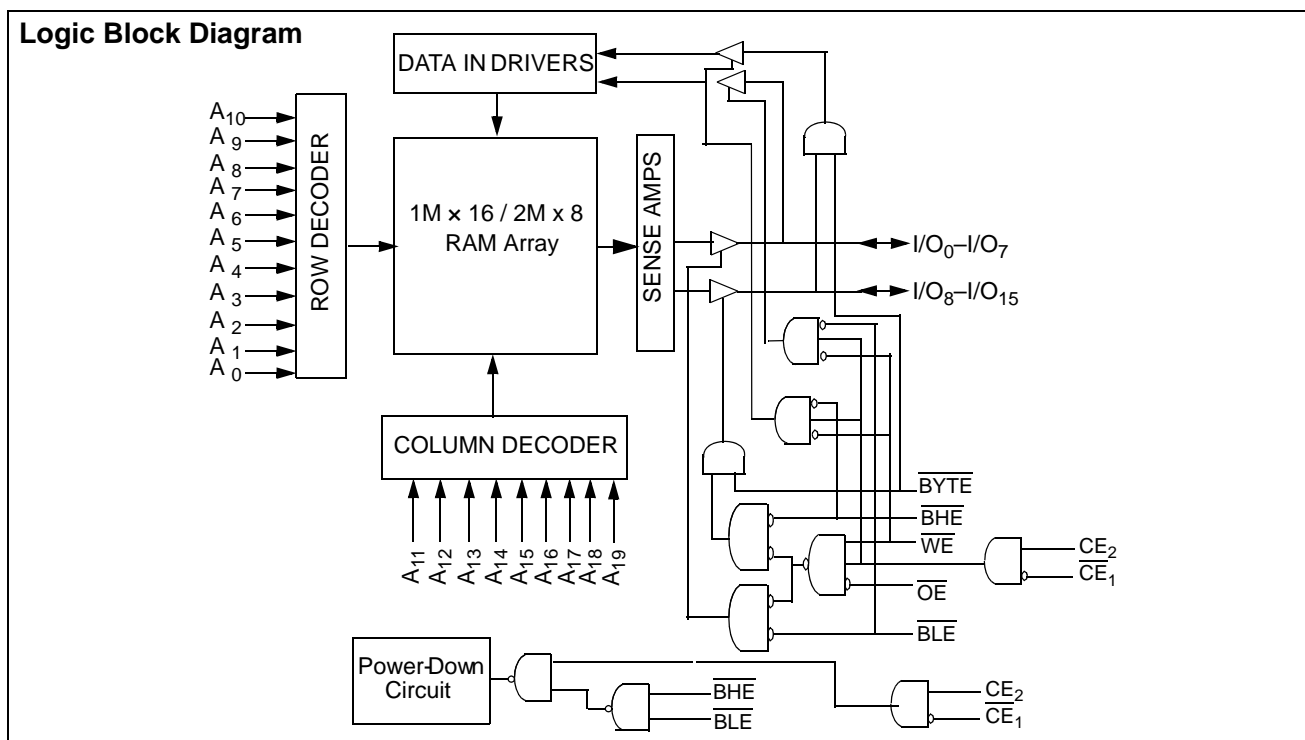

Note:

1. For best-practice recommendations, please refer to the Cypress application note "System Design Guidelines" on <http://www.cypress.com>.



CY62167DV30 MoBL®

Product Portfolio

Product	V _{CC} Range (V)			Speed (ns)	Power Dissipation					
					Operating I _{CC} (mA)				Standby I _{SB2} (μA)	
	Min.	Typ. ^[2]	Max.		f = 1MHz		f = f _{Max}			
					Typ. ^[2]	Max.	Typ. ^[2]	Max.	Typ. ^[2]	Max.
CY62167DV30LL	2.2	3.0	3.6	45	2	4	18.5	37	2.5	22
				55			15	30		
				70			12	25		

Pin Configuration^[3, 4, 5]

**48-ball VFBGA
Top View**

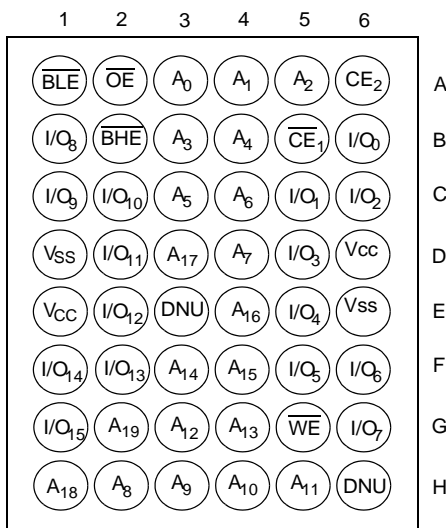

**48-Pin TSOP I (Forward) (1M x 16/ 2M x 8)^[6]
Top View**

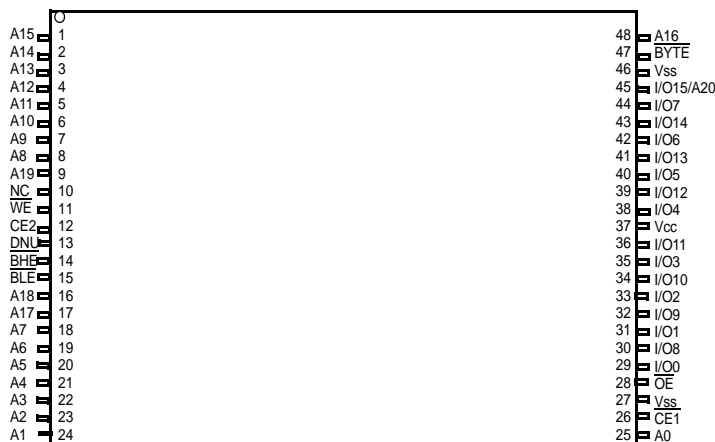

Notes:

- Typical values are included for reference only and are not guaranteed or tested. Typical values are measured at V_{CC} = V_{CC(typ.)}, T_A = 25°C.
- NC pins are not connected on the die.
- DNU pins have to be left floating.
- Ball H6 for the FBGA package can be used to upgrade to a 32M density.
- The BYTE pin in the 48-TSOP I package has to be tied to V_{CC} to use the device as a 1M X 16 SRAM. The 48-TSOP I package can also be used as a 2M X 8 SRAM by tying the BYTE signal to V_{SS}. In the 2M x 8 configuration, Pin 45 is A20, while BHE, BLE and I/O8 to I/O14 pins are not used (DNU).



CY62167DV30 MoBL[®]

Maximum Ratings

(Above which the useful life may be impaired. For user guidelines, not tested.)

Storage Temperature	-65°C to +150°C
Ambient Temperature with Power Applied	-55°C to +125°C
Supply Voltage to Ground Potential	-0.2V to V _{CC} + 0.3V
DC Voltage Applied to Outputs in High-Z State ^[7, 8]	-0.2V to V _{CC} + 0.3V
DC Input Voltage ^[7, 8]	-0.2V to V _{CC} + 0.3V

Output Current into Outputs (LOW)	20 mA
Static Discharge Voltage	> 2001V (per MIL-STD-883, Method 3015)
Latch-up Current	> 200 mA

Operating Range

Device	Range	Ambient Temperature	V _{CC} ^[9]
CY62167DV30LL	Industrial	-40°C to +85°C	2.20V to 3.60V

Electrical Characteristics Over the Operating Range

Parameter	Description	Test Conditions	CY62167DV30-45			CY62167DV30-55			CY62167DV30-70			Unit
			Min.	Typ. ^[2]	Max.	Min.	Typ. ^[2]	Max.	Min.	Typ. ^[2]	Max.	
V _{OH}	Output HIGH Voltage	I _{OH} = -0.1 mA, V _{CC} = 2.20V	2.0			2.0			2.0			V
		I _{OH} = -1.0 mA, V _{CC} = 2.70V	2.4			2.4			2.4			
V _{OL}	Output LOW Voltage	I _{OL} = 0.1 mA, V _{CC} = 2.20V			0.4			0.4			0.4	V
		I _{OL} = 2.1mA, V _{CC} = 2.70V										
V _{IH}	Input HIGH Voltage	V _{CC} = 2.2V to 2.7V	1.8		V _{CC} +0.3V	1.8		V _{CC} +0.3V	1.8		V _{CC} +0.3V	V
		V _{CC} = 2.7V to 3.6V	2.2			2.2			2.2			
V _{IL}	Input LOW Voltage	V _{CC} = 2.2V to 2.7V	-0.3		0.6	-0.3		0.6	-0.3		0.6	V
		V _{CC} = 2.7V to 3.6V			0.8			0.8			0.8	
I _{IX}	Input Leakage Current	GND ≤ V _I ≤ V _{CC}	-1		+1	-1		+1	-1		+1	μA
I _{OZ}	Output Leakage Current	GND ≤ V _O ≤ V _{CC} , Output Disabled	-1		+1	-1		+1	-1		+1	μA
I _{CC}	V _{CC} Operating Supply Current	V _{CC} = V _{CC(max)} , I _{OUT} = 0 mA, CMOS levels		18.5	37		15	30		12	25	mA
		f = f _{Max} = 1/t _{RC}										
		f = 1 MHz		2	4		2	4		2	4	
I _{SB1}	Automatic CE Power-down Current — CMOS Inputs	$\overline{CE}_1 \geq V_{CC} - 0.2V$ or $CE_2 \leq 0.2V$, V _{IN} ≥ V _{CC} - 0.2V, V _{IN} ≤ 0.2V, f = f _{Max} (Address and Data Only), f = 0 (\overline{OE} , \overline{WE} , \overline{BHE} , \overline{BLE}), V _{CC} = 3.60V		2.5	22		2.5	22		2.5	22	μA
I _{SB2}	Automatic CE Power-down Current — CMOS Inputs	$\overline{CE}_1 \geq V_{CC} - 0.2V$ or $CE_2 \leq 0.2V$, V _{IN} ≥ V _{CC} - 0.2V or V _{IN} ≤ 0.2V, f = 0, V _{CC} = 3.60V		2.5	22		2.5	22		2.5	22	μA

Notes:

7. V_{IL(min)} = -2.0V for pulse durations less than 20 ns.
8. V_{IH(max)} = V_{CC} + 0.75V for pulse durations less than 20 ns.
9. Full Device AC operation requires linear V_{CC} ramp from 0 to V_{CC(min)} and V_{CC} must be stable at V_{CC(min)} for 500 μs.



CY62167DV30 MoBL[®]

Capacitance^[10, 11]

Parameter	Description	Test Conditions	Max.	Unit
C _{IN}	Input Capacitance	T _A = 25°C, f = 1 MHz, V _{CC} = V _{CC(typ)}	8	pF
C _{OUT}	Output Capacitance		10	pF

Thermal Resistance^[10]

Parameter	Description	Test Conditions	VFBGA	TSOP I	Unit
Θ _{JA}	Thermal Resistance (Junction to Ambient)	Still Air, soldered on a 3 × 4.5 inch, 2-layer printed circuit board	55	60	°C/W
Θ _{JC}	Thermal Resistance (Junction to Case)		16	4.3	°C/W

AC Test Loads and Waveforms^[12]

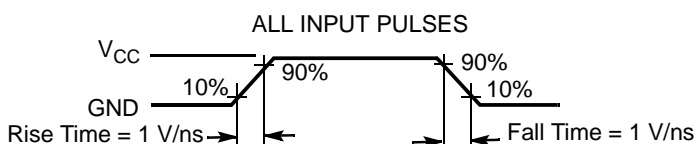
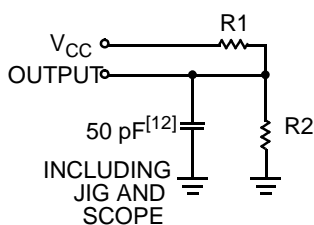

Equivalent to: THEVENIN EQUIVALENT



Parameters	2.5V	3.0V	Unit
R ₁	16667	1103	Ω
R ₂	15385	1554	Ω
R _{TH}	8000	645	Ω
V _{TH}	1.20	1.75	V

Data Retention Characteristics (Over the Operating Range)

Parameter	Description	Conditions	Min.	Typ. ^[2]	Max.	Unit
V _{DR}	V _{CC} for Data Retention		1.5			V
I _{CCDR}	Data Retention Current	V _{CC} = 1.5V CE ₁ ≥ V _{CC} - 0.2V, CE ₂ ≤ 0.2V, V _{IN} ≥ V _{CC} - 0.2V or V _{IN} ≤ 0.2V			10	μA
t _{CDR} ^[10]	Chip Deselect to Data Retention Time		0			ns
t _R ^[13]	Operation Recovery Time		t _{RC}			ns

Notes:

10. Tested initially and after any design or process changes that may affect these parameters.

11. This applies for all packages.

12. Test condition for the 45 ns part is with a load capacitance of 30 pF.

13. Full device operation requires linear V_{CC} ramp from V_{DR} to V_{CC(min.)} ≥ 100 μs or stable at V_{CC(min.)} ≥ 100 μs.



CY62167DV30 MoBL[®]

Data Retention Waveform^[14]

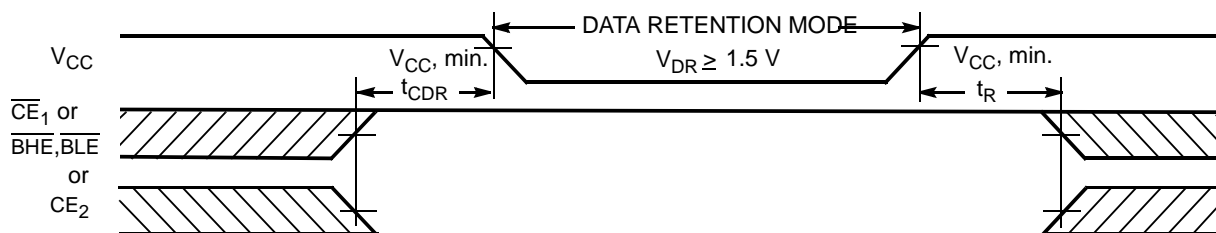

Switching Characteristics Over the Operating Range^[15]

Parameter	Description	45 ns ^[12]		55 ns		70 ns		Unit
		Min.	Max.	Min.	Max.	Min.	Max.	
Read Cycle								
t _{RC}	Read Cycle Time	45		55		70		ns
t _{AA}	Address to Data Valid		45		55		70	ns
t _{OHA}	Data Hold from Address Change	10		10		10		ns
t _{ACE}	CE ₁ LOW and CE ₂ HIGH to Data Valid		45		55		70	ns
t _{DOE}	OE LOW to Data Valid		25		25		35	ns
t _{LZOE}	OE LOW to LOW Z ^[16]	5		5		5		ns
t _{HZOE}	OE HIGH to High Z ^[16, 17]		15		20		25	ns
t _{LZCE}	CE ₁ LOW and CE ₂ HIGH to Low Z ^[16]	10		10		10		ns
t _{HZCE}	CE ₁ HIGH and CE ₂ LOW to High Z ^[16, 17]		20		20		25	ns
t _{PU}	CE ₁ LOW and CE ₂ HIGH to Power-up	0		0		0		ns
t _{PD}	CE ₁ HIGH and CE ₂ LOW to Power-down		45		55		70	ns
t _{DBE}	BLE/BHE LOW to Data Valid		45		55		70	ns
t _{LZBE}	BLE/BHE LOW to Low Z ^[16]	10		10		10		ns
t _{HZBE}	BLE/BHE HIGH to HIGH Z ^[16, 17]		15		20		25	ns
Write Cycle^[18]								
t _{WC}	Write Cycle Time	45		55		70		ns
t _{SCE}	CE ₁ LOW and CE ₂ HIGH to Write End	40		40		60		ns
t _{AW}	Address Set-Up to Write End	40		40		60		ns
t _{HA}	Address Hold from Write End	0		0		0		ns
t _{SA}	Address Set-Up to Write Start	0		0		0		ns
t _{PWE}	WE Pulse Width	35		40		45		ns
t _{BW}	BLE/BHE LOW to Write End	40		40		60		ns
t _{SD}	Data Set-Up to Write End	25		25		30		ns
t _{HD}	Data Hold from Write End	0		0		0		ns
t _{HZWE}	WE LOW to High-Z ^[16, 17]		15		20		25	ns
t _{LZWE}	WE HIGH to Low-Z ^[16]	10		10		10		ns

Notes:

14. BHE, BLE is the AND of both BHE and BLE. Chip can be deselected by either disabling the chip enable signals or by disabling both BHE and BLE.
15. Test conditions for all parameters other than Tri-state parameters assume signal transition time of 1 ns/V, timing reference levels of V_{CC(typ)}/2, input pulse levels of 0 to V_{CC(typ)}, and output loading of the specified I_{OL}/I_{OH} as shown in the "AC Test Loads and Waveforms" section.
16. At any given temperature and voltage condition, t_{HZCE} is less than t_{LZCE}, t_{HZBE} is less than t_{LZBE}, t_{HZOE} is less than t_{LZOE}, and t_{HZWE} is less than t_{LZWE} for any given device.
17. t_{HZOE}, t_{HZCE}, t_{HZBE}, and t_{HZWE} transitions are measured when the outputs enter a high impedance state.
18. The internal Write time of the memory is defined by the overlap of WE, CE₁ = V_{IL}, BHE and/or BLE = V_{IL}, and CE₂ = V_{IH}. All signals must be ACTIVE to initiate a write and any of these signals can terminate a write by going INACTIVE. The data input set-up and hold timing should be referenced to the edge of the signal that terminates the Write.



CY62167DV30 MoBL®

Switching Waveforms

Read Cycle 1 (Address Transition Controlled)^[19, 20]

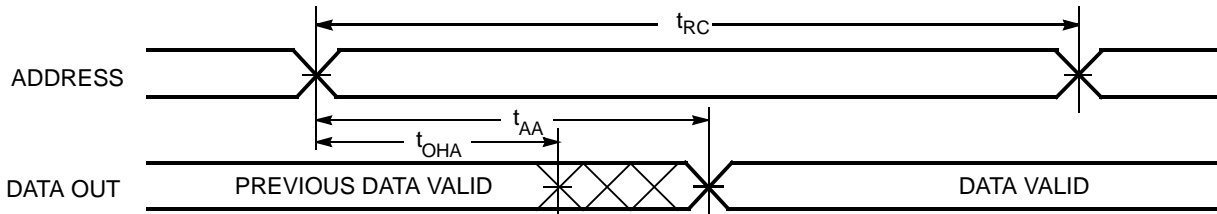

Read Cycle 2 (\overline{OE} Controlled)^[20, 21]

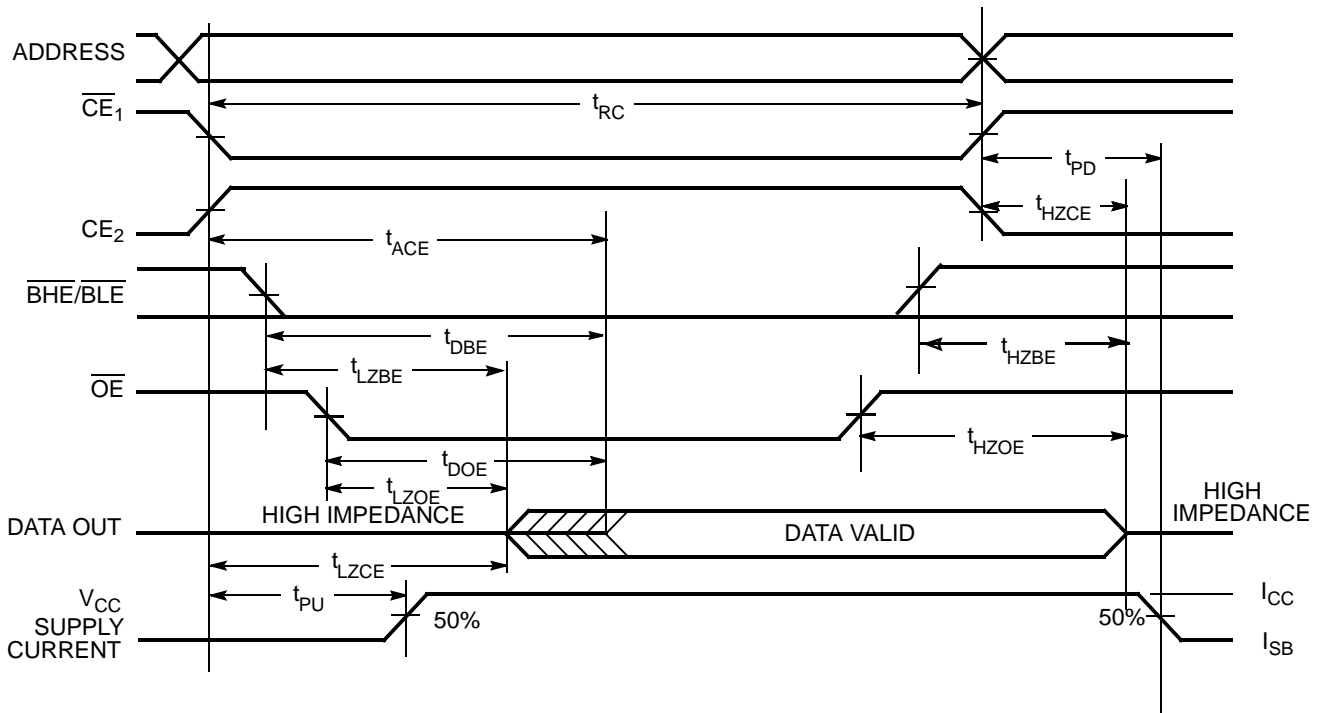

- Notes:**
 19. The device is continuously selected. \overline{OE} , \overline{CE}_1 , \overline{BHE} and/or $\overline{BLE} = V_{IL}$, and $CE_2 = V_{IH}$.
 20. \overline{WE} is HIGH for read cycle.
 21. Address valid prior to or coincident with \overline{CE}_1 , \overline{BHE} , \overline{BLE} transition LOW and CE_2 transition HIGH.



CY62167DV30 MoBL®

Switching Waveforms (continued)

Write Cycle 1 (\overline{WE} Controlled)^[18, 22, 23, 24]

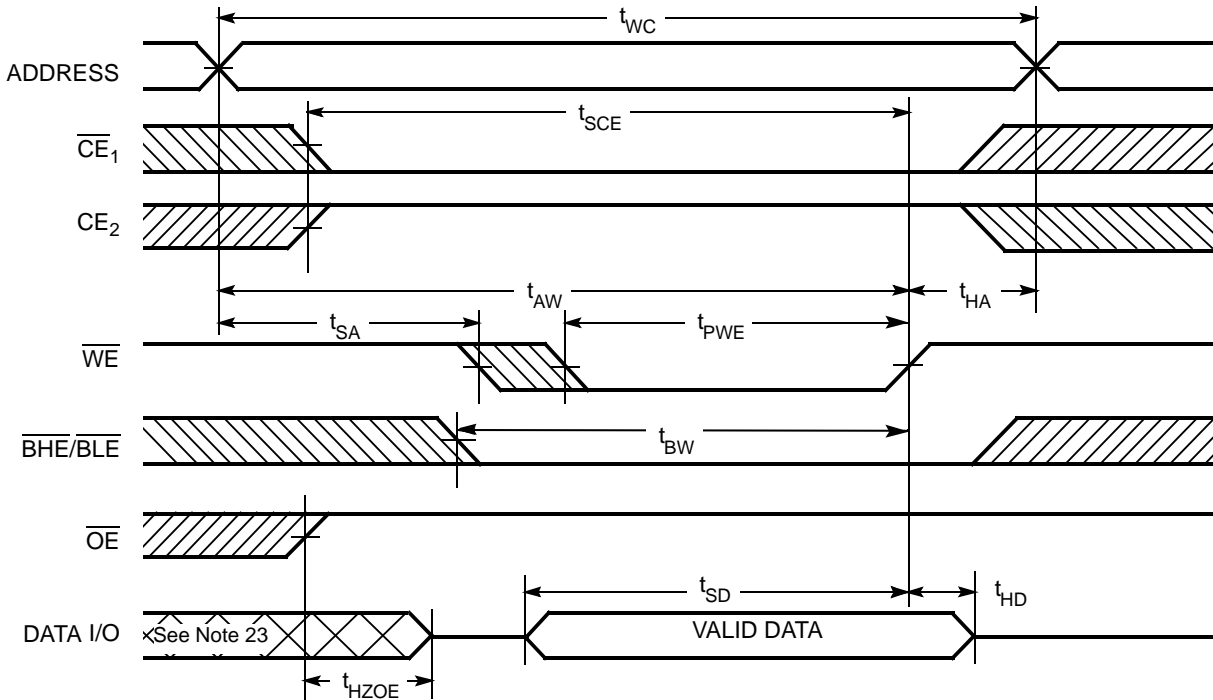

Notes:

- 22. Data I/O is high-impedance if $\overline{OE} = V_{IH}$.
- 23. If \overline{CE}_1 goes HIGH and \overline{CE}_2 goes LOW simultaneously with $\overline{WE} = V_{IH}$, the output remains in a high-impedance state.
- 24. During this period, the I/Os are in output state and input signals should not be applied.

Switching Waveforms (continued)

Write Cycle 2 (\overline{CE}_1 or CE_2 Controlled)^[18, 22, 23, 24]

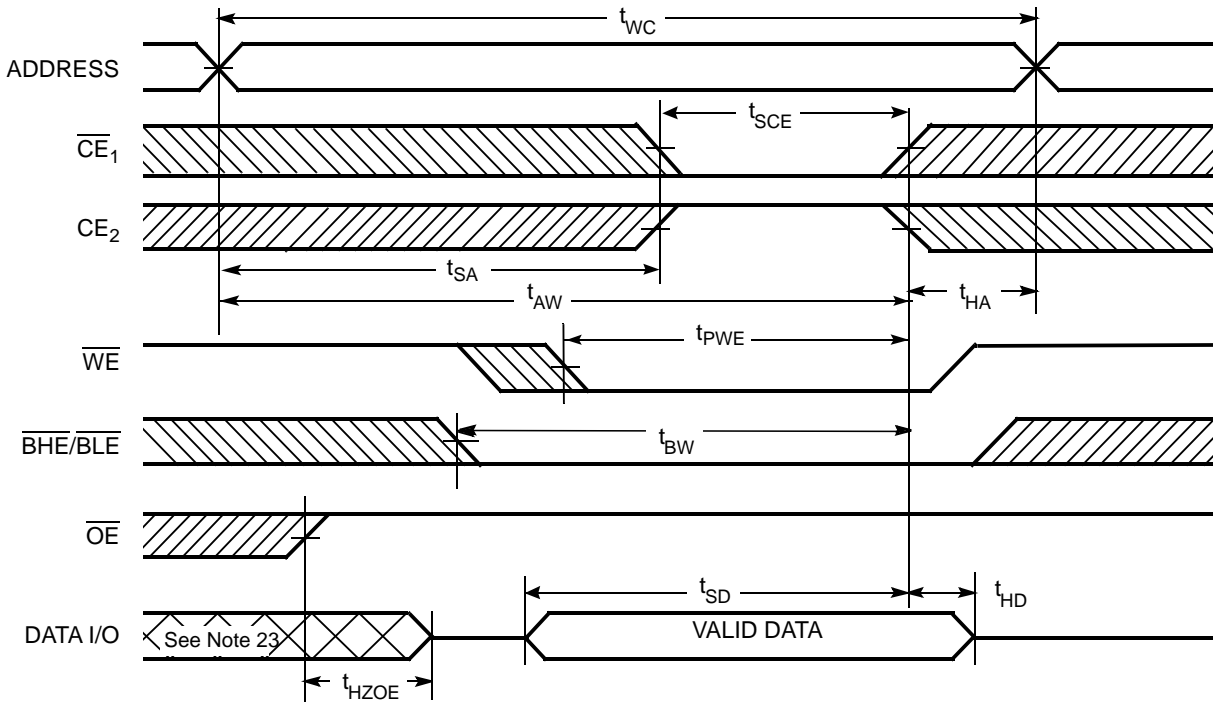

Write Cycle 3 (\overline{WE} Controlled, \overline{OE} LOW)^[23, 24]

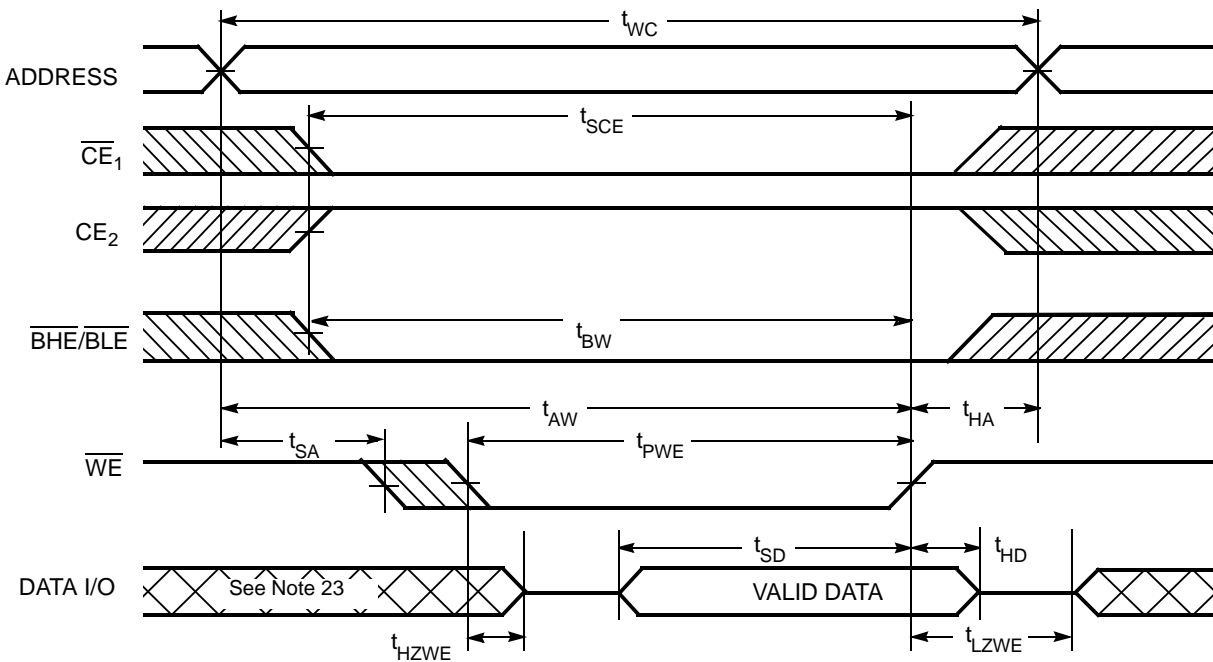



CY62167DV30 MoBL®

Switching Waveforms (continued)

Write Cycle 4 ($\overline{\text{BHE}}/\overline{\text{BLE}}$ Controlled, $\overline{\text{OE}}$ LOW)^[23, 24]

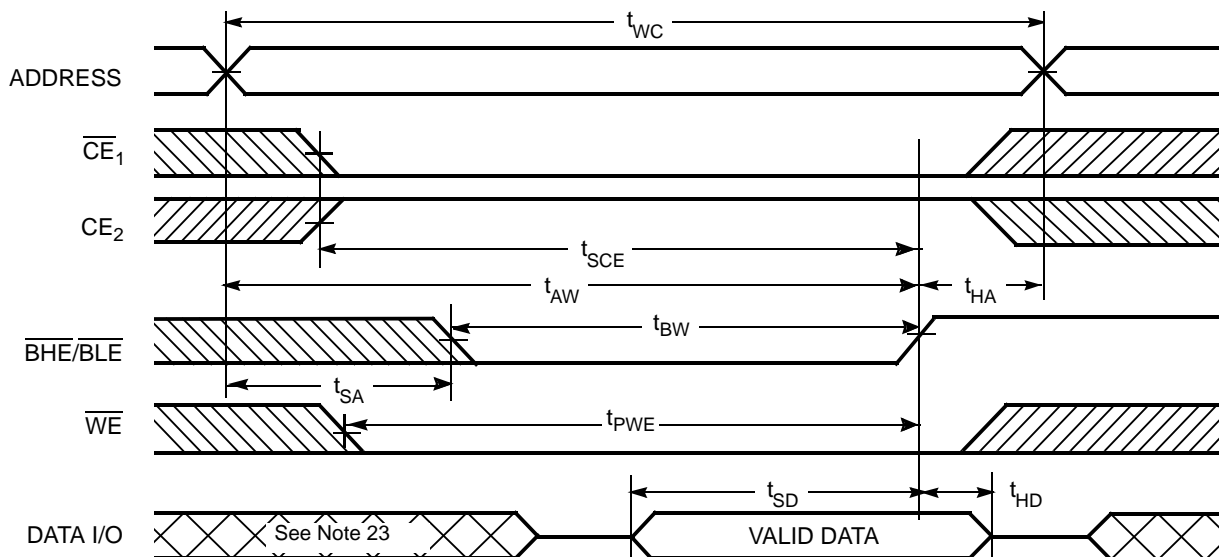

Truth Table

$\overline{\text{CE}}_1$	CE_2	$\overline{\text{WE}}$	$\overline{\text{OE}}$	$\overline{\text{BHE}}$	$\overline{\text{BLE}}$	Inputs/Outputs	Mode	Power
H	X	X	X	X	X	High Z	Deselect/Power-Down	Standby (I_{SB})
X	L	X	X	X	X	High Z	Deselect/Power-Down	Standby (I_{SB})
X	X	X	X	H	H	High Z	Deselect/Power-Down	Standby (I_{SB})
L	H	H	L	L	L	Data Out (I/O_0 - I/O_{15})	Read	Active (I_{CC})
L	H	H	L	H	L	High Z (I/O_8 - I/O_{15}); Data Out (I/O_0 - I/O_7)	Read	Active (I_{CC})
L	H	H	L	L	H	Data Out (I/O_8 - I/O_{15}); High Z (I/O_0 - I/O_7)	Read	Active (I_{CC})
L	H	L	X	L	L	Data In (I/O_0 - I/O_{15})	Write	Active (I_{CC})
L	H	L	X	H	L	High Z (I/O_8 - I/O_{15}); Data In (I/O_0 - I/O_7)	Write	Active (I_{CC})
L	H	L	X	L	H	Data In (I/O_8 - I/O_{15}); High Z (I/O_0 - I/O_7)	Write	Active (I_{CC})
L	H	H	H	L	H	High Z	Output Disabled	Active (I_{CC})
L	H	H	H	H	L	High Z	Output Disabled	Active (I_{CC})
L	H	H	H	L	L	High Z	Output Disabled	Active (I_{CC})

Ordering Information

Speed (ns)	Ordering Code	Package Diagram	Package Type	Operating Range
45	CY62167DV30LL-45ZXI	51-85183	48-pin TSOP I (12 x 18.4 x 1 mm) (Pb-free)	Industrial
55	CY62167DV30LL-55BVI	51-85178	48-ball Fine Pitch BGA (8 x 9.5 x 1 mm)	
	CY62167DV30LL-55BVXI		48-ball Fine Pitch BGA (8 x 9.5 x 1 mm) (Pb-free)	
	CY62167DV30LL-55ZI	51-85183	48-pin TSOP I (12 x 18.4 x 1 mm)	
	CY62167DV30LL-55ZXI		48-pin TSOP I (12 x 18.4 x 1 mm) (Pb-free)	
70	CY62167DV30LL-70BVI	51-85178	48-ball Fine Pitch BGA (8 x 9.5 x 1 mm)	

Please contact your local Cypress sales representative for availability of these parts

Package Diagrams

48-ball VFBGA (8 x 9.5 x 1 mm) (51-85178)

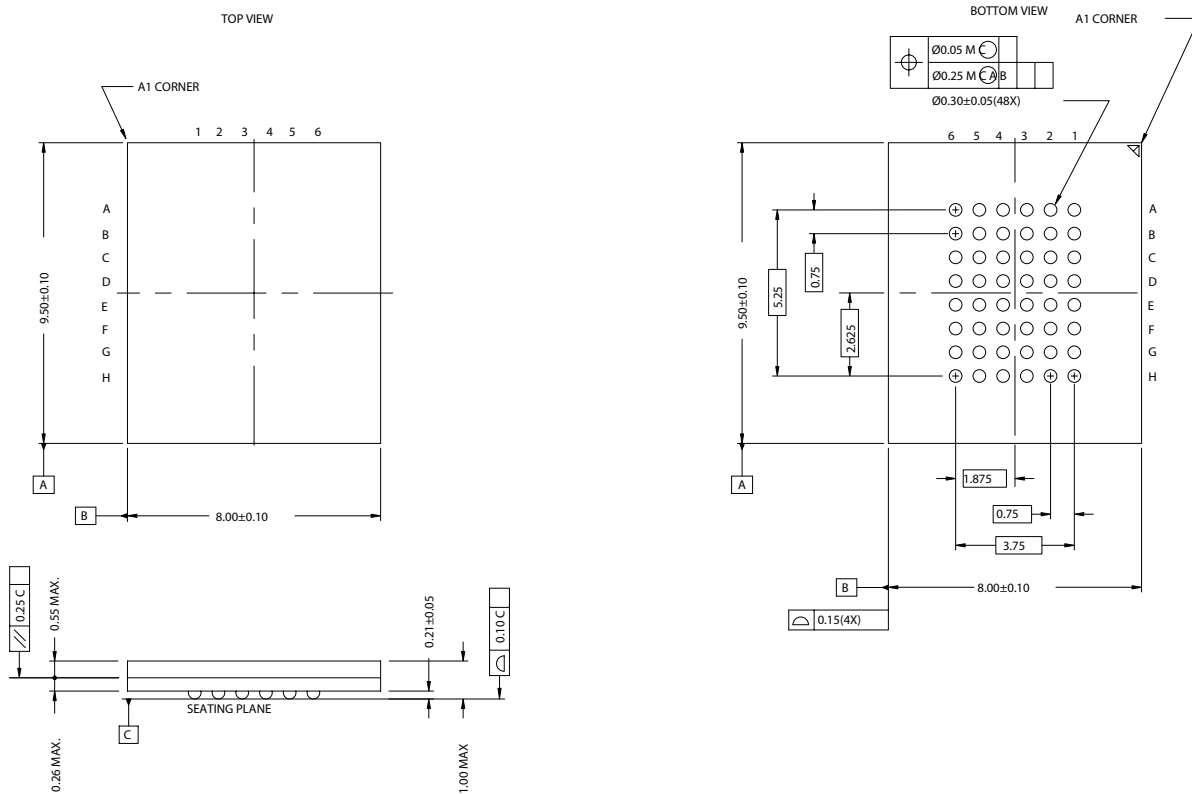

51-85178-**

Package Diagrams (continued)

48-pin TSOP I (12 x 18.4 x 1mm) (51-85183)

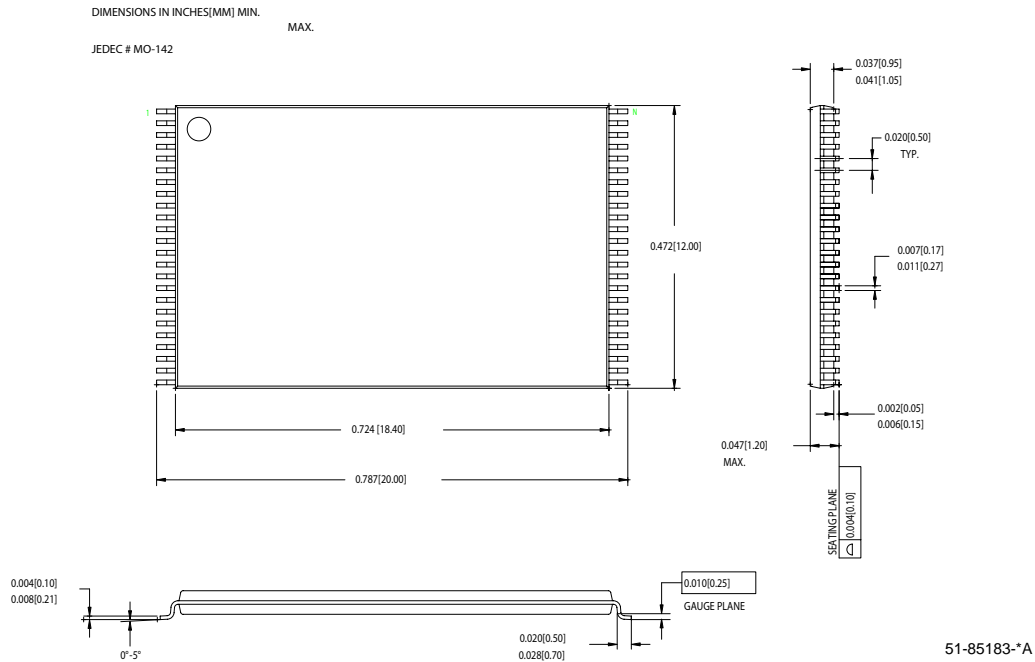

MoBL is a registered trademark and More Battery Life is a trademark of Cypress Semiconductor Corporation. All product and company names mentioned in this document may be the trademarks of their respective holders.



CY62167DV30 MoBL®

Document History Page

Document Title: CY62167DV30 MoBL®, 16-Mbit (1M x 16) Static RAM Document Number: 38-05328				
REV.	ECN NO.	Issue Date	Orig. of Change	Description of Change
**	118408	09/30/02	GUG	New Data Sheet
*A	123692	02/11/03	DPM	Changed Advanced to Preliminary Added package diagram
*B	126555	04/25/03	DPM	Minor change: Changed Sunset Owner from DPM to HRT
*C	127841	09/10/03	XRJ	Added 48 TSOP I package
*D	205701		AJU	Changed BYTE pin usage description for 48 TSOPI package
*E	238050	See ECN	KKV/AJU	Replaced 48-ball VFPGA package diagram; Modified Package Name in Ordering Information table from BV48A to BV48B
*F	304054	See ECN	PCI	Added 45-ns Speed Bin in AC, DC and Ordering Information tables Added Footnote #12 on page #4 Added Pb-free packages on page # 10
*G	492895	See ECN	VKN	Modified datasheet to explain x8 configurability Removed L power bin from the product offering Updated Ordering Information Table