

Excellent Integrated System Limited

Stocking Distributor

Click to view price, real time Inventory, Delivery & Lifecycle Information:

[Infineon Technologies](#)

[BFS 466L6 E6327](#)

For any questions, you can email us directly:

sales@integrated-circuit.com



BFS466L6

NPN Silicon RF TWIN Transistor*

- Low voltage/ low current applications
- Ideal for VCO modules and low noise amplifiers
- World's smallest SMD 6-pin leadless package
- Built in 2 transistors (TR1: die as BFR460L3,
TR2: die as BFR360L3)
- Low noise figure: TR1: 1.1dB at 1.8 GHz
TR2: 1.0 dB at 1.8 GHz
- TR1 with excellent ESD performance
typical value > 1500 V (HBM)
- Pb-free (RoHS compliant) package¹⁾
- Qualified according AEC Q101

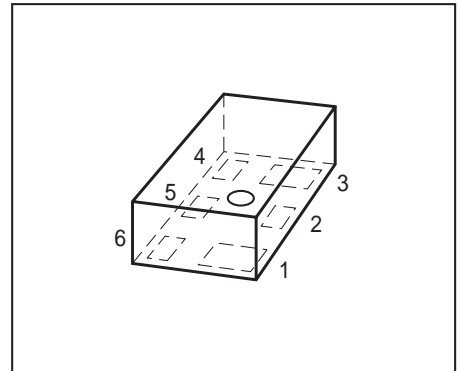

* Short term description

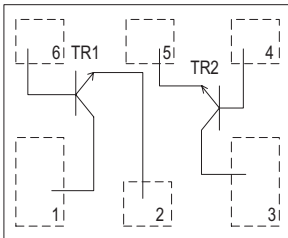

ESD (Electrostatic discharge) sensitive device, observe handling precaution!

Type	Marking	Pin Configuration						Package
BFS466L6	AC	1=C1	2=E1	3=C2	4=B2	5=E2	6=B1	TSLP-6-1

¹Pb-containing package may be available upon special request



BFS466L6

Maximum Ratings

Parameter	Symbol	Value	Unit
Collector-emitter voltage TR1, $T_A > 0\text{ }^\circ\text{C}$ TR1, $T_A \leq 0\text{ }^\circ\text{C}$ TR2, $T_A > 0\text{ }^\circ\text{C}$ TR2, $T_A \leq 0\text{ }^\circ\text{C}$	V_{CEO}	4.5 4.2 6 6	V
Collector-emitter voltage TR1 TR2	V_{CES}	15 15	
Collector-base voltage TR1 TR2	V_{CBO}	15 15	
Emitter-base voltage TR1 TR2	V_{EBO}	1.5 2	
Collector current TR1 TR2	I_C	50 35	mA

BFS466L6
Maximum Ratings

Parameter	Symbol	Value	Unit
Base current	I_B		mA
TR1		5	
TR2		4	
Total power dissipation ¹⁾	P_{tot}		mW
TR1, $T_S \leq 104^\circ\text{C}$		200	
TR2, $T_S \leq 102^\circ\text{C}$		210	
Junction temperature	T_j		$^\circ\text{C}$
TR1		150	
TR2		150	
Ambient temperature	T_A		
TR1		-65 ... 150	
TR2		-65 ... 150	
Storage temperature	T_{stg}		
TR1		-65 ... 150	
TR2		-65 ... 150	

Thermal Resistance

Parameter	Symbol	Value	Unit
Junction - soldering point ²⁾	R_{thJS}		K/W
TR1		≤ 230	
TR2		≤ 230	

¹ T_S is measured on the collector lead at the soldering point to the pcb

²For calculation of R_{thJA} please refer to Application Note Thermal Resistance



BFS466L6

Electrical Characteristics at $T_A = 25^\circ\text{C}$, unless otherwise specified

Parameter	Symbol	Values			Unit
		min.	typ.	max.	
DC Characteristics					
Collector-emitter breakdown voltage TR1, $I_C = 1\text{ mA}$, $I_B = 0$ TR2, $I_C = 1\text{ mA}$, $I_B = 0$	$V_{(BR)CEO}$	4.5 6	5 9	- -	V
Collector-emitter cutoff current TR1, $V_{CE} = 15\text{ V}$, $V_{BE} = 0$ TR2, $V_{CE} = 15\text{ V}$, $V_{BE} = 0$	I_{CES}	- -	- -	10 10	μA
Collector-base cutoff current TR1, $V_{CB} = 5\text{ V}$, $I_E = 0$ TR2, $V_{CB} = 5\text{ V}$, $I_E = 0$	I_{CBO}	- -	- -	100 100	nA
Emitter-base cutoff current TR1, $V_{EB} = 0,5\text{ V}$, $I_C = 0$ TR2, $V_{EB} = 1\text{ V}$, $I_C = 0$	I_{EBO}	- -	- -	1 1	μA
DC current gain TR1, $I_C = 20\text{ mA}$, $V_{CE} = 3\text{ V}$, Pulse measured TR2, $I_C = 15\text{ mA}$, $V_{CE} = 3\text{ V}$, Pulse measured	h_{FE}	90 90	120 120	160 160	-

BFS466L6
Electrical Characteristics at $T_A = 25^\circ\text{C}$, unless otherwise specified

Parameter	Symbol	Values			Unit
		min.	typ.	max.	
AC Characteristics (verified by random sampling)					
Transition frequency	f_T				GHz
TR1, $I_C = 30\text{ mA}$, $V_{CE} = 3\text{ V}$, $f = 1\text{ GHz}$		16	22	-	
TR2, $I_C = 15\text{ mA}$, $V_{CE} = 3\text{ V}$, $f = 1\text{ GHz}$		11	14	-	
Collector-base capacitance	C_{cb}				pF
TR1, $V_{CB} = 3\text{ V}$, $f = 1\text{ MHz}$, $V_{BE} = 0$, emitter grounded		-	0.29	0.45	
TR2, $V_{CB} = 5\text{ V}$, $f = 1\text{ MHz}$, $V_{BE} = 0$, emitter grounded		-	0.26	0.4	
Collector emitter capacitance	C_{ce}				
TR1, $V_{CE} = 3\text{ V}$, $f = 1\text{ MHz}$, $V_{BE} = 0$, base grounded		-	0.14	-	
TR2, $V_{CE} = 5\text{ V}$, $f = 1\text{ MHz}$, $V_{BE} = 0$, base grounded		-	0.14	-	
Emitter-base capacitance	C_{eb}				
TR1, $V_{EB} = 0.5\text{ V}$, $f = 1\text{ MHz}$, $V_{CB} = 0$, collector grounded		-	0.54	-	
TR2, $V_{EB} = 0.5\text{ V}$, $f = 1\text{ MHz}$, $V_{CB} = 0$, collector grounded		-	0.43	-	

BFS466L6
Electrical Characteristics at TA = 25°C, unless otherwise specified

Parameter	Symbol	Values			Unit
		min.	typ.	max.	
AC Characteristics (verified by random sampling)					
Noise figure	F				dB
TR1, $I_C=5\text{mA}$, $V_{CE} = 3\text{ V}$, $f = 1.8\text{ GHz}$, $Z_S = Z_{\text{Sopt}}$		-	1.1	-	
TR1, $I_C=5\text{mA}$, $V_{CE} = 3\text{ V}$, $f = 3\text{ GHz}$, $Z_S = Z_{\text{Sopt}}$		-	1.4	-	
TR2, $I_C=3\text{mA}$, $V_{CE} = 3\text{ V}$, $f = 1.8\text{ GHz}$, $Z_S = Z_{\text{Sopt}}$		-	1	-	
TR2, $I_C=3\text{mA}$, $V_{CE} = 3\text{ V}$, $f = 3\text{ GHz}$, $Z_S = Z_{\text{Sopt}}$		-	1.4	-	
Power gain, maximum available ¹⁾	G_{ma}				
TR1, $I_C = 20\text{ mA}$, $V_{CE} = 3\text{ V}$, $Z_S=Z_{\text{Sopt}}$, $Z_L=Z_{\text{Lopt}}$, $f = 1.8\text{ GHz}$		-	17	-	
TR1, $I_C = 20\text{ mA}$, $V_{CE} = 3\text{ V}$, $Z_S=Z_{\text{Sopt}}$, $Z_L=Z_{\text{Lopt}}$, $f = 3\text{ GHz}$		-	12	-	
TR2, $I_C = 15\text{ mA}$, $V_{CE} = 3\text{ V}$, $Z_S=Z_{\text{Sopt}}$, $Z_L=Z_{\text{Lopt}}$, $f = 1.8\text{ GHz}$		-	16.5	-	
TR2, $I_C = 15\text{ mA}$, $V_{CE} = 3\text{ V}$, $Z_S=Z_{\text{Sopt}}$, $Z_L=Z_{\text{Lopt}}$, $f = 3\text{ GHz}$		-	11.5	-	
Transducer gain	$ S_{21e} ^2$				
TR1, $I_C = 20\text{ mA}$, $V_{CE} = 3\text{ V}$, $Z_S = Z_L = 50\Omega$, $f = 1.8\text{GHz}$		-	14.5	-	
TR1, $I_C = 20\text{ mA}$, $V_{CE} = 3\text{ V}$, $Z_S = Z_L = 50\Omega$, $f = 3\text{GHz}$		-	10	-	
TR2, $I_C = 15\text{ mA}$, $V_{CE} = 3\text{ V}$, $Z_S = Z_L = 50\Omega$, $f = 1.8\text{GHz}$		-	13.5	-	
TR2, $I_C = 15\text{ mA}$, $V_{CE} = 3\text{ V}$, $Z_S = Z_L = 50\Omega$, $f = 3\text{GHz}$		-	9.5	-	
Third order intercept point at output ²⁾	IP_3				dBm
TR1, $V_{CE}=3\text{V}$, $I_C=20\text{mA}$, $Z_S=Z_L=50\Omega$, $f=1.8\text{GHz}$		-	28	-	
TR2, $V_{CE}=3\text{V}$, $I_C=15\text{mA}$, $Z_S=Z_L=50\Omega$, $f=1.8\text{GHz}$		-	24.5	-	
1dB Compression point, at output	$P_{-1\text{dB}}$				
TR1, $I_C=20\text{mA}$, $V_{CE}=3\text{V}$, $Z_S=Z_L=50\Omega$, $f=1.8\text{GHz}$		-	12	-	
TR1, $I_C=15\text{mA}$, $V_{CE}=3\text{V}$, $Z_S=Z_L=50\Omega$, $f=1.8\text{GHz}$		-	9	-	

¹⁾ $G_{\text{ma}} = |S_{21e}| / |S_{12e}| (k - (k^2 - 1)^{1/2})$
²⁾ IP_3 value depends on termination of all intermodulation frequency components.

Termination used for this measurement is 50Ω from 0.1 MHz to 6 GHz



Package TSLP-6-1

BFS466L6

Package Outline

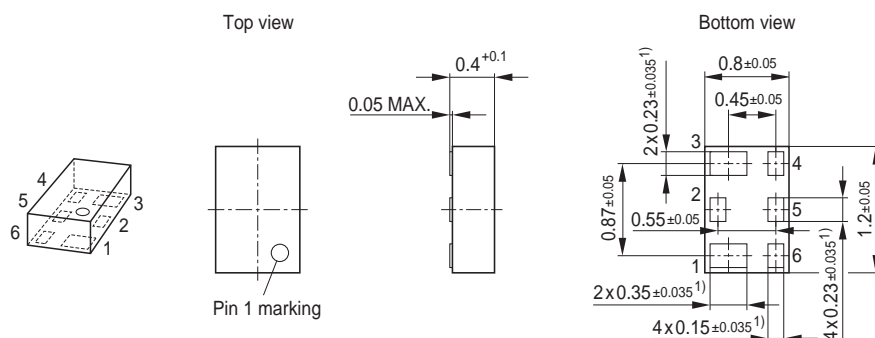

Foot Print

For board assembly information please refer to Infineon website "Packages"

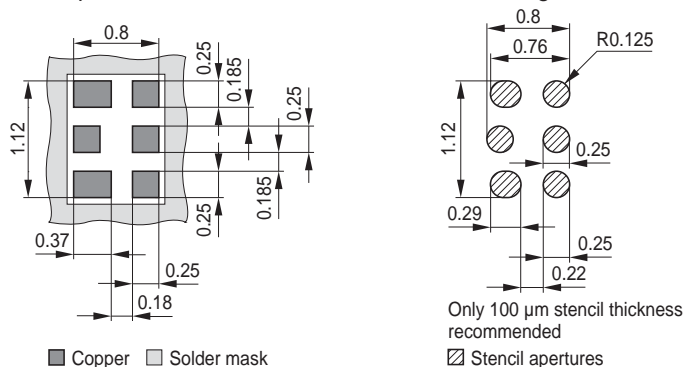

Marking Layout (Example)

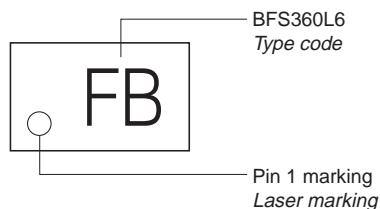

Standard Packing

Reel ø180 mm = 15.000 Pieces/Reel

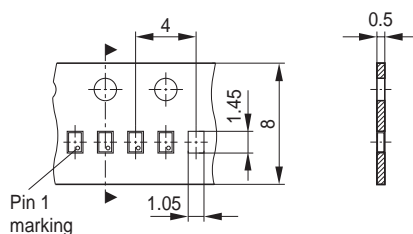



BFS466L6

Edition 2006-02-01

Published by

Infineon Technologies AG

81726 München, Germany

© Infineon Technologies AG 2007.

All Rights Reserved.

Attention please!

The information given in this dokument shall in no event be regarded as a guarantee of conditions or characteristics (“Beschaffenheitsgarantie”). With respect to any examples or hints given herein, any typical values stated herein and/or any information regarding the application of the device, Infineon Technologies hereby disclaims any and all warranties and liabilities of any kind, including without limitation warranties of non-infringement of intellectual property rights of any third party.

Information

For further information on technology, delivery terms and conditions and prices please contact your nearest Infineon Technologies Office (www.infineon.com).

Warnings

Due to technical requirements components may contain dangerous substances. For information on the types in question please contact your nearest Infineon Technologies Office.

Infineon Technologies Components may only be used in life-support devices or systems with the express written approval of Infineon Technologies, if a failure of such components can reasonably be expected to cause the failure of that life-support device or system, or to affect the safety or effectiveness of that device or system.

Life support devices or systems are intended to be implanted in the human body, or to support and/or maintain and sustain and/or protect human life. If they fail, it is reasonable to assume that the health of the user or other persons may be endangered.