

Excellent Integrated System Limited

Stocking Distributor

Click to view price, real time Inventory, Delivery & Lifecycle Information:

[Fairchild Semiconductor](#)
[74LVX174M](#)

For any questions, you can email us directly:

sales@integrated-circuit.com



May 1993
Revised October 2003

74LVX174 Low Voltage Hex D-Type Flip-Flop with Master Reset

General Description

The LVX174 is a high-speed hex D flip-flop. The device is used primarily as a 6-bit edge-triggered storage register. The information on the D inputs is transferred to storage during the LOW-to-HIGH clock transition. The device has a Master Reset to simultaneously clear all flip-flops.

Features

- Input voltage level translation from 5V to 3V
- Ideal for low power/low noise 3.3V applications
- Guaranteed simultaneous switching noise level and dynamic threshold performance

Ordering Code:

Order Number	Package Number	Package Description
74LVX174M	M16A	16-Lead Small Outline Integrated Circuit (SOIC), JEDEC MS-012, 0.150" Narrow
74LVX174SJ	M16D	16-Lead Small Outline Package (SOP), EIAJ TYPE II, 5.3mm Wide
74LVX174MTC	MTC16	16-Lead Thin Shrink Small Outline Package (TSSOP), JEDEC MO-153, 4.4mm Wide

Devices also available in Tape and Reel. Specify by appending the suffix letter "X" to the ordering code.

Logic Symbols

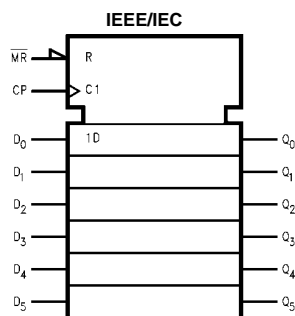
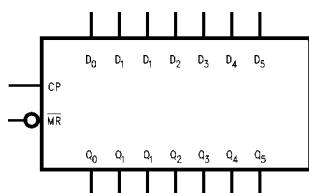

Connection Diagram

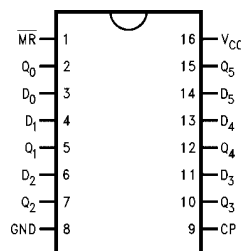

Pin Descriptions

Pin Names	Description
D ₀ -D ₅	Data Inputs
CP	Clock Pulse Input
$\overline{\text{MR}}$	Master Reset Input
Q ₀ -Q ₅	Outputs

74LVX174

Truth Table

Operating Mode	Inputs			Outputs
	\overline{MR}	CP	D_n	Q_n
Reset (Clear)	L	X	X	L
Load '1'	H	↗	H	H
Load '0'	H	↗	L	L

H = HIGH Voltage Level
L = LOW Voltage Level
X = Immaterial
↗ = LOW-to-HIGH Transition

Logic Diagram

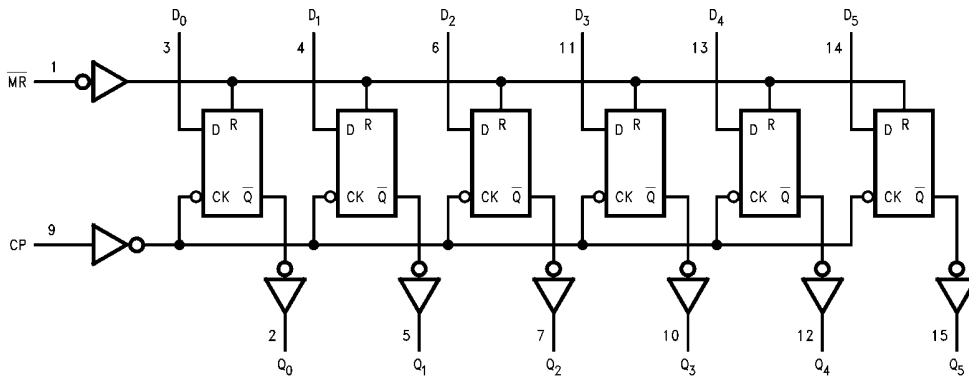

Absolute Maximum Ratings (Note 1)			Recommended Operating Conditions (Note 2)		
Supply Voltage (V_{CC})	-0.5V to +7.0V		Supply Voltage (V_{CC})	2.0V to 3.6V	
DC Input Diode Current (I_{IK})			Input Voltage (V_I)	0V to 5.5V	
$V_I = -0.5V$	-20 mA		Output Voltage (V_O)	0V to V_{CC}	
DC Input Voltage (V_I)	-0.5V to 7V		Operating Temperature (T_A)	-40°C to +85°C	
DC Output Diode Current (I_{OK})			Input Rise and Fall Time ($\Delta t/\Delta V$)	0 ns/V to 100 ns/V	
$V_O = -0.5V$	-20 mA				
$V_O = V_{CC} + 0.5V$	+20 mA				
DC Output Voltage (V_O)	-0.5V to $V_{CC} + 0.5V$				
DC Output Source					
or Sink Current (I_O)	± 25 mA				
DC V_{CC} or Ground Current					
(I_{CC} or I_{GND})	± 50 mA				
Storage Temperature (T_{STG})	-65°C to +150°C				
Power Dissipation (P_D)	180 mW				

Note 1: The "Absolute Maximum Ratings" are those values beyond which the safety of the device cannot be guaranteed. The device should not be operated at these limits. The parametric values defined in the Electrical Characteristics tables are not guaranteed at the absolute maximum ratings. The "Recommended Operating Conditions" table will define the conditions for actual device operation.

Note 2: Unused inputs must be held HIGH or LOW. They may not float.

DC Electrical Characteristics

Symbol	Parameter	V_{CC}	$T_A = +25^\circ C$			$T_A = -40^\circ C$ to $+85^\circ C$		Units	Conditions
			Min	Typ	Max	Min	Max		
V_{IH}	HIGH Level Input Voltage	2.0	1.5			1.5		V	
		3.0	2.0			2.0			
		3.6	2.4			2.4			
V_{IL}	LOW Level Input Voltage	2.0			0.5		0.5	V	
		3.0			0.8		0.8		
		3.6			0.8		0.8		
V_{OH}	HIGH Level Output Voltage	2.0	1.9	2.0		1.9		V	$V_{IN} = V_{IL}$ or V_{IH} $I_{OH} = -50 \mu A$ $I_{OH} = -50 \mu A$ $I_{OH} = -4 mA$
		3.0	2.9	3.0		2.9			
		3.0	2.58			2.48			
V_{OL}	LOW Level Output Voltage	2.0		0.0	0.1		0.1	V	$V_{IN} = V_{IL}$ or V_{IH} $I_{OL} = 50 \mu A$ $I_{OL} = 50 \mu A$ $I_{OL} = 4 mA$
		3.0		0.0	0.1		0.1		
		3.0			0.36		0.44		
I_{IN}	Input Leakage Current	3.6			± 0.1		± 1.0	μA	$V_{IN} = 5.5V$ or GND
I_{CC}	Quiescent Supply Current	3.6			4.0		40.0	μA	$V_{IN} = V_{CC}$ or GND

Noise Characteristics (Note 3)

Symbol	Parameter	V_{CC} (V)	$T_A = 25^\circ C$		Units	C_L (pF)
			Typ	Limit		
V_{OLP}	Quiet Output Maximum Dynamic V_{OL}	3.3	0.3	0.5	V	50
V_{OLV}	Quiet Output Minimum Dynamic V_{OL}	3.3	-0.3	-0.5	V	50
V_{IHD}	Minimum HIGH Level Dynamic Input Voltage	3.3		2.0	V	50
V_{ILD}	Maximum LOW Level Dynamic Input Voltage	3.3		0.8	V	50

Note 3: (Input $t_r = t_f = 3$ ns)

74LVX174

AC Electrical Characteristics										
Symbol	Parameter	V _{CC} (V)	T _A = +25°C			T _A = -40°C to +85°C		Units	C _L (pF)	
			Min	Typ	Max	Min	Max			
t _{PLH}	Propagation Delay Time CP to Q _n	2.7		7.6	14.5	1.0	17.5	ns	15	
t _{PHL}		3.3 ± 0.3		10.1	18.0	1.0	21.0		50	
				5.9	9.3	1.0	11.0		15	
				8.4	12.8	1.0	14.5		50	
t _{PHL}	Propagation Delay MR to Q _n	2.7		7.9	15.0	1.0	18.5	ns	15	
		3.3 ± 0.3			10.4	18.5	1.0		22.0	50
				6.2	9.7	1.0	11.5		15	
				8.7	13.2	1.0	15.0		50	
t _S	Setup Time D _n to CP	2.7	7.5			8.5		ns		
		3.3 ± 0.3	5.0			6.0				
t _H	Hold Time D _n to CP	2.7	0			0				
		3.3 ± 0.3	0			0				
t _{REC}	Removal Time MR to CP	2.7	4.5			4.5		ns		
		3.3 ± 0.3	3.0			3.0				
t _W	Clock Pulse Width	2.7	6.5			7.5				
		3.3 ± 0.3	5.0			5.0				
t _W	MR Pulse Width	2.7	6.5			7.5		ns		
		3.3 ± 0.3	5.0			5.0				
f _{MAX}	Maximum Clock Frequency	2.7	65	130		55			MHz	15
			45	60		40				50
		3.3 ± 0.3	115	180		95		15		
			65	95		55		50		
t _{OSLH}	Output to Output	2.7			1.5		1.5	ns	50	
t _{OSHL}	Skew (Note 4)	3.3			1.5		1.5			

Note 4: Parameter guaranteed by design. t_{OSLH} = |t_{PLHm} - t_{PLHn}|, t_{OSHL} = |t_{PHLm} - t_{PHLn}|

Capacitance

Symbol	Parameter	T _A = +25°C			T _A = -40°C to +85°C		Units
		Min	Typ	Max	Min	Max	
C _{IN}	Input Capacitance		4	10		10	pF
C _{PD}	Power Dissipation Capacitance (Note 5)		29				pF

Note 5: C_{PD} is defined as the value of the internal equivalent capacitance which is calculated from the operating current consumption without load.

Average operating current can be obtained by the equation: $I_{CC(opr)} = \frac{C_{PD} \times V_{CC} \times f_{IN} + I_{CC}}{4 \text{ (per F/F)}}$

74LVX174

Physical Dimensions inches (millimeters) unless otherwise noted

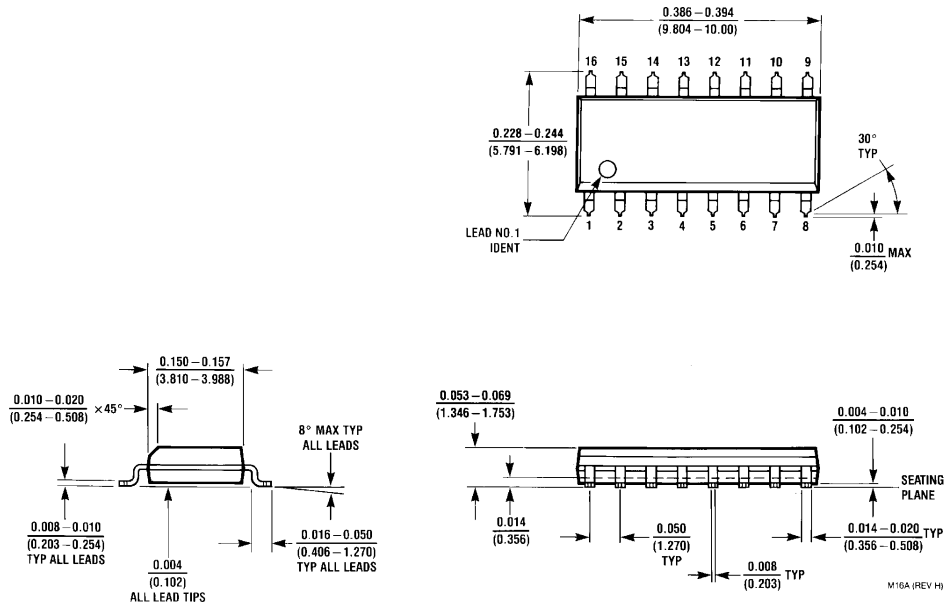

16-Lead Small Outline Integrated Circuit (SOIC), JEDEC MS-012, 0.150" Narrow Package Number M16A

74LVX174

Physical Dimensions inches (millimeters) unless otherwise noted (Continued)

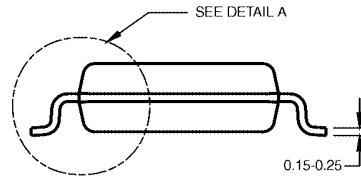
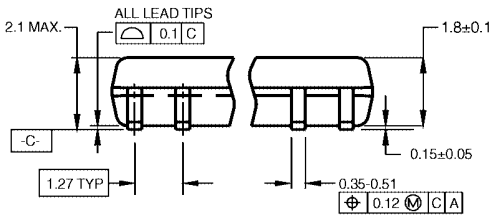
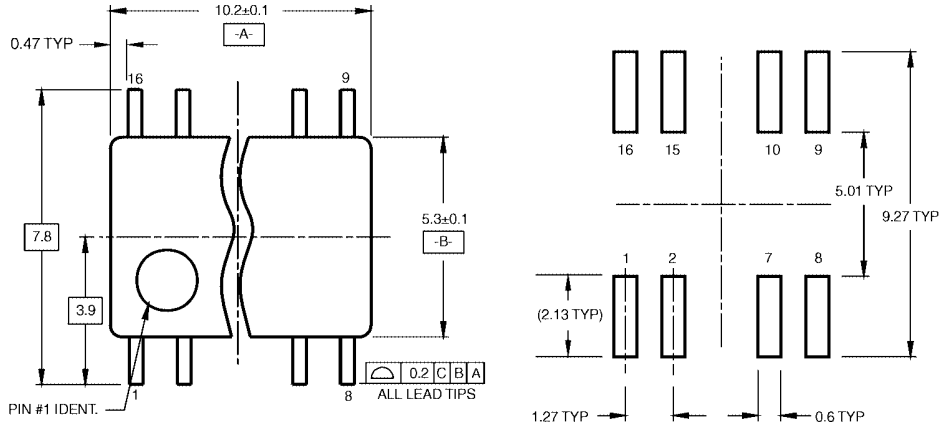

DIMENSIONS ARE IN MILLIMETERS

NOTES:

- A. CONFORMS TO EIAJ EDR-7320 REGISTRATION, ESTABLISHED IN DECEMBER, 1998.
- B. DIMENSIONS ARE IN MILLIMETERS.
- C. DIMENSIONS ARE EXCLUSIVE OF BURRS, MOLD FLASH, AND TIE BAR EXTRUSIONS.

M16DRevB1

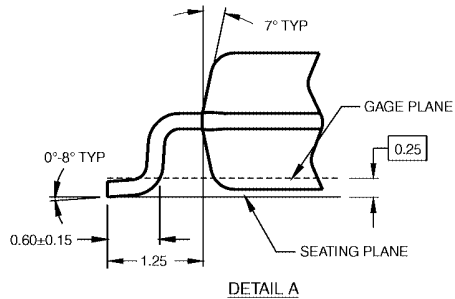

16-Lead Small Outline Package (SOP), EIAJ TYPE II, 5.3mm Wide Package Number M16D

