

Excellent Integrated System Limited

Stocking Distributor

Click to view price, real time Inventory, Delivery & Lifecycle Information:

[Molex Connector Corporation](#)
[0016021125](#)

For any questions, you can email us directly:

sales@integrated-circuit.com

NOTES:

1. TERMINAL TO BE USED IN HOUSINGS 70066-**** AND 70450-****
2. REFER TO PRODUCT SPECIFICATION PS-71851
3. REFER TO MOLEX OPERATIONS AND SERVICE MANUAL FOR CRIMP DETAILS
4. TERMINAL TO BE USED WITH (.064)/.025 SQUARE PINS
5. TERMINAL TO BE USED WITH 22-24 AWG STRANDED WIRE WITH (1.63)/.064 MAX. DIA. INSULATION
6. TERMINALS SUPPLIED LOOSE PER DRAWING PK-70873-0822

PLATING:

.000015 MINIMUM GOLD PLATE IN SELECT AREA
WITH .000075 MINIMUM TIN PLATE IN SELECT AREA OVER NICKEL PLATE OVERALL
*THE PRIMARY SHIPPING CARTON WILL BE LABELED "COMPLIANT TO RoHS DIRECTIVE 2002/95/EC AND ELV ANNEX II OF DIRECTIVE 2000/53/EC". CARTONS WITHOUT THIS LABEL MAY CONTAIN PRODUCT WITH LEAD.

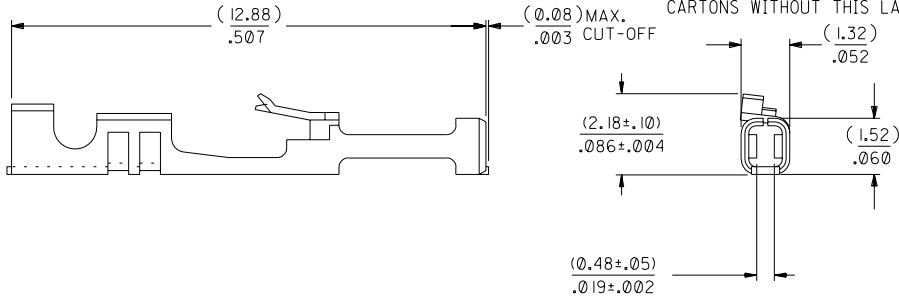
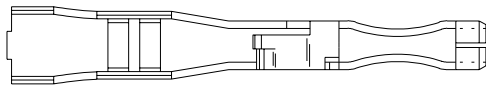

DIMENSIONS SHOWN (METRIC) INCH
UNLESS OTHERWISE SPECIFIED
TOLERANCES: ANGULAR ± 1/2°

| | INCH | METRIC |
|---------|--------|--------|
| 3 PLACE | ± .010 | --- |
| 2 PLACE | ± .014 | ± 0.25 |
| 1 PLACE | --- | ± 0.35 |

DRAFT WHERE APPLICABLE MUST REMAIN WITHIN DIMENSIONS

| | |
|------------------|--------------------|
| DRWG. BY: RWHITE | CHK'D. BY: DMORGAN |
| APP'D: SMILLER | SCALE: 10: 1 |

REVISION SYMBOLS: ▽ = 0, ▽ = 0, REVISE ONLY ON CAD SYSTEM

TITLE: TERMINAL-BOX/CRIMP HIGH FORCE CONTACT

MOLEX INCORPORATED
LITTLELILL. 68532 U.S.A.
SHEET NO. 1 DATE 04/06/21

PART NO. 016-02-1125 DRWG. NO. SD-71851-0224

THIS DRAWING CONTAINS INFORMATION THAT IS PROPRIETARY TO MOLEX INC. AND SHOULD NOT BE USED WITHOUT WRITTEN PERMISSION. DIV. DA SIZE B

| | | | | | | | | | |
|------|---|-----------|---|------|--|-----------|---|---|---|
| 10 | 9 | 8 | 7 | 6 | 5 | 4 | 3 | 2 | 1 |
| | | | | A | INITIAL RELEASE UCP2004-2560 RWHITE 04/06/21 | | | | |
| LTR. | | REVISIONS | | LTR. | | REVISIONS | | | |