

## Excellent Integrated System Limited

Stocking Distributor

Click to view price, real time Inventory, Delivery & Lifecycle Information:

[Maxim Integrated](#)  
[MAX705CPA](#)

For any questions, you can email us directly:  
[sales@integrated-circuit.com](mailto:sales@integrated-circuit.com)

## MAX705–MAX708/MAX813L

## Low-Cost, $\mu$ P Supervisory Circuits

### General Description

The MAX705–MAX708/MAX813L microprocessor ( $\mu$ P) supervisory circuits reduce the complexity and number of components required to monitor power-supply and battery functions in  $\mu$ P systems. These devices significantly improve system reliability and accuracy compared to separate ICs or discrete components.

The MAX705/MAX706/MAX813L provide four functions:

- 1) A reset output during power-up, power-down, and brownout conditions.
- 2) An independent watchdog output that goes low if the watchdog input has not been toggled within 1.6 seconds.
- 3) A 1.25V threshold detector for power-fail warning, low-battery detection, or for monitoring a power supply other than +5V.
- 4) An active-low manual-reset input.

The MAX707/MAX708 are the same as the MAX705/MAX706, except an active-high reset is substituted for the watchdog timer. The MAX813L is the same as the MAX705, except RESET is provided instead of  $\overline{\text{RESET}}$ .

Two supply-voltage monitor levels are available: The MAX705/MAX707/MAX813L generate a reset pulse when the supply voltage drops below 4.65V, while the MAX706/MAX708 generate a reset pulse below 4.40V. All four parts are available in 8-pin DIP, SO, and  $\mu$ MAX<sup>®</sup> packages.

### Applications

- Computers
- Controllers
- Intelligent Instruments
- Critical  $\mu$ P Power Monitoring

*Pin Configurations appear at end of data sheet.*

*$\mu$ MAX is a registered trademark of Maxim Integrated Products, Inc.*

### Benefits and Features

- Supervisory-Function Integration Significantly Improves System Reliability While Reducing Board Space
  - $\mu$ MAX Package
  - Guaranteed RESET Valid at  $V_{CC} = 1V$ 
    - 200ms Reset Pulse Width
    - Debounced TTL/CMOS-Compatible Manual-Reset Input
    - Active-High Reset Output (MAX707/MAX708/MAX813L)
  - Precision-Supply Voltage Monitor
    - 4.65V (MAX705/MAX707/MAX813L)
    - 4.40V (MAX706/MAX708)
  - Voltage Monitor for Power-Fail or Low-Battery Warning

### Ordering Information

PART	TEMP RANGE	PIN-PACKAGE
MAX705CPA	0°C to +70°C	8 Plastic DIP
MAX705CSA	0°C to +70°C	8 SO
MAX705CUA	0°C to +70°C	8 $\mu$ MAX
MAX705C/D	0°C to +70°C	Dice*

\*Dice are specified at  $T_A = +25^\circ\text{C}$ .

\*\*Contact factory for availability and processing to MIL-STD-883. Devices in PDIP, SO, and  $\mu$ MAX packages are available in both leaded and lead(Pb)-free/RoHS-compliant packaging. Specify lead-free by adding the + symbol at the end of the part number when ordering.

Lead-free packaging is not available for CERDIP packages.

*Ordering Information continued at end of data sheet.*

### Typical Operating Circuit

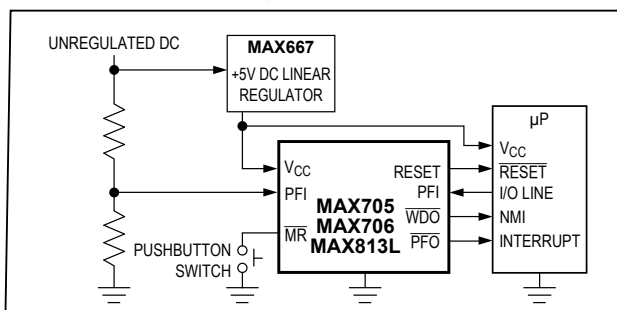

## MAX705–MAX708/MAX813L

## MAX705–MAX708/MAX813L Low-Cost, $\mu$ P Supervisory Circuits

### Absolute Maximum Ratings

Terminal Voltage (with respect to GND)		CERDIP (derate 8.00mW/°C above +70°C).....	640mW
$V_{CC}$ .....	-0.3V to 6.0V	Operating Temperature Ranges	
All Other Inputs (Note 1) .....	-0.3V to ( $V_{CC} + 0.3V$ )	MAX70_C_, MAX813LC_ .....	0°C to +70°C
Input Current		MAX70_E_, MAX813LE_ .....	-40°C to +85°C
$V_{CC}$ .....	20mA	MAX70_MJA.....	-55°C to +125°C
GND .....	20mA	Storage Temperature Range .....	-65°C to +160°C
Output Current (all outputs).....	20mA	Lead Temperature (soldering, 10s) .....	+300°C
Continuous Power Dissipation ( $T_A = +70^\circ\text{C}$ )		Soldering Temperature (reflow)	
Plastic DIP (derate 9.09mW/°C above +70°C).....	727mW	Lead(Pb)-free.....	+260°C
SO (derate 5.88mW/°C above +70°C) .....	471mW	Containing Lead(Pb).....	+240°C
$\mu$ MAX (derate 4.10mW/°C above +70°C) .....	330mW		

**Note 1:** The input-voltage limits on PFI and  $\overline{MR}$  can be exceeded if the input current is less than 10mA.

Stresses beyond those listed under "Absolute Maximum Ratings" may cause permanent damage to the device. These are stress ratings only, and functional operation of the device at these or any other conditions beyond those indicated in the operational sections of the specifications is not implied. Exposure to absolute maximum rating conditions for extended periods may affect device reliability.

### Electrical Characteristics

( $V_{CC} = 4.75V$  to  $5.5V$  for MAX705/MAX707/MAX813L,  $V_{CC} = 4.5V$  to  $5.5V$  for MAX706/MAX708,  $T_A = T_{MIN}$  to  $T_{MAX}$ , unless otherwise noted.)

PARAMETER	SYMBOL	CONDITIONS	MIN	TYP	MAX	UNITS	
Operating Voltage Range	$V_{CC}$	MAX70_C	1.0		5.5	V	
		MAX813LC	1.1		5.5		
		MAX70_E/M, MAX813LE/M	1.2		5.5		
Supply Current	$I_{SUPPLY}$	MAX705C, MAX706C, MAX813LC		150	350	$\mu$ A	
		MAX705E/M, MAX706E/M, MAX813LE/M		150	500		
		MAX707C, MAX708C		50	350		
		MAX707E/M, MAX708E/M		50	500		
Reset Threshold (Note 2)	$V_{RT}$	MAX705, MAX707, MAX813L	4.50	4.65	4.75	V	
		MAX706, MAX708	4.25	4.40	4.50		
Reset Threshold Hysteresis (Note 2)				40		mV	
Reset Pulse Width (Note 2)	$t_{RS}$		140	200	280	ms	
$\overline{RESET}$ Output Voltage		$I_{SOURCE} = 800\mu\text{A}$	$V_{CC} - 1.5$			V	
		$I_{SINK} = 3.2\text{mA}$	0.4				
		MAX70_C, $V_{CC} = 1V$ , $I_{SINK} = 50\mu\text{A}$	0.3				
		MAX70_E/M, $V_{CC} = 1.2V$ , $I_{SINK} = 100\mu\text{A}$	0.3				
RESET Output Voltage		MAX707, MAX708, $I_{SOURCE} = 800\mu\text{A}$	$V_{CC} - 1.5$			V	
		MAX707, MAX708, $I_{SINK} = 1.2\text{mA}$	0.4				
		MAX813LC, $I_{SOURCE} = 4\mu\text{A}$ , $V_{CC} = 1.1V$	0.8				
		MAX813LE/M, $I_{SOURCE} = 4\mu\text{A}$ , $V_{CC} = 1.2V$	0.9				
		MAX813L	$I_{SOURCE} = 800\mu\text{A}$	$V_{CC} - 1.5$			
			$I_{SINK} = 3.2\text{mA}$	0.4			

## MAX705–MAX708/MAX813L

## MAX705–MAX708/MAX813L Low-Cost, $\mu$ P Supervisory Circuits

### Electrical Characteristics (continued)

( $V_{CC}$  = 4.75V to 5.5V for MAX705/MAX707/MAX813L,  $V_{CC}$  = 4.5V to 5.5V for MAX706/MAX708,  $T_A$  =  $T_{MIN}$  to  $T_{MAX}$ , unless otherwise noted.)

PARAMETER	SYMBOL	CONDITIONS	MIN	TYP	MAX	UNITS
Watchdog Timeout Period	$t_{WD}$	MAX705, MAX706, MAX813L	1.00	1.60	2.25	s
WDI Pulse Width	$t_{WP}$	$V_{IL} = 0.4V, V_{IH} = (V_{CC}) (0.8)$	50			ns
WDI Input Threshold	Low	MAX705, MAX706, MAX813L, $V_{CC} = 5V$	0.8			V
	High		3.5			
WDI Input Current		MAX705, MAX706, MAX813L, $V_{CC} = 5V$		50	150	$\mu A$
		MAX705, MAX706, MAX813L, WDI = 0V	-150	-50		
$\overline{WDO}$ Output Voltage		MAX705, MAX706, MAX813L, $I_{SOURCE} = 800\mu A$	$V_{CC} - 1.5$			V
		MAX705, MAX706, MAX813L, $I_{SINK} = 1.2mA$	0.4			
$\overline{MR}$ Pull-Up Current		$\overline{MR} = 0V$	100	250	600	$\mu A$
$\overline{MR}$ Pulse Width	$t_{MR}$		150			ns
$\overline{MR}$ Input Threshold	Low		0.8			V
	High		2.0			
$\overline{MR}$ to Reset Out Delay (Note 2)	$t_{MD}$				250	ns
PFI Input Threshold		$V_{CC} = 5V$	1.20	1.25	1.30	V
PFI Input Current			-25.00	+0.01	+25.00	nA
$\overline{PFO}$ Output Voltage		$I_{SOURCE} = 800\mu A$	$V_{CC} - 1.5$			V
		$I_{SINK} = 3.2mA$	0.4			

**Note 2:** Applies to both  $\overline{RESET}$  in the MAX705–MAX708 and RESET in the MAX707/MAX708/MAX813L.

MAX705–MAX708/MAX813L

MAX705–MAX708/MAX813L  
 Low-Cost,  $\mu$ P Supervisory Circuits

Typical Operating Characteristics

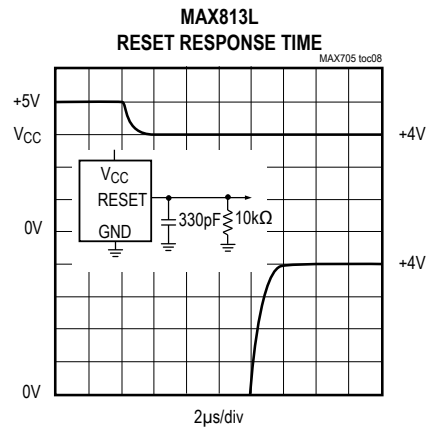
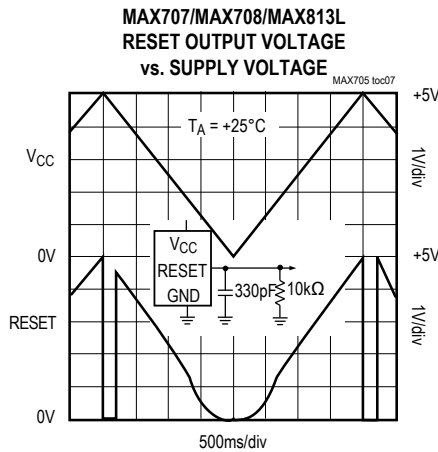
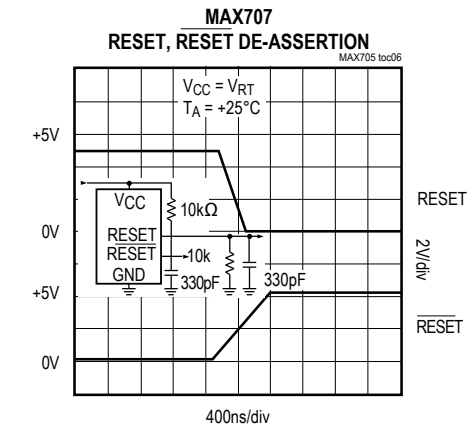
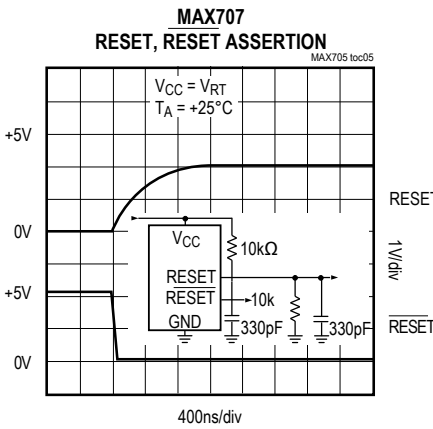
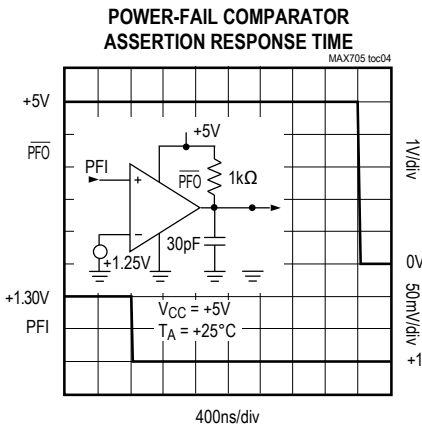
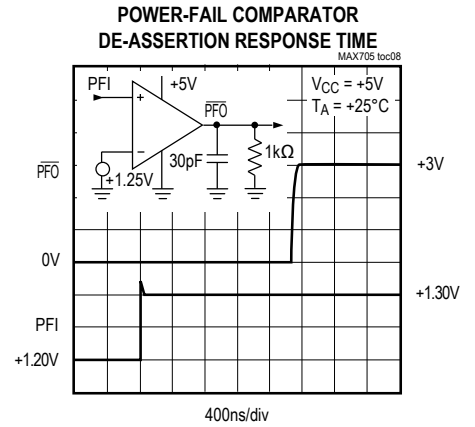
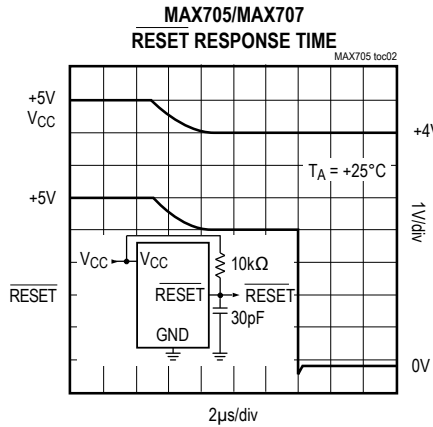
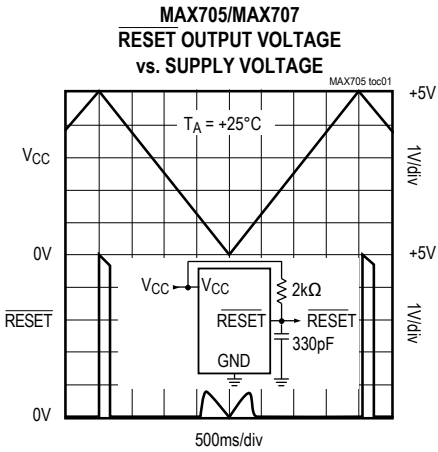

## MAX705–MAX708/MAX813L

## MAX705–MAX708/MAX813L Low-Cost, $\mu$ P Supervisory Circuits

### Pin Description

PIN						NAME	FUNCTION
MAX705/MAX706		MAX707/MAX708		MAX813L			
DIP/SO	$\mu$ MAX	DIP/SO	$\mu$ MAX	DIP/SO	$\mu$ MAX		
1	3	1	3	1	3	$\overline{\text{MR}}$	Manual-Reset Input triggers a reset pulse when pulled below 0.8V. This active-low input has an internal 250 $\mu$ A pullup current. It can be driven from a TTL or CMOS logic line, as well as shorted to ground with a switch.
2	4	2	4	2	4	$V_{\text{CC}}$	+5V Supply Input
3	5	3	5	3	5	GND	0V Ground Reference for all signals
4	6	4	6	4	6	PFI	Power-Fail Voltage-Monitor Input. When PFI is less than 1.25V, $\overline{\text{PFO}}$ goes low. Connect PFI to GND or $V_{\text{CC}}$ when not used.
5	7	5	7	5	7	$\overline{\text{PFO}}$	Power-Fail Output goes low and sinks current when PFI is less than 1.25V; otherwise $\overline{\text{PFO}}$ stays high.
6	8	—	—	6	8	$\overline{\text{WDI}}$	Watchdog Input. If $\overline{\text{WDI}}$ remains high or low for 1.6sec, the internal watchdog timer runs out and $\overline{\text{WDO}}$ goes low (Figure 1). Floating $\overline{\text{WDI}}$ or connecting $\overline{\text{WDI}}$ to a high-impedance three-state buffer disables the watchdog feature. The internal watchdog timer clears whenever reset is asserted, $\overline{\text{WDI}}$ is three stated, or $\overline{\text{WDI}}$ sees a rising or falling edge.
—	—	6	—	—	—	N.C.	No Connect
7	1	7	1	—	—	$\overline{\text{RESET}}$	Active-Low Reset Output pulses low for 200ms when triggered, and stays low whenever $V_{\text{CC}}$ is below the reset threshold (4.65V in the MAX705 and 4.40V in the MAX706). It remains low for 200ms after $V_{\text{CC}}$ rises above the reset threshold or $\overline{\text{MR}}$ goes from low to high (Figure 3). A watchdog timeout will not trigger $\overline{\text{RESET}}$ unless $\overline{\text{WDO}}$ is connected to $\overline{\text{MR}}$ .
8	2	—	—	8	2	$\overline{\text{WDO}}$	Watchdog Output pulls low when the internal watchdog timer finishes its 1.6sec count and does not go high again until the watchdog is cleared. $\overline{\text{WDO}}$ also goes low during low-line conditions. Whenever $V_{\text{CC}}$ is below the reset threshold, $\overline{\text{WDO}}$ stays low; however, unlike $\overline{\text{RESET}}$ , $\overline{\text{WDO}}$ does not have a minimum pulse width. As soon as $V_{\text{CC}}$ rises above the reset threshold, $\overline{\text{WDO}}$ goes high with no delay.
—	—	8	2	7	1	RESET	Active-High RESET Output is the inverse of $\overline{\text{RESET}}$ . Whenever $\overline{\text{RESET}}$ is high, RESET is low, and vice versa (Figure 2). The MAX813L has a RESET output only.

## MAX705–MAX708/MAX813L

## MAX705–MAX708/MAX813L Low-Cost, $\mu$ P Supervisory Circuits

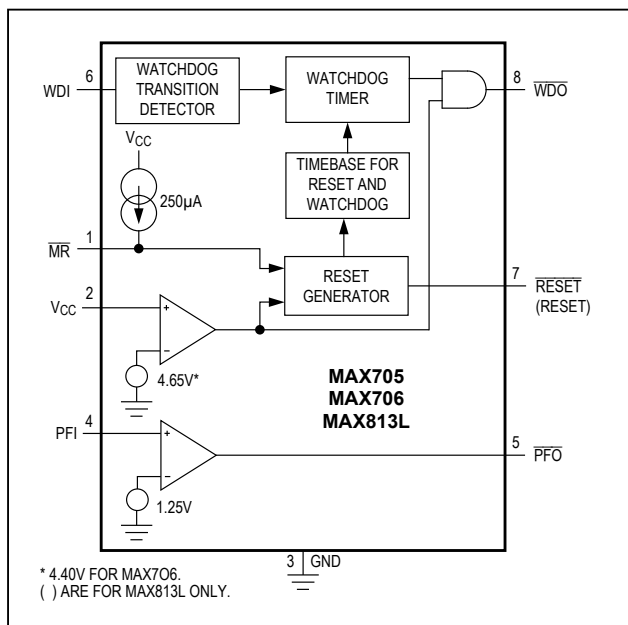

Figure 1. MAX705/MAX706/MAX813L Block Diagram

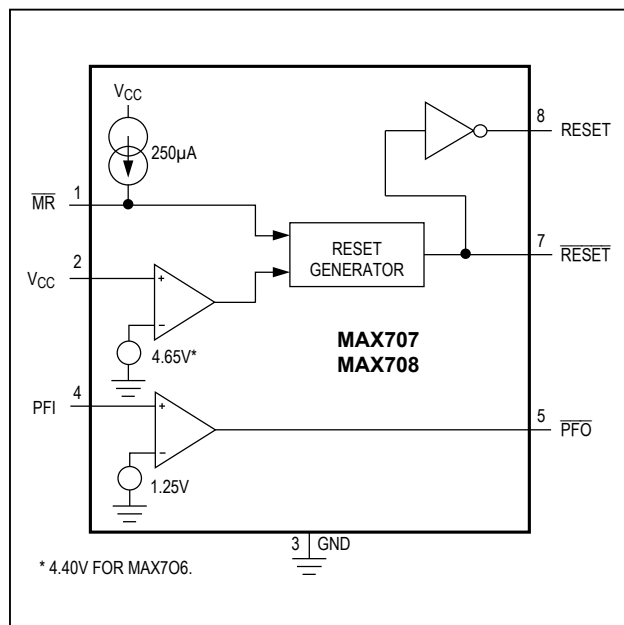

Figure 2. MAX707/MAX708 Block Diagram

## Detailed Description

### Reset Output

A microprocessor's ( $\mu$ P's) reset input starts the  $\mu$ P in a known state. Whenever the  $\mu$ P is in an unknown state, it should be held in reset. The MAX705–MAX708/MAX813L assert reset during power-up and prevent code execution errors during power-down or brownout conditions.

On power-up, once  $V_{CC}$  reaches 1V,  $\overline{RESET}$  is a guaranteed logic low of 0.4V or less. As  $V_{CC}$  rises,  $\overline{RESET}$  stays low. When  $V_{CC}$  rises above the reset threshold, an internal timer releases  $\overline{RESET}$  after about 200ms.  $\overline{RESET}$  pulses low whenever  $V_{CC}$  dips below the reset threshold, i.e. brownout condition. If brownout occurs in the middle of a previously initiated reset pulse, the pulse continues for at least another 140ms. On power-down, once  $V_{CC}$  falls below the reset threshold,  $\overline{RESET}$  stays low and is guaranteed to be 0.4V or less until  $V_{CC}$  drops below 1V.

The MAX707/MAX708/MAX813L active-high  $\overline{RESET}$  output is simply the complement of the  $\overline{RESET}$  output, and is guaranteed to be valid with  $V_{CC}$  down to 1.1V. Some  $\mu$ Ps, such as Intel's 80C51, require an active-high reset pulse.

### Watchdog Timer

The MAX705/MAX706/MAX813L watchdog circuit monitors the  $\mu$ P's activity. If the  $\mu$ P does not toggle the watchdog input (WDI) within 1.6sec and WDI is not three

stated,  $\overline{WDO}$  goes low. As long as  $\overline{RESET}$  is asserted or the WDI input is three stated, the watchdog timer stays cleared and will not count. As soon as reset is released and WDI is driven high or low, the timer starts counting. Pulses as short as 50ns can be detected.

Typically,  $\overline{WDO}$  is not connected to the nonmaskable interrupt input (NMI) of a  $\mu$ P. When  $V_{CC}$  drops below the reset threshold,  $\overline{WDO}$  goes low whether or not the watchdog timer has timed out yet. Normally this would trigger an NMI interrupt, but  $\overline{RESET}$  goes low simultaneously, and thus overrides the NMI interrupt.

If WDI is left unconnected,  $\overline{WDO}$  can be used as a low-line output. Since floating WDI disables the internal timer,  $\overline{WDO}$  goes low only when  $V_{CC}$  falls below the reset threshold, thus functioning as a low-line output.

The MAX705/MAX706 have a watchdog timer and a  $\overline{RESET}$  output. The MAX707/MAX708 have both active-high and active-low reset outputs. The MAX813L has both an active-high reset output and a watchdog timer.

### Manual Reset

The manual-reset input ( $\overline{MR}$ ) allows reset to be triggered by a pushbutton switch. The switch is effectively debounced by the 140ms minimum reset pulse width.  $\overline{MR}$  is TTL/CMOS-logic compatible, so it can be driven by an external logic line.  $\overline{MR}$  can be used to force a watchdog timeout to generate a reset pulse in the MAX705/ MAX706/ MAX813L. Simply connect  $\overline{WDO}$  to  $\overline{MR}$ .

## MAX705–MAX708/MAX813L

## MAX705–MAX708/MAX813L Low-Cost, $\mu$ P Supervisory Circuits

### Power-Fail Comparator

The power-fail comparator can be used for various purposes because its output and noninverting input are not internally connected. The inverting input is internally connected to a 1.25V reference.

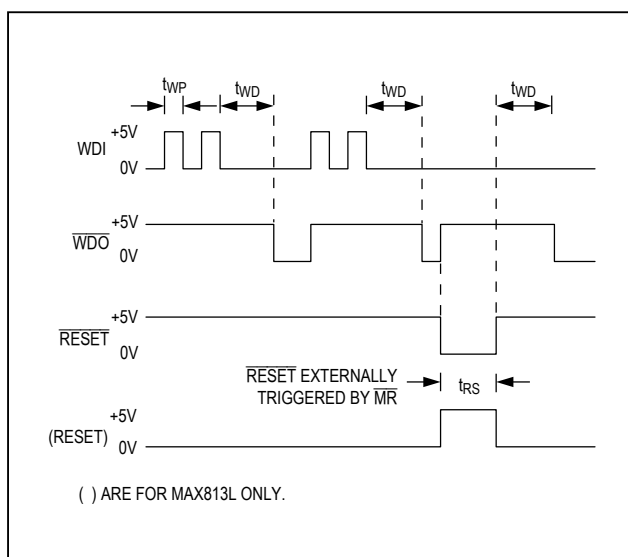

Figure 3. MAX705/MAX706/MAX813L Watchdog Timing

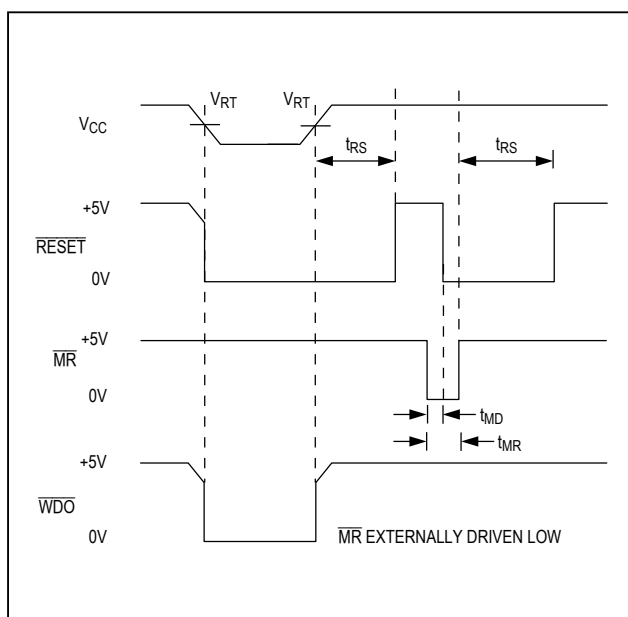

Figure 4. MAX705/MAX706  $\overline{\text{RESET}}$ , MR, and  $\overline{\text{WDO}}$  Timing with WDI Three Stated. The MAX707/MAX708/MAX813L  $\overline{\text{RESET}}$  output is the inverse of  $\overline{\text{RESET}}$  shown.

To build an early-warning circuit for power failure, connect the PFI pin to a voltage divider (see *Typical Operating Circuit*). Choose the voltage divider ratio so that the voltage at PFI falls below 1.25V just before the +5V regulator drops out. Use PFO to interrupt the  $\mu$ P so it can prepare for an orderly power-down.

### Applications Information

#### Ensuring a Valid $\overline{\text{RESET}}$ Output Down to $V_{CC} = 0V$

When  $V_{CC}$  falls below 1V, the MAX705–MAX708  $\overline{\text{RESET}}$  output no longer sinks current—it becomes an open circuit. High-impedance CMOS logic inputs can drift to undetermined voltages if left undriven. If a pulldown resistor is added to the  $\overline{\text{RESET}}$  pin, as shown in Figure 5, any stray charge or leakage currents will be drained to ground, holding  $\overline{\text{RESET}}$  low. Resistor value ( $R_1$ ) is not critical. It should be about 100k $\Omega$ , large enough not to load  $\overline{\text{RESET}}$  and small enough to pull  $\overline{\text{RESET}}$  to ground.

#### Monitoring Voltages Other Than the Unregulated DC Input

Monitor voltages other than the unregulated DC by connecting a voltage-divider to PFI and adjusting the ratio appropriately. If required, add hysteresis by connecting a resistor (with a value approximately 10 times the sum of the two resistors in the potential divider network) between PFI and PFO. A capacitor between PFI and GND reduces the power-fail circuit's sensitivity to high-frequency noise on the line being monitored.  $\overline{\text{RESET}}$  can be asserted on other voltages in addition to the +5V  $V_{CC}$  line. Connect PFO to MR to initiate a  $\overline{\text{RESET}}$  pulse when PFI drops below 1.25V. Figure 6 shows the MAX705–MAX708 configured to assert  $\overline{\text{RESET}}$  when the +5V supply falls below the reset threshold, or when the +12V supply falls below approximately 11V.

#### Monitoring a Negative Voltage

The power-fail comparator can also monitor a negative supply rail (Figure 7). When the negative rail is good (a negative voltage of large magnitude),  $\overline{\text{PFO}}$  is low, and when the negative rail is degraded (a negative voltage of lesser magnitude),  $\overline{\text{PFO}}$  is high. By adding the resistors and transistor as shown, a high  $\overline{\text{PFO}}$  triggers a reset. As long as  $\overline{\text{PFO}}$  remains high, the MAX705–MAX708/MAX813L keep reset asserted ( $\overline{\text{RESET}} = \text{low}$ ,  $\text{RESET} = \text{high}$ ). Note that this circuit's accuracy depends on the PFI threshold tolerance, the  $V_{CC}$  line, and the resistors.



MAX705–MAX708/MAX813L

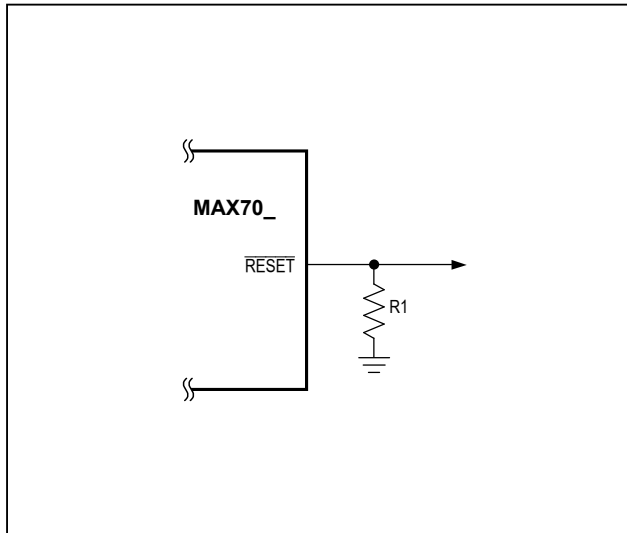

Figure 5. RESET Valid to Ground Circuit

MAX705–MAX708/MAX813L  
Low-Cost,  $\mu$ P Supervisory Circuits

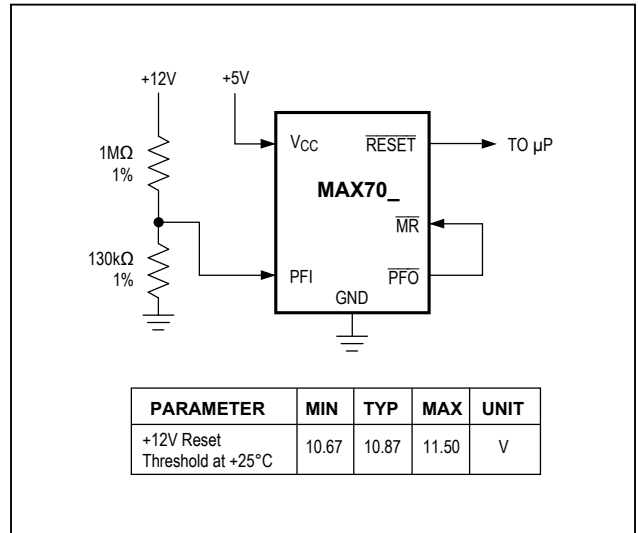

Figure 6. Monitoring Both +5V and +12V

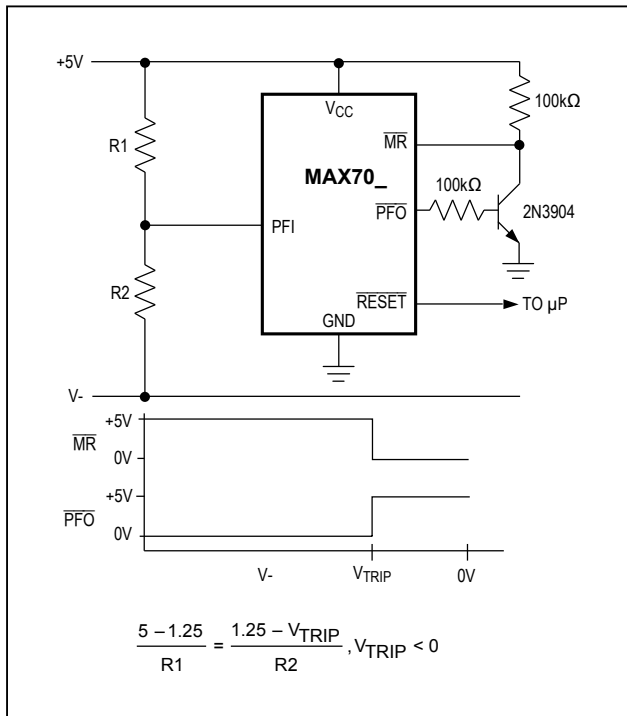

Figure 7. Monitoring a Negative Voltage

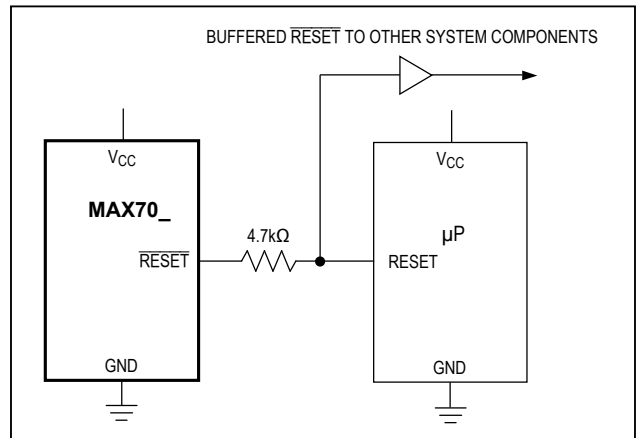

Figure 8. Buffered RESET TO OTHER SYSTEM COMPONENTS

**Interfacing to  $\mu$ Ps with Bidirectional Reset Pins**

$\mu$ Ps with bidirectional reset pins, such as the Motorola 68HC11 series, can contend with the MAX705–MAX708  $\overline{\text{RESET}}$  output. If, for example, the  $\overline{\text{RESET}}$  output is driven high and the  $\mu$ P wants to pull it low, indeterminate logic levels may result. To correct this, connect a 4.7k $\Omega$  resistor between the  $\overline{\text{RESET}}$  output and the  $\mu$ P reset I/O, as in Figure 8. Buffer the  $\overline{\text{RESET}}$  output to other system components.

## MAX705–MAX708/MAX813L

## MAX705–MAX708/MAX813L Low-Cost, $\mu$ P Supervisory Circuits

### Ordering Information (continued)

PART	TEMP RANGE	PIN-PACKAGE
MAX705EPA	-40°C to +85°C	8 Plastic DIP
MAX705ESA	-40°C to +85°C	8 SO
MAX705EUA	-40°C to +85°C	8 $\mu$ MAX
MAX705MJA	-55°C to +125°C	8 CERDIP**
<b>MAX706CPA</b>	0°C to +70°C	8 Plastic DIP
MAX706CSA	0°C to +70°C	8 SO
MAX706CUA	0°C to +70°C	8 $\mu$ MAX
MAX706C/D	0°C to +70°C	Dice*
MAX706EPA	-40°C to +85°C	8 Plastic DIP
MAX706ESA	-40°C to +85°C	8 SO
MAX706EUA	-40°C to +85°C	8 $\mu$ MAX
MAX706MJA	-55°C to +125°C	8 CERDIP**
<b>MAX707CPA</b>	0°C to +70°C	8 Plastic DIP
MAX707CSA	0°C to +70°C	8 SO
MAX707CUA	0°C to +70°C	8 $\mu$ MAX
MAX707C/D	0°C to +70°C	Dice*
MAX707EPA	-40°C to +85°C	8 Plastic DIP
MAX707ESA	-40°C to +85°C	8 SO
MAX707EUA	-40°C to +85°C	8 $\mu$ MAX
MAX707MJA	-55°C to +125°C	8 CERDIP**
<b>MAX708CPA</b>	0°C to +70°C	8 Plastic DIP
MAX708CSA	0°C to +70°C	8 SO
MAX708CUA	0°C to +70°C	8 $\mu$ MAX
MAX708C/D	0°C to +70°C	Dice*
MAX708EPA	-40°C to +85°C	8 Plastic DIP
MAX708ESA	-40°C to +85°C	8 SO
MAX708EUA	-40°C to +85°C	8 $\mu$ MAX
MAX708MJA	-55°C to +125°C	8 CERDIP**
<b>MAX813LCPA</b>	0°C to +70°C	8 Plastic DIP
MAX813LCSA	0°C to +70°C	8 SO
MAX813LCUA	0°C to +70°C	8 $\mu$ MAX
MAX813LC/D	0°C to +70°C	Dice*
MAX813LEPA	-40°C to +85°C	8 Plastic DIP
MAX813LESA	-40°C to +85°C	8 SO
MAX813LEUA	-40°C to +85°C	8 $\mu$ MAX
MAX813LMJA	-55°C to +125°C	8 CERDIP**

\*Dice are specified at  $T_A = +25^\circ\text{C}$ .

\*\*Contact factory for availability and processing to MIL-STD-883. Devices in PDIP, SO and  $\mu$ MAX packages are available in both leaded and lead-free packaging. Specify lead free by adding the + symbol at the end of the part number when ordering. Lead-free not available for CERDIP package.

### Pin Configurations

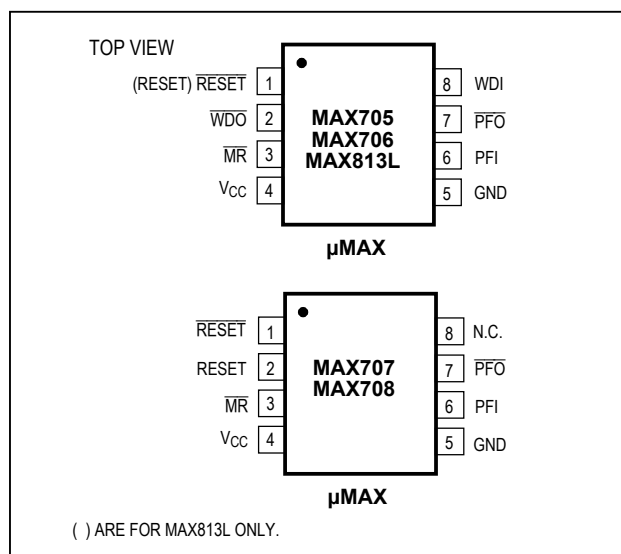
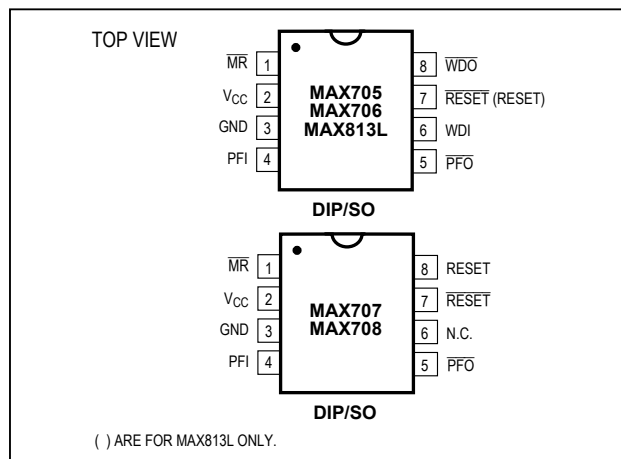

MAX705–MAX708/MAX813L

MAX705–MAX708/MAX813L  
 Low-Cost,  $\mu$ P Supervisory Circuits

Ordering Information

Part Number	Nominal Reset Threshold (V)	Minimum Reset Pulse Width (ms)	Active-Low Reset	Active-High Reset	$\overline{\text{RESET}}$ Valid to $V_{\text{CC}} = 1\text{V}$	Nominal Watchdog Timeout Period (sec), if Available	Separate Watchdog Output	Backup-Battery Switch	$V_{\text{CC-to-V}_{\text{OUT}}}$ On Resistance Max ( $\Omega$ )	$V_{\text{BATT-to-V}_{\text{OUT}}}$ On Resistance Max ( $\Omega$ )	$\overline{\text{CE}}$ Write Protect	Power-Fail Comparator	Manual-Reset Input	Low-Line Output	Battery-On Output	Supply Operating Mode mA (typ)	Supply Backup Mode $\mu\text{A}$ max (typ)	Pins	Price† 1000-up (\$)
MAX1232	4.37/4.62	250	✓	✓	✓	0.15/0.6/1.2			10	400		✓	✓			0.2(0.05)	5(0.05)	8	1.71
MAX690A/692A	4.65/4.40	140	✓	✓	✓	1.6	✓	✓	6	400		✓				0.35(0.2)	10(4)	8	3.26
MAX690R/S/T	2.63/2.93/3.08	140	✓	✓	✓	1.6	✓	✓	6	400		✓				0.5(0.4)	5(0.04)	8	3.23
MAX691A/693A	4.65/4.40	140/adj.	✓	✓	✓	1.6/adj.	✓	✓	1.2	25	✓/10ns	✓			✓	0.1(0.035)	5(0.04)	16	3.61
MAX11691	The MAX11691 is a module with the MAX691A and a 125mAh lithium battery																		
MAX696	Adj.	35/adj.	✓	✓	✓	1.6/adj.	✓	✓				✓						16	3.55
MAX697	Adj.	35/adj.	✓	✓	✓	1.6/adj.	✓	✓				✓						16	3.58
MAX700	4.65/adj.	200	✓	✓	✓								✓			0.2(0.1)		8	2.17
MAX703/704	4.65/4.40	140	✓	✓	✓			✓	10	400		✓				0.35(0.2)	5(0.05)	8	1.38*
MAX704R/S/T	2.63/2.93/3.08	140	✓	✓	✓	1.6	✓	✓	6	400		✓				0.5(0.4)	10(4)	8	2.93
MAX705/706	4.65/4.40	140	✓	✓	✓	1.6	✓	✓				✓				0.35(0.2)		8	1.02*
MAX706P	2.63	140	✓	✓	✓	1.6	✓	✓				✓				0.35(0.2)		8	1.71
MAX706R/S/T	2.63/2.93/3.08	140	✓	✓	✓	1.6	✓	✓				✓				0.35(0.2)		8	1.71
MAX707/708	4.65/4.40	140	✓	✓	✓			✓				✓				0.35(0.2)		8	0.88*
MAX708R/S/T	2.63/2.93/3.08	140	✓	✓	✓			✓				✓				0.35(0.2)		8	1.63
MAX791	4.65	140	✓	✓	✓	1	✓	✓	1.2	25	✓/10ns	✓		✓	✓	0.15(0.06)	5(0.04)	16	3.90
MAX802L/IR/S/T	4.60/4.40/ 2.63/2.93/3.08	140	✓	✓	✓	1	✓	✓			✓/10ns	✓				0.15(0.07)		16	3.42
MAX793R/S/UIT	2.63/2.93/3.07/3.08	140	✓	✓	✓	1.6	✓	✓	TBD	TBD	✓	✓			TBD	TBD	TBD	16	††
MAX794	Adj.	140	✓	✓	✓	1.6	✓	✓	TBD	TBD	✓	✓			TBD	TBD	TBD	8	††
MAX795R/S/UIT	2.63/2.93/3.07/3.08	140	✓	✓	✓	1.6/adj.	✓	✓	TBD	TBD	✓	✓			TBD	TBD	TBD	16	††
MAX800L/IM	4.60/4.40	140	✓	✓	✓	1.6/adj.	✓	✓	1.2	25	✓/10ns	✓/±2%			✓	0.1(0.035)	5(0.04)	8	3.88
MAX801L/IN/IM	4.68/4.58/4.43	140	✓/±1.5%	✓	✓	1.6	✓	✓	TBD	TBD		✓			TBD	TBD	TBD	8	††
MAX802L/IR/S/T	4.60/4.40/ 2.63/2.93/3.08	140	✓	✓	✓	1.6	✓	✓	10	400		✓/±2%				0.35(0.2)	5(0.05)	8	3.59
MAX804R/S/T	2.63/2.93/3.08	140	✓	✓	✓	1.6	✓	✓	6	400		✓/±2%				0.5(0.4)	10(4)	8	3.66
MAX805L/IR/S/T	4.65/4.40/ 2.63/2.93/3.08	140	✓	✓	✓	1.6	✓	✓	10	400		✓				0.35(0.2)	5(0.05)	8	3.26
MAX806R/S/T	2.63/2.93/3.08	140	✓	✓	✓	1.6	✓	✓	6	400		✓/±2%				0.5(0.4)	10(4)	8	3.90
MAX807L/IN/IM	4.68/4.58/4.43	140	✓/±1.5%	✓	✓	1.6	✓	✓	TBD	TBD	✓	✓		✓	TBD	TBD	TBD	8	††
MAX808L/IN/IM	4.68/4.58/4.43	140	✓/±1.5%	✓	✓		✓	✓	TBD	TBD	✓	✓		✓	TBD	TBD	TBD	16	††
MAX809L/IR/S/T	4.65/4.40/ 2.63/2.93/3.08	140	✓	✓	✓		✓	✓								0.06 (0.024)		3	††
MAX810L/IR/S/T	4.65/4.40/ 2.63/2.93/3.08	140	✓	✓	✓		✓	✓								0.06 (0.024)		3	††
MAX813L	4.65	140	✓	✓	✓	1.6	✓	✓				✓/±2%				0.35(0.2)		8	1.02*
MAX814K/L/INT	4.80/4.70/4.55/3.03	140	✓/±1%	✓/±1%	✓		✓	✓				✓/±2%		✓		TBD	TBD	8	††
MAX815K/L/INT	4.80/4.70/4.55/3.03	140	✓/±1%	✓/±1%	✓	1.6	✓	✓				✓/±2%				TBD	TBD	8	††
MAX816	Adj./±1%	140	✓	✓	✓		✓	✓				✓/±2%				TBD	TBD	8	††
MAX820L/IR/S/T	4.65/4.40/ 2.63/2.93/3.08	140	✓	✓	✓	1	✓	✓			✓/10ns	✓/±2%		✓		0.15 (0.07)		16	3.82
MXD1210	4.37/4.62						✓	✓	2.5	667	✓	✓				0.5(0.23)	0.1(0.002)	8	2.44

**MAX705–MAX708/MAX813L**

**MAX705–MAX708/MAX813L**  
 Low-Cost,  $\mu$ P Supervisory Circuits

**Package Information**

For the latest package outline information and land patterns (footprints), go to [www.maximintegrated.com/packages](http://www.maximintegrated.com/packages). Note that a "+", "#", or "-" in the package code indicates RoHS status only. Package drawings may show a different suffix character, but the drawing pertains to the package regardless of RoHS status.

PACKAGE TYPE	PACKAGE CODE	OUTLINE NO.
8 $\mu$ MAX	U8+1	<a href="#">21-0036</a>
8 Plastic DIP	P8+1	<a href="#">21-0043</a>
8 SO	S8+2	<a href="#">21-0041</a>

**Chip Topography**

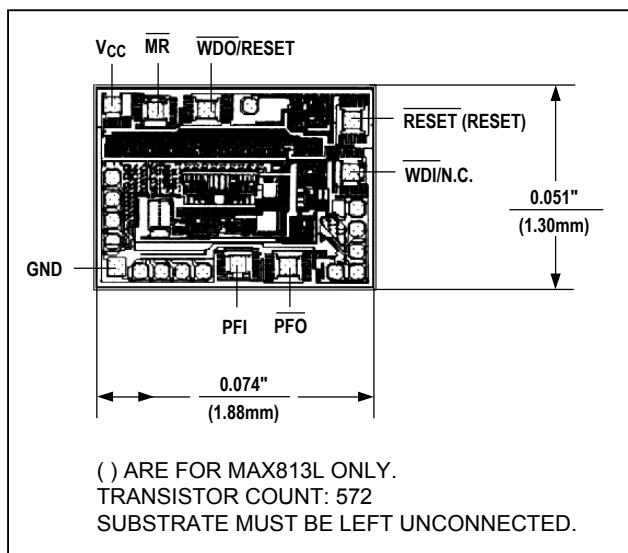

## MAX705–MAX708/MAX813L

## Low-Cost, $\mu$ P Supervisory Circuits

### Revision History

REVISION NUMBER	REVISION DATE	DESCRIPTION	PAGES CHANGED
0	2/92	Initial release	—
8	3/10	Updated the <i>Features</i> , <i>Absolute Maximum Ratings</i> , <i>Typical Operating Characteristics</i> , Figures 3, 7, 8, and the <i>Package Information</i> sections	1, 2, 4, 7, 8, 10
9	1/13	Updated package code for 8 SO package	11
10	4/15	Deleted “Automotive Systems” from <i>Applications</i> and updated <i>Benefits and Features</i> sections	1

For pricing, delivery, and ordering information, please contact Maxim Direct at 1-888-629-4642, or visit Maxim Integrated's website at [www.maximintegrated.com](http://www.maximintegrated.com).

*Maxim Integrated cannot assume responsibility for use of any circuitry other than circuitry entirely embodied in a Maxim Integrated product. No circuit patent licenses are implied. Maxim Integrated reserves the right to change the circuitry and specifications without notice at any time. The parametric values (min and max limits) shown in the Electrical Characteristics table are guaranteed. Other parametric values quoted in this data sheet are provided for guidance.*