

## Excellent Integrated System Limited

Stocking Distributor

Click to view price, real time Inventory, Delivery & Lifecycle Information:

[E-Switch](#)  
[TL6700NF260QG](#)

For any questions, you can email us directly:

[sales@integrated-circuit.com](mailto:sales@integrated-circuit.com)

SHEET 1 OF 1

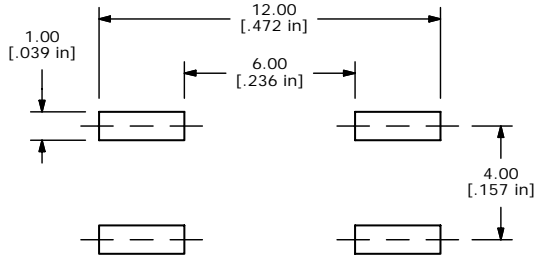

P.C.B. MOUNTING LAYOUT

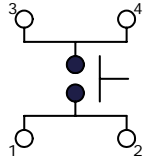

CIRCUIT: SPST

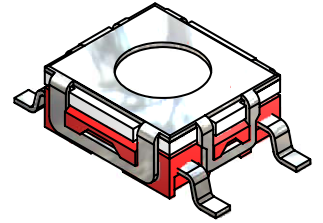
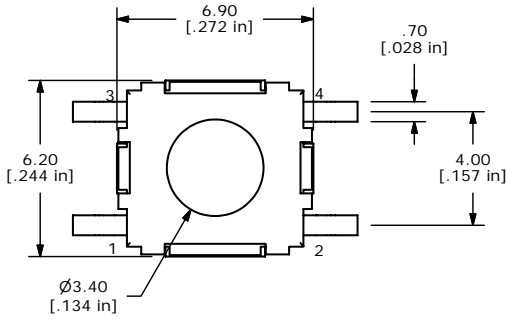

ISOMETRIC

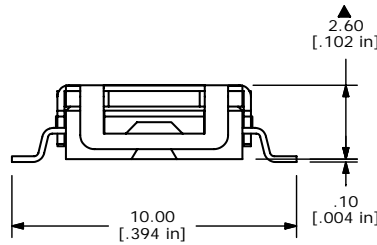

NOTES:

1. GENERAL TOLERANCE:  $x.x \pm 0.4$   
 $x.xx \pm 0.25$
2. RATING: 50mA@12VDC
3. TRAVEL:  $0.35 \pm 0.2$ mm
4. CONTACT RESISTANCE: 100m OHMS
5. LIFE CYCLES: 100,000 CYCLES
- ▲6. OPERATING FORCE:  $260 \pm 50$ gf
7. ▲DENOTES CRITICAL PARAMETER
8. PACKAGE: TAPE AND REEL, 1400 PIECES PER REEL
9. 2002/95/EC (ROHS) COMPLIANT
- ▲10. CONTACT MATERIAL: SILVER



TITLE TL6700NF260QG

A	16653	RELEASED FOR PRODUCTION	11/14/2006	TN
REV	PCR NO	DESCRIPTION	DATE	BY

THE INFORMATION CONTAINED IN THIS DOCUMENT IS PROPRIETARY TO E-SWITCH AND IS NOT TO BE COPIED OR TRANSFERRED

SCALE 5:1	DATE 11/14/2006	DR TN	DWG P010459	REV A
-----------	-----------------	-------	-------------	-------