

Excellent Integrated System Limited

Stocking Distributor

Click to view price, real time Inventory, Delivery & Lifecycle Information:

[Maxim Integrated](#)
[MAX6603ATB+T](#)

For any questions, you can email us directly:

sales@integrated-circuit.com

MAX6603

Dual-Channel, Platinum RTD-to-Voltage Signal Conditioner

General Description

The MAX6603 dual-channel, platinum RTD-to-voltage signal conditioner excites and amplifies the signal from two external 200Ω platinum-resistive temperature devices (Pt RTD) to achieve high-voltage, level-filtered signals for temperature measurements. The MAX6603 provides a direct ratiometric output voltage to simplify the interface to microcontrollers with integrated analog-to-digital converters (ADCs). External precision resistors and calibration processes are not needed. The MAX6603 provides the necessary signal-conditioning functions, including ratiometric excitation current, amplification, buffered voltage outputs, diagnostic fault detections, and input protection. The MAX6603 amplifies signals from two RTDs operating over the -40°C to +1000°C temperature range and provides the temperature information as two independent analog voltages. The MAX6603 features a ±6°C (max) accuracy over the +400°C to +600°C temperature range.

The MAX6603 has overvoltage protection up to +16V on RTD inputs, and ±5kV electrostatic discharge (ESD) protection at RTD input pins for reliable operation where RTD temperature-sensing probes are used. The MAX6603 monitors the RTD for faults and asserts the respective DG output low for fault conditions. The analog voltage outputs can be readily connected to a variety of microcontrollers.

The MAX6603 is available in a small, 10-pin TDFN-EP package and operates over the -40°C to +125°C automotive temperature range from a single +3V to +5.5V power supply.

Applications

- Engine Control Management to Meet EURO IV Regulations
- Braking Systems
- Industrial Temperature Sensors
- Food Transportation Monitoring Systems
- Industrial Process Measurements

Features

- Amplifies Pt RTD Temperature Signals
- ±5kV ESD Protection on RTD Inputs
- +16V Overvoltage Fault Protection on RTD Inputs
- Low RTD Excitation Current Minimizes Self-Heating Errors
- Small, 10-Pin TDFN Package
- Fully Ratiometric Operation
- No Calibration Required for Standard RTDs
- RTD Diagnostic Check
- High Accuracy: ±6°C (max) from +400°C to +600°C

Ordering Information

PART	PIN-PACKAGE	RTD	PKG CODE
MAX6603ATB+	10 TDFN-EP*	200Ω**	T1033-1

Note: Device is specified over the -40°C to +125°C temperature range.

*EP = Exposed pad.

+Denotes a lead(Pb)-free/RoHS-compliant package.

**Other base resistance values can be accommodated.

Contact the factory for more information.

Pin Configuration

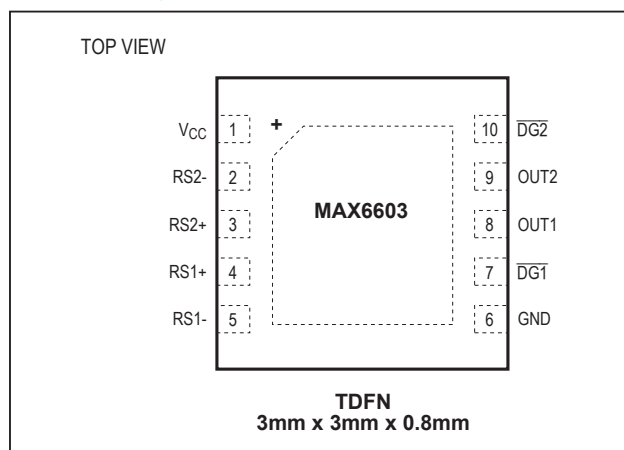

MAX6603

Dual-Channel, Platinum RTD-to-Voltage Signal Conditioner

Absolute Maximum Ratings

(All voltages referenced to GND, unless otherwise noted.)

V _{CC}	-0.3V to +6.0V
RS1+, RS1-, RS2+, RS2-.....	-0.3V to +18.0V
OUT1, OUT2, $\overline{DG1}$, $\overline{DG2}$	-0.3V to (V _{CC} + 0.3V)
Continuous Power Dissipation (T _A = +70°C)	
10-Pin TDFN Single-Layer Board	
(derate 18.5 mW/°C above +70°C)	1481.5mW
10-Pin TDFN Multilayer Board	
(derate 24.4 mW/°C above +70°C)	1951.2mW

ESD Protection (OUT1, OUT2, $\overline{DG1}$, $\overline{DG2}$, Human Body Model).....	>±2kV
ESD Protection (RS1+, RS2+, RS1-, RS2-, V _{CC} , GND, Human Body Model).....	>±5kV
Operating Temperature Range.....	-40°C to +125°C
Junction Temperature	+150°C
Storage Temperature Range	-65°C to +150°C
Lead Temperature (soldering, 10s)	+300°C

Stresses beyond those listed under "Absolute Maximum Ratings" may cause permanent damage to the device. These are stress ratings only, and functional operation of the device at these or any other conditions beyond those indicated in the operational sections of the specifications is not implied. Exposure to absolute maximum rating conditions for extended periods may affect device reliability.

Electrical Characteristics

(V_{CC} = 3.0V to 5.5V, resistor connected between RS1+ and RS1- = 560Ω, resistor connected between RS2+ and RS2- = 560Ω, T_A = -40°C to +125°C, unless otherwise noted. Typical values are at V_{CC} = 5.0V, R_L = 47kΩ between OUT₋ and GND, T_A = +25°C.) (Note 1)

PARAMETER	SYMBOL	CONDITIONS	MIN	TYP	MAX	UNITS
Supply Voltage	V _{CC}		3.0		5.5	V
Input Over Voltage	V _{RS}	RS1+, RS1-, RS2+, RS2-			16	V
Supply Current	I _{CC}			3.9	5.5	mA
		Sink current during overvoltage fault V _{RS1+} = V _{RS1-} = V _{RS2+} = V _{RS2-} = +16V		36.2	47.1	
CURRENT SOURCES						
Excitation Current	I _{EXC}	(Note 2)	0.58	1.0	1.12	mA
Excitation-Current Temperature Coefficient	TC _{IEXC}	(Note 2)		-7		ppm/°C
Minimum RS ₋ Voltage	V _{RS-}			3.4		V
Maximum RS ₊ Voltage	V _{RS+}			4.0		V
Supply Ratiometric	I _{RATIO}	V _{CC} = +3V to +5.5V		0.2		mAV
MAXIMUM TEMPERATURE ERROR (Note 3)						
RTD		+400°C to +600°C, V _{CC} = 5.0V			±6	°C
		-40°C to +400°C, V _{CC} = 5.0V			±8	
		+600°C to +1000°C, V _{CC} = 5.0V			±12	
		+400°C to +600°C, V _{CC} = 3.0V			±10	
		-40°C to +400°C, V _{CC} = 3.0V			±13.3	
		+600°C to +1000°C, V _{CC} = 3.0V			±20	

MAX6603

Dual-Channel, Platinum RTD-to-Voltage Signal Conditioner

Electrical Characteristics (continued)

($V_{CC} = 3.0V$ to $5.5V$, resistor connected between $RS1+$ and $RS1-$ = 560Ω , resistor connected between $RS2+$ and $RS2-$ = 560Ω , $T_A = -40^\circ C$ to $+125^\circ C$, unless otherwise noted. Typical values are at $V_{CC} = 5.0V$, $R_L = 47k\Omega$ between OUT_- and GND, $T_A = +25^\circ C$.) (Note 1)

PARAMETER	SYMBOL	CONDITIONS	MIN	TYP	MAX	UNITS
MAXIMUM INPUT RESISTANCE-TO-OUTPUT VOLTAGE ERROR						
RTD (Note 4)		494 Ω to 627 Ω , $V_{CC} = 5.0V$			19	mV
		200 Ω to 494 Ω , $V_{CC} = 5.0V$			27	
		627 Ω to 866 Ω , $V_{CC} = 5.0V$			33	
		494 Ω to 627 Ω , $V_{CC} = 3.0V$			19	
		200 Ω to 494 Ω , $V_{CC} = 3.0V$			27	
		627 Ω to 866 Ω , $V_{CC} = 3.0V$			33	
ANALOG OUTPUTS (OUT1, OUT2)						
Output-Voltage Low (Max)	V_{OL}	$R_L = 47k\Omega$ between OUT_- and V_{CC} (Note 5)		0.1		V
Output-Voltage High (Min)	V_{OH}	$R_L = 47k\Omega$ between OUT_- and GND (Note 5)		$V_{CC} - 0.1$		V
Short-Circuit Current	I_{SC}	$V_{OUT} = V_{CC}$			22	mA
		$V_{OUT} = GND$			12	mA
Maximum Capacitive Load	C_L			500		pF
Minimum Resistive Load	R_L	Between OUT_- and GND		20		k Ω
DIAGNOSTIC OUTPUTS ($\overline{DG1}$, $\overline{DG2}$)						
Output-Voltage Low	V_{OL}	$I_{SOURCE} = 1mA$			0.2	V
Output-Voltage High	V_{OH}	$I_{SINK} = 1mA$		$V_{CC} - 0.2$		V
Minimum Resistance for $RS+$, $RS - Open$	$R_{RS - OPEN}$			8000		Ω
Maximum Resistance for $RS+$, $RS - Short$	$R_{RS - SHORT}$			60		Ω

Note 1: All parameters are tested at $T_A = +25^\circ C$. Specifications over temperature are guaranteed by design.

Note 2: RTD resistance range is 150Ω to 900Ω for constant excitation current.

Note 3: A typical 200Ω RTD: $R(T) = R_0[1 + AT + BT^2]$ is referenced for probe temperature-probe resistance relation. The parameters in this section are not tested and are for reference only.

Note 4: RTD resistance is tested only at $R_{RTD} = 200\Omega$, 560Ω , 845Ω . The range is guaranteed by design.

Note 5: Parameters are tested in special test mode.

MAX6603

**Dual-Channel, Platinum RTD-to-Voltage
Signal Conditioner**

Typical Operating Characteristics

($V_{CC} = 5.0V$, $T_A = +25^\circ C$, unless otherwise noted.)

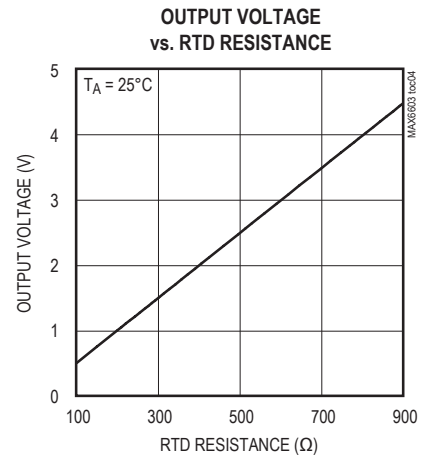
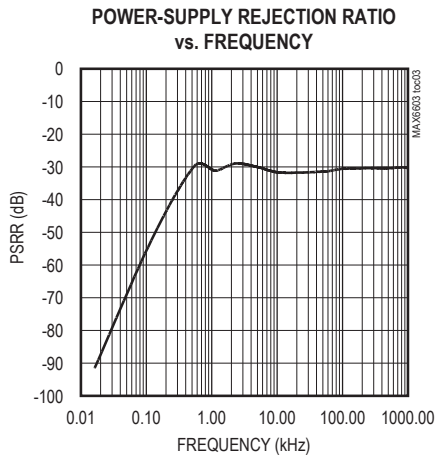
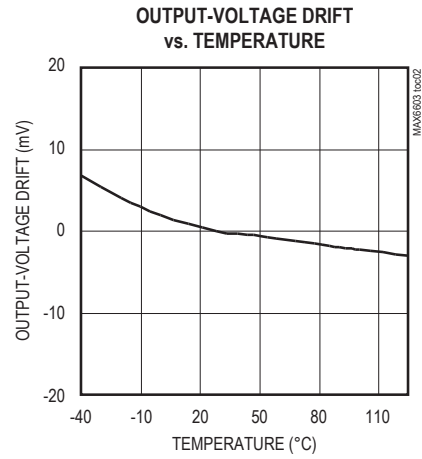
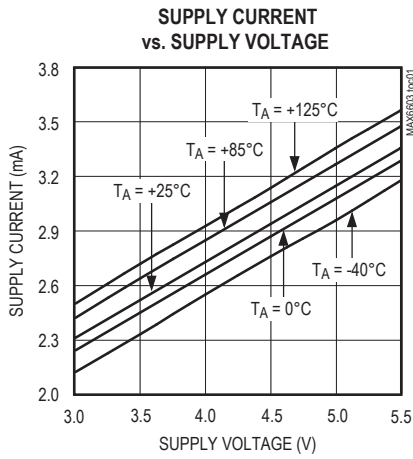

MAX6603

Dual-Channel, Platinum RTD-to-Voltage Signal Conditioner

Pin Description

PIN	NAME	FUNCTION
1	V _{CC}	Power-Supply Input. Bypass to GND with a 0.1μF capacitor as close to V _{CC} as possible.
2	RS2-	Sense Resistor 2 Negative Input
3	RS2+	Sense Resistor 2 Positive Input
4	RS1+	Sense Resistor 1 Positive Input
5	RS1-	Sense Resistor 1 Negative Input
6	GND	Ground
7	DG1	Diagnostic Output Signal 1. DG1 asserts low upon fault detection.
8	OUT1	Output Analog Voltage 1. OUT1 is high impedance upon DG1 assertion.
9	OUT2	Output Analog Voltage 2. OUT2 is high impedance upon DG2 assertion.
10	DG2	Diagnostic Output Signal 2. DG2 asserts low upon fault detection.
—	EP	Exposed Pad. Connect to GND.

Functional Block Diagram

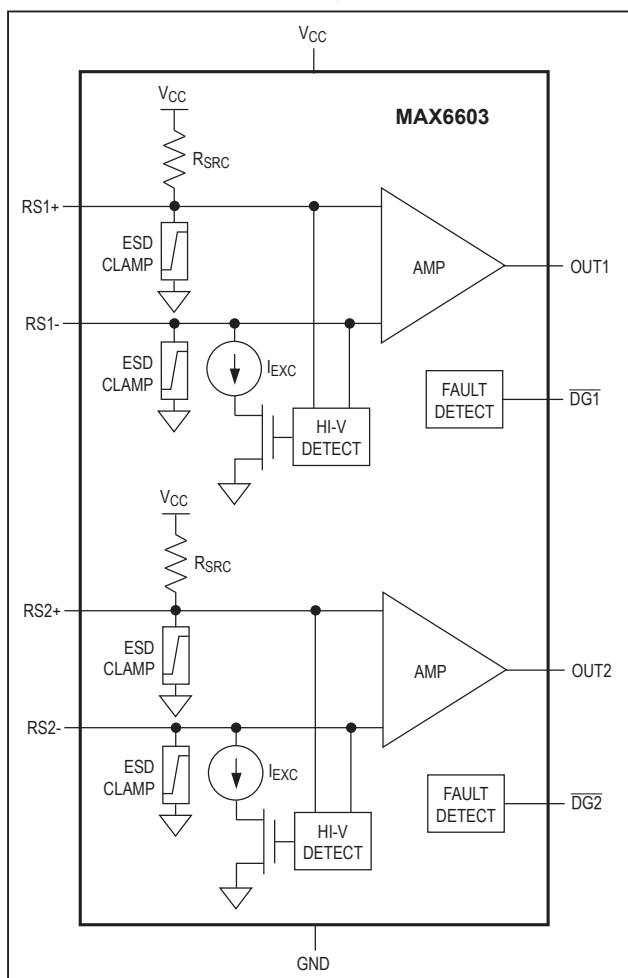

Detailed Description

The MAX6603 converts a Deutsche Institute for Normung (DIN) standard 200Ω Pt RTD to a high-level analog voltage without the need for external trims or precise discrete components. The Pt RTD resistance conveys temperature information approximated by the Callendar-Van Dusen equation and is represented in Figure 1:

$$R(T) = R_0[1 + AT + BT^2 + CT^3]$$

where: $R(T)$ = Resistance of Pt RTD at temperature (T)

R_0 = Base resistance in ohms at 0°C

T = Temperature in °C

$A = 3.9083 \text{ E-3 } ^\circ\text{C}^{-1}$ (alpha coefficient 1)

$B = -5.7750 \text{ E-7 } ^\circ\text{C}^{-2}$ (alpha coefficient 2)

$C = 0$ (approximation for temperatures > 0°C)

(Alpha coefficients can vary depending on standards.)

The MAX6603 applies a constant excitation current of 1mA (typ) through the Pt RTD, generating a voltage drop that is amplified and results in a high-level output voltage. The excitation current (I_{EXC}) typically varies ratiometrically by 0.2mA/V (typ) with respect to V_{CC}, and therefore, the amplified signal is ratiometric to the power supply. The voltage amplification from input to output is 5 (typ). The output voltage is applied to a ratiometric ADC to produce a digital value independent of supply voltage. For ADCs that use V_{CC} as their reference voltage, sudden changes in the supply voltage do not affect the microcontroller's reading of the temperature. Ratiometricity simplifies the connection to most microcontrollers that incorporate an ADC and

MAX6603

Dual-Channel, Platinum RTD-to-Voltage Signal Conditioner

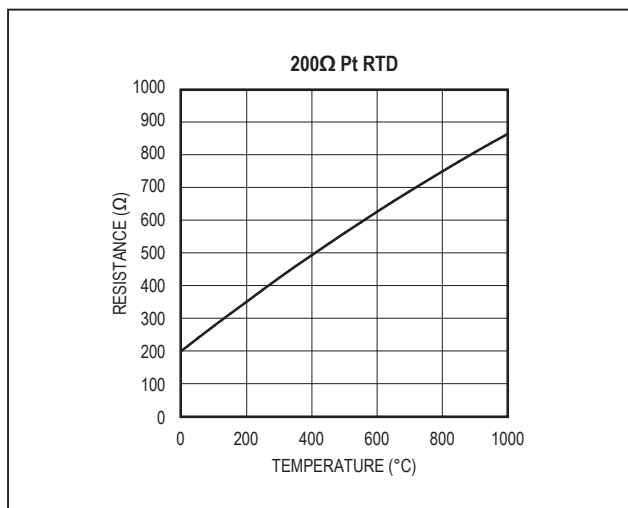

Figure 1. Typical 200Ω Pt RTD Representation by the Simplified Callender-Van Dusen Equation

enables a low-cost, low-complexity solution. Ratiometricity is an important consideration for battery-operated instruments and some industrial applications.

Temperature Information

The MAX6603 measures the resistance between the RTD and translates that into a high-level output voltage. The resistance range of the MAX6603 is between 150Ω and 900Ω, covering a -40°C to +1000°C temperature range. When R(T) goes too low or too high, a fault condition is asserted and the respective \overline{DG}_- goes low.

Output Voltage

The following equation describes the output voltage:

$$V_{OUT} = \frac{V_{CC} \times R(T)}{1000}$$

where:

- V_{CC} = supply voltage
- R(T) = RTD resistance given by Callendar-Van Dusen equation.

Using Other Pt RTDs

The MAX6603 is designed for a 200Ω Pt RTD, but the device can work with any RTD as long as the resistance is in the 150Ω to 900Ω range. A 500Ω Pt RTD can be used for temperatures up to +208°C because that temperature results in R(T) = 900Ω.

Input Overvoltage Protection to +16V

The input pins RS1+, RS1-, RS2+, and RS2- protect the MAX6603 from overvoltage conditions up to +16V without damaging the device.

Diagnostic Outputs (\overline{DG}_1 , \overline{DG}_2)

The MAX6603 continuously monitors the excitation current to the RTD, the resultant voltage drop, and voltage levels of the inputs to detect fault conditions. Any fault condition causes the respective \overline{DG} output to assert low. Fault conditions occur for RTD open circuits; RTD short circuits; and RS1+, RS1-, RS2+, and RS2- short to ground or supply. If any fault is detected, the respective \overline{DG} output asserts low. OUT1 and OUT2 are high impedance on assertion of \overline{DG}_1 and \overline{DG}_2 , respectively. An example circuit showing potential fault conditions is shown in Figure 2.

Applications Information

Ratiometric Output Coupled to a Microcontroller

The circuit of Figure 3 shows the MAX6603 connected to the microcontroller using V_{CC} as the ADC reference voltage. The output is ratiometric to V_{CC} , and temperature measurements are independent of the supply voltage.

Chip Information

PROCESS: BiCMOS

MAX6603

**Dual-Channel, Platinum RTD-to-Voltage
Signal Conditioner**

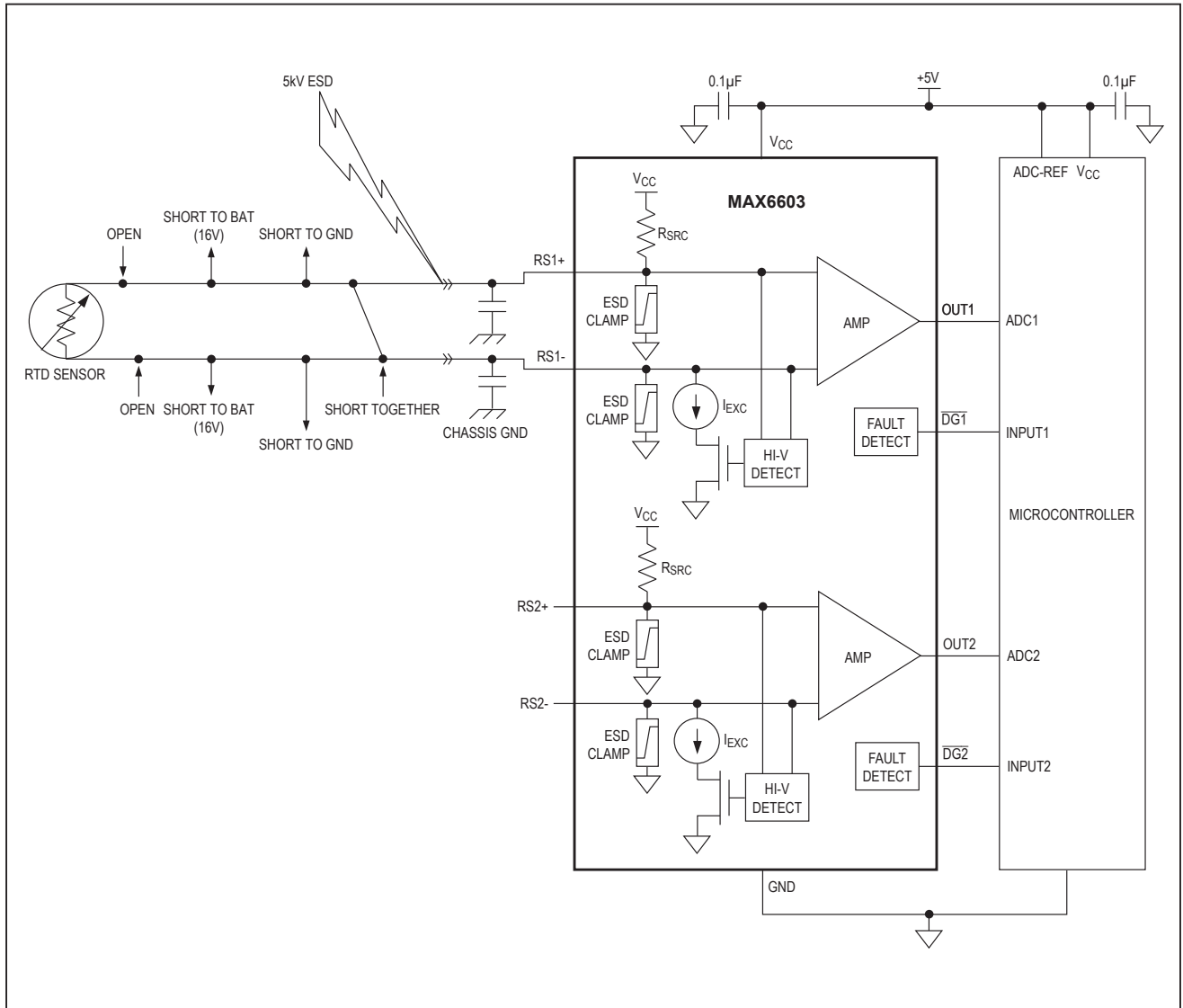

Figure 2. The various fault conditions that cause the diagnostic output to assert low are shown for a single channel.

MAX6603

Dual-Channel, Platinum RTD-to-Voltage
Signal Conditioner

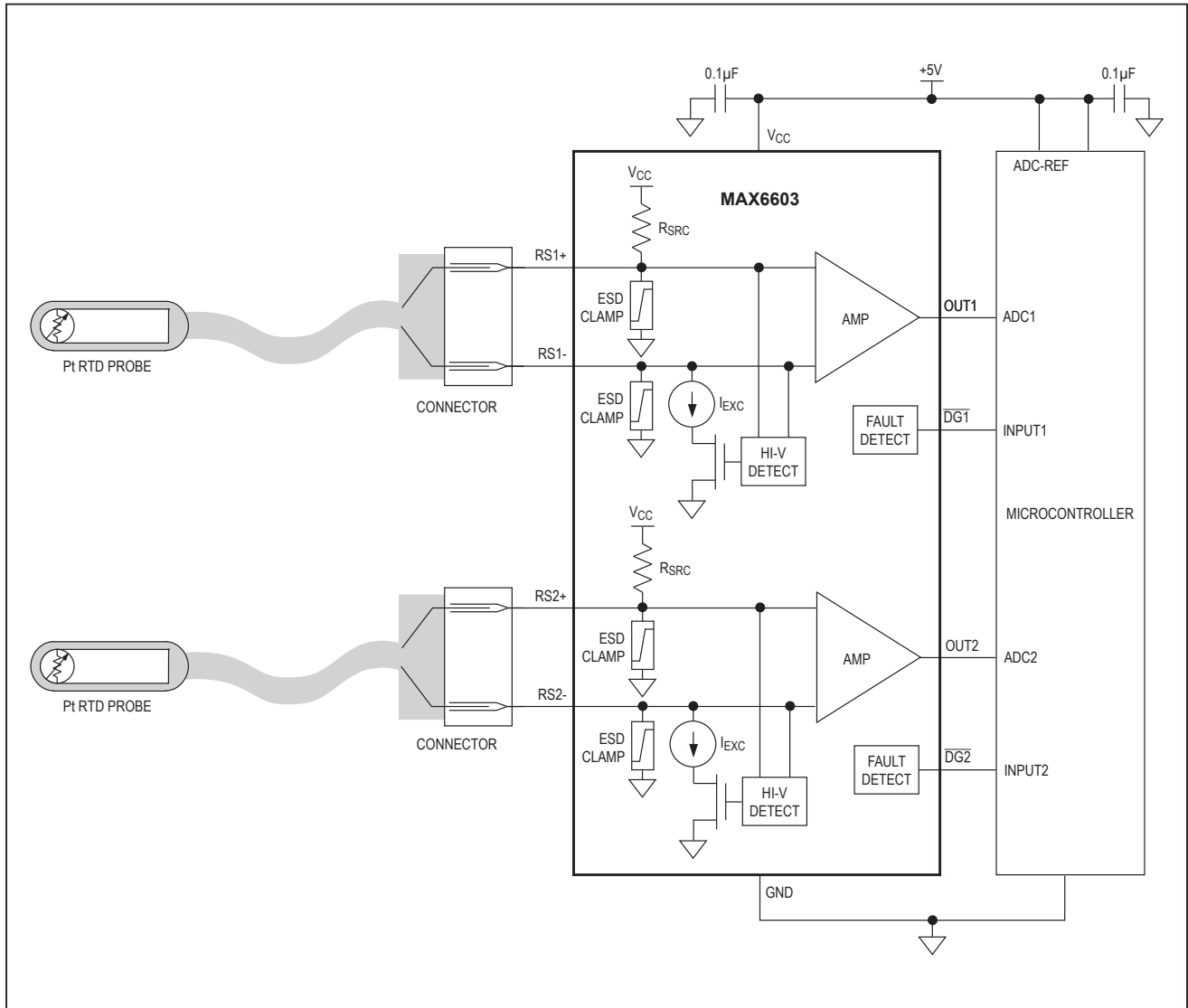

Figure 3. A Typical Application Circuit with Ratiometric Output Coupled to Ratiometric Microcontroller ADC

Package Information

For the latest package outline information and land patterns (footprints), go to www.maximintegrated.com/packages. Note that a “+”, “#”, or “-” in the package code indicates RoHS status only. Package drawings may show a different suffix character, but the drawing pertains to the package regardless of RoHS status.

PACKAGE TYPE	PACKAGE CODE	OUTLINE NO.	LAND PATTERN NO.
10 TDFN	T1033+1	21-0137	90-0003

MAX6603

Dual-Channel, Platinum RTD-to-Voltage
Signal Conditioner

Revision History

REVISION NUMBER	REVISION DATE	DESCRIPTION	PAGES CHANGED
0	4/06	Initial release	—
1	4/14	No /V OPNs; removed Automotive reference from <i>Applications</i> section	1

For pricing, delivery, and ordering information, please contact Maxim Direct at 1-888-629-4642, or visit Maxim Integrated's website at www.maximintegrated.com.

Maxim Integrated cannot assume responsibility for use of any circuitry other than circuitry entirely embodied in a Maxim Integrated product. No circuit patent licenses are implied. Maxim Integrated reserves the right to change the circuitry and specifications without notice at any time. The parametric values (min and max limits) shown in the Electrical Characteristics table are guaranteed. Other parametric values quoted in this data sheet are provided for guidance.