

## Excellent Integrated System Limited

Stocking Distributor

Click to view price, real time Inventory, Delivery & Lifecycle Information:

[Maxim Integrated](#)  
[MAX807MEPE+](#)

For any questions, you can email us directly:

[sales@integrated-circuit.com](mailto:sales@integrated-circuit.com)

19-0433; Rev 4; 11/05



# Full-Featured $\mu$ P Supervisory Circuit with $\pm 1.5\%$ Reset Accuracy

MAX807L/M/N

## General Description

The MAX807 microprocessor ( $\mu$ P) supervisory circuit reduces the complexity and number of components needed to monitor power-supply and battery-control functions in  $\mu$ P systems. A 70 $\mu$ A supply current makes the MAX807 ideal for use in portable equipment, while a 2ns chip-enable propagation delay and 250mA output current capability (20mA in battery-backup mode) make it suitable for larger, higher-performance equipment.

The MAX807 comes in 16-pin DIP, SO, and TSSOP packages, and provides the following functions:

- $\mu$ P reset. The active-low RESET output is asserted during power-up, power-down, and brownout conditions, and is guaranteed to be in the correct state for  $V_{CC}$  down to 1V.
- Active-high RESET output.
- Manual-reset input.
- Two-stage power-fail warning. A separate low-line comparator compares  $V_{CC}$  to a threshold 52mV above the reset threshold. This low-line comparator is more accurate than those in previous  $\mu$ P supervisors.
- Backup-battery switchover for CMOS RAM, real-time clocks,  $\mu$ Ps, or other low-power logic.
- Write protection of CMOS RAM or EEPROM.
- 2.275V threshold detector provides for power-fail warning and low-battery detection, or monitors a power supply other than +5V.
- BATT OK status flag indicates that the backup-battery voltage is above +2.275V.
- Watchdog-fault output—asserted if the watchdog input has not been toggled within a preset timeout period.

## Applications

- Computers
- Controllers
- Intelligent Instruments
- Critical  $\mu$ P Power Monitoring
- Portable/Battery-Powered Equipment

## Features

- ◆ Precision 4.675V (MAX807L), 4.425V (MAX807M), or 4.575V (MAX807N) Voltage Monitoring
- ◆ 200ms Power-OK/Reset Time Delay
- ◆ RESET and RESET Outputs
- ◆ Independent Watchdog Timer
- ◆ 1 $\mu$ A Standby Current
- ◆ Power Switching  
250mA in  $V_{CC}$  Mode  
20mA in Battery-Backup Mode
- ◆ On-Board Gating of Chip-Enable Signals;  
2ns CE Gate Propagation Delay
- ◆ MaxCap® and SuperCap® Compatible
- ◆ Voltage Monitor for Power Fail
- ◆ Backup-Battery Monitor
- ◆ Guaranteed RESET Valid to  $V_{CC} = 1V$
- ◆  $\pm 1.5\%$  Low-Line Threshold Accuracy 52mV above Reset Threshold

## Pin Configuration

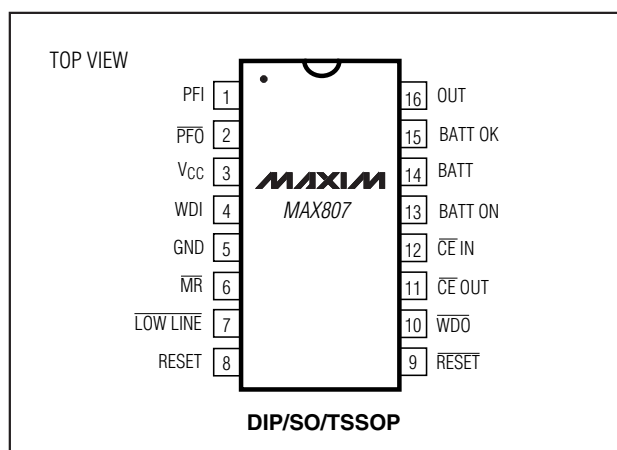

Ordering Information and Typical Operating Circuit appear at end of data sheet.

SuperCap is a registered trademark of Baknor Industries. MaxCap is a registered trademark of Cesiwid, Inc.



Maxim Integrated Products 1

For pricing, delivery, and ordering information, please contact Maxim/Dallas Direct! at 1-888-629-4642, or visit Maxim's website at www.maxim-ic.com.

# Full-Featured $\mu$ P Supervisory Circuit with $\pm 1.5\%$ Reset Accuracy

MAX807L/M/N

## ABSOLUTE MAXIMUM RATINGS

Input Voltages (with respect to GND)

V <sub>CC</sub> .....	-0.3V to 6V
V <sub>BATT</sub> .....	-0.3V to 6V
All Other Inputs .....	-0.3V to (V <sub>OUT</sub> + 0.3V)

Input Current

V <sub>CC</sub> Peak .....	1.0A
V <sub>CC</sub> Continuous .....	500mA
I <sub>BATT</sub> Peak .....	250mA
I <sub>BATT</sub> Continuous .....	50mA
GND .....	50mA
All Other Inputs .....	50mA

Continuous Power Dissipation (T<sub>A</sub> = +70°C)

Plastic DIP (derate 10.53mW/°C above +70°C) .....	842mW
Wide SO (derate 9.52mW/°C above +70°C) .....	762mW
CERDIP (derate 10.00mW/°C above +70°C) .....	800mW
TSSOP (derate 6.70 mW/°C above +70°C) .....	533mW

Operating Temperature Ranges

MAX807_C_E .....	0°C to +70°C
MAX807_E_E .....	-40°C to +85°C
MAX807_MJE .....	-55°C to +125°C

Storage Temperature Range .....

Lead Temperature (soldering, 10s) .....

Stresses beyond those listed under "Absolute Maximum Ratings" may cause permanent damage to the device. These are stress ratings only, and functional operation of the device at these or any other conditions beyond those indicated in the operational sections of the specifications is not implied. Exposure to absolute maximum rating conditions for extended periods may affect device reliability.

## ELECTRICAL CHARACTERISTICS

(V<sub>CC</sub> = 4.60V to 5.5V for the MAX807L, V<sub>CC</sub> = 4.50V to 5.5V for the MAX807N, V<sub>CC</sub> = 4.35V to 5.5V for the MAX807M, V<sub>BATT</sub> = 2.8V, V<sub>PFI</sub> = 0V, T<sub>A</sub> = T<sub>MIN</sub> to T<sub>MAX</sub>. Typical values are tested with V<sub>CC</sub> = 5V and T<sub>A</sub> = +25°C, unless otherwise noted.)

PARAMETER	SYMBOL	CONDITIONS	MIN	TYP	MAX	UNITS
Operating Voltage Range V <sub>BATT</sub> , V <sub>CC</sub> (Note 1)			0		5.5	V
V <sub>OUT</sub> in Normal Operating Mode		V <sub>CC</sub> = 4.5V	I <sub>OUT</sub> = 25mA	V <sub>CC</sub> - 0.02		V
			I <sub>OUT</sub> = 250mA, MAX807C/E	V <sub>CC</sub> - 0.35	V <sub>CC</sub> - 0.22	
			I <sub>OUT</sub> = 250mA, MAX807M	V <sub>CC</sub> - 0.45		
		V <sub>CC</sub> = 3V, V <sub>BATT</sub> = 2.8V, I <sub>OUT</sub> = 100mA	V <sub>CC</sub> - 0.25	V <sub>CC</sub> - 0.12		
V <sub>CC</sub> to OUT On-Resistance		V <sub>CC</sub> = 4.5V, I <sub>OUT</sub> = 250mA	MAX807C/E	1.0	1.4	Ω
			MAX807M		1.8	
		V <sub>CC</sub> = 3V, I <sub>OUT</sub> = 100mA	1.2	2.5		
V <sub>OUT</sub> in Battery-Backup Mode		V <sub>BATT</sub> = 4.5V, I <sub>OUT</sub> = 20mA, V <sub>CC</sub> = 0V	V <sub>BATT</sub> - 0.17		V	
		V <sub>BATT</sub> = 2.8V, I <sub>OUT</sub> = 10mA, V <sub>CC</sub> = 0V	V <sub>BATT</sub> - 0.25	V <sub>BATT</sub> - 0.12		
		V <sub>BATT</sub> = 2.0V, I <sub>OUT</sub> = 5mA, V <sub>CC</sub> = 0V	V <sub>BATT</sub> - 0.20	V <sub>BATT</sub> - 0.08		
BATT to OUT On-Resistance		V <sub>BATT</sub> = 4.5V, I <sub>OUT</sub> = 20mA	8.5		Ω	
		V <sub>BATT</sub> = 2.8V, I <sub>OUT</sub> = 10mA	12	25		
		V <sub>BATT</sub> = 2.0V, I <sub>OUT</sub> = 5mA	16	40		
Supply Current in Normal Operating Mode (excludes I <sub>OUT</sub> )				70	110	μA
Supply Current in Battery-Backup Mode (excludes I <sub>OUT</sub> ) (Note 2)		V <sub>CC</sub> = 0V, V <sub>BATT</sub> = 2.8V	T <sub>A</sub> = +25°C	0.4	1	μA
			MAX807C/E		5	
			MAX807M		50	
BATT Standby Current (Note 3)		V <sub>BATT</sub> = 2.8V, V <sub>CC</sub> = 3.0V	T <sub>A</sub> = +25°C	-0.1	0.1	μA
			T <sub>A</sub> = T <sub>MIN</sub> to T <sub>MAX</sub>	-1.0	1.0	
Battery-Switchover Threshold		V <sub>BATT</sub> = 2.8V	Power up	V <sub>BATT</sub> + 0.05		V
			Power down	V <sub>BATT</sub>		
Battery-Switchover Hysteresis				50		mV
BATT ON Output, Low Voltage		V <sub>RST</sub> (max), I <sub>SINK</sub> = 3.2mA		0.1	0.4	V
BATT ON Output, High Voltage		V <sub>CC</sub> = 0V, I <sub>SOURCE</sub> = 0.1mA, V <sub>BATT</sub> = 2.8V	2	2.7		V

## Full-Featured $\mu$ P Supervisory Circuit with $\pm 1.5\%$ Reset Accuracy

### ELECTRICAL CHARACTERISTICS (continued)

( $V_{CC} = 4.60V$  to  $5.5V$  for the MAX807L,  $V_{CC} = 4.50V$  to  $5.5V$  for the MAX807N,  $V_{CC} = 4.35V$  to  $5.5V$  for the MAX807M,  $V_{BATT} = 2.8V$ ,  $V_{PFI} = 0V$ ,  $T_A = T_{MIN}$  to  $T_{MAX}$ . Typical values are tested with  $V_{CC} = 5V$  and  $T_A = +25^\circ C$ , unless otherwise noted.)

PARAMETER	SYMBOL	CONDITIONS		MIN	TYP	MAX	UNITS
BATT ON Output Short-Circuit Current		Sink current			70		mA
		Source current, $V_{CC} = 0V$ , $V_{BATT} = 2.8V$			5		
<b>RESET, LOW LINE, AND WATCHDOG TIMER</b>							
Reset Threshold	VRST	V <sub>CC</sub> rising and falling	MAX807L	4.600	4.675	4.750	V
			MAX807N	4.500	4.575	4.650	
			MAX807M	4.350	4.425	4.500	
Reset Threshold Hysteresis				13			mV
LOW LINE to RESET Threshold Voltage	V <sub>LR</sub>	V <sub>CC</sub> falling		30	52	70	mV
LOW LINE Threshold, V <sub>CC</sub> Rising	V <sub>LL</sub>	MAX807L			4.73	4.81	V
		MAX807N			4.63	4.71	
		MAX807M			4.48	4.56	
V <sub>CC</sub> to RESET Delay		V <sub>CC</sub> falling at 1mV/ $\mu$ s		26			$\mu$ s
V <sub>CC</sub> to LOW LINE Delay		V <sub>CC</sub> falling at 1mV/ $\mu$ s		24			$\mu$ s
RESET Active-Timeout Period	t <sub>RP</sub>	V <sub>CC</sub> rising		140	200	280	ms
Watchdog-Timeout Period	t <sub>WD</sub>			1.12	1.6	2.24	s
Minimum Watchdog Input Pulse Width		V <sub>IL</sub> = 0.8V, V <sub>IH</sub> = 0.75 x V <sub>CC</sub>		100			ns
RESET Output Voltage		I <sub>SINK</sub> = 50 $\mu$ A, V <sub>BATT</sub> = 0V, V <sub>CC</sub> falling	V <sub>CC</sub> = 1V, MAX807_C			0.3	V
			V <sub>CC</sub> = 1.2V, MAX807_E/M			0.3	
		I <sub>SINK</sub> = 3.2mA, V <sub>CC</sub> = 4.25V		0.1	0.4		
		I <sub>SOURCE</sub> = 0.1mA	V <sub>CC</sub> - 1.5	V <sub>CC</sub> - 0.1			
RESET Output Short-Circuit Current	I <sub>SC</sub>	Output sink current, V <sub>CC</sub> = 4.25V		60			mA
		Output source current		1.6			
RESET Output Voltage		I <sub>SINK</sub> = 3.2mA				0.4	V
		I <sub>SOURCE</sub> = 5mA	V <sub>CC</sub> - 1.5				
RESET Output Short-Circuit Current	I <sub>SC</sub>	Output sink current		60			mA
		Output source current, V <sub>CC</sub> = 4.25V		15			
LOW LINE Output Voltage		I <sub>SINK</sub> = 3.2mA, V <sub>CC</sub> = 4.25V				0.4	V
		I <sub>SOURCE</sub> = 5mA	V <sub>CC</sub> - 1.5				
LOW LINE Output Short-Circuit Current	I <sub>SC</sub>	Output sink current, V <sub>CC</sub> = 4.25V		28			mA
		Output source current		20			
WDO Output Voltage		I <sub>SINK</sub> = 3.2mA				0.4	V
		I <sub>SOURCE</sub> = 5mA	V <sub>CC</sub> - 1.5				
WDO Output Short-Circuit Current	I <sub>SC</sub>	Output sink current		35			mA
		Output source current		20			
WDI Threshold Voltage (Note 4)	V <sub>IH</sub>		0.75 x V <sub>CC</sub>				V
	V <sub>IL</sub>					0.8	
WDI Input Current		Reset deasserted, WDI = 0V		-50	-10		$\mu$ A
		Reset deasserted, WDI = V <sub>CC</sub>			16	50	

MAX807L/M/N

# Full-Featured $\mu$ P Supervisory Circuit with $\pm 1.5\%$ Reset Accuracy

MAX807L/M/N

## ELECTRICAL CHARACTERISTICS (continued)

( $V_{CC} = 4.60V$  to  $5.5V$  for the MAX807L,  $V_{CC} = 4.50V$  to  $5.5V$  for the MAX807N,  $V_{CC} = 4.35V$  to  $5.5V$  for the MAX807M,  $V_{BATT} = 2.8V$ ,  $V_{PFI} = 0V$ ,  $T_A = T_{MIN}$  to  $T_{MAX}$ . Typical values are tested with  $V_{CC} = 5V$  and  $T_A = +25^\circ C$ , unless otherwise noted.)

PARAMETER	SYMBOL	CONDITIONS	MIN	TYP	MAX	UNITS
PFI Input Threshold	VPFI	VPFI falling	2.20	2.265	2.33	V
		VPFI rising	2.22	2.285	2.35	
PFI Hysteresis				20		mV
PFI Leakage Current				$\pm 0.005$	$\pm 40$	nA
PFI to PFO Delay (Note 5)		$V_{OD} = 30mV$ , VPFI falling		14		$\mu s$
<b>CHIP-ENABLE GATING</b>						
CE IN Leakage Current		Disabled mode, MR = 0V		$\pm 0.00002$	$\pm 1$	$\mu A$
CE IN to CE OUT Resistance (Note 6)		Enabled mode, $V_{CC} = V_{RST} (max)$		75	150	$\Omega$
CE OUT Short-Circuit Current (RESET Active)		$V_{CC} = 5V$ , disabled mode, CE OUT = 0, MR = 0V		17		mA
CE IN to CE OUT Propagation Delay (Note 7)		$V_{CC} = 5V$ , $C_{LOAD} = 50pF$ , $50\Omega$ source impedance driver		2	8	ns
CE OUT Output Voltage High (RESET Active)		Disabled mode, MR = 0V	$V_{CC} = 5V$ , $I_{OUT} = 2mA$	3.5		V
			$V_{CC} = 0V$ , $I_{OUT} = 10\mu A$	$V_{BATT} - 0.1$	$V_{BATT}$	
RESET to CE OUT Delay		$V_{CC}$ falling		28		$\mu s$
<b>MANUAL RESET INPUT</b>						
MR Minimum Pulse Input			1			$\mu s$
MR-to-RESET Propagation Delay				170		ns
MR Threshold	$V_{IH}$		2.4		0.8	V
	$V_{IL}$					
MR Pullup Current		MR = 0V	50	100	200	$\mu A$
<b>BATT OK COMPARATOR</b>						
BATT OK Threshold	$V_{BOK}$		2.200	2.265	2.350	V
BATT OK Hysteresis				20		mV
<b>LOGIC OUTPUTS</b>						
Output Voltage (PFO, BATT OK)	$V_{OL}$	$I_{SINK} = 3.2mA$	0.4		V	
	$V_{OH}$	$I_{SOURCE} = 5mA$	$V_{CC} - 1.5$			
Output Short-Circuit Current	ISC	Output sink current	35		mA	
		Output source current	20			

**Note 1:** Either  $V_{CC}$  or  $V_{BATT}$  can go to 0 if the other is greater than 2.0V.

**Note 2:** The supply current drawn by the MAX807 from the battery (excluding  $I_{OUT}$ ) typically goes to  $15\mu A$  when  $(V_{BATT} - 0.1V) < V_{CC} < V_{BATT}$ . In most applications, this is a brief period as  $V_{CC}$  falls through this region (see *Typical Operating Characteristics*).

**Note 3:** "+" = battery discharging current, "-" = battery charging current.

**Note 4:** WDI is internally connected to a voltage-divider between  $V_{CC}$  and GND. If unconnected, WDI is driven to 1.8V (typical), disabling the watchdog function.

**Note 5:** Overdrive ( $V_{OD}$ ) is measured from center of hysteresis band.

**Note 6:** The chip-enable resistance is tested with  $V_{CE IN} = V_{CC}/2$ , and  $I_{CE IN} = 1mA$ .

**Note 7:** The chip-enable propagation delay is measured from the 50% point at CE IN to the 50% point at CE OUT.

# Full-Featured $\mu$ P Supervisory Circuit with $\pm 1.5\%$ Reset Accuracy

## Typical Operating Characteristics

( $V_{CC} = 5V$ ,  $V_{BATT} = 2.8V$ ,  $PFI = 0$ , no load,  $T_A = +25^\circ C$ , unless otherwise noted.)

**MAX807L/M/N**

**$V_{CC}$  SUPPLY CURRENT vs. TEMPERATURE (NORMAL OPERATING MODE)**

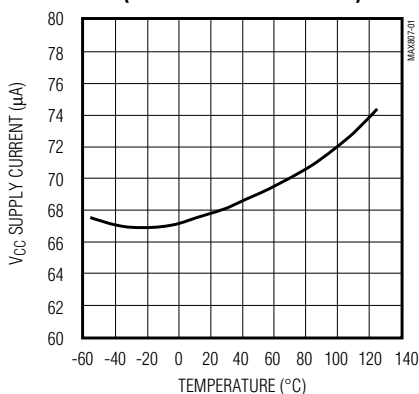

**BATTERY SUPPLY CURRENT vs. TEMPERATURE (BATTERY-BACKUP MODE)**

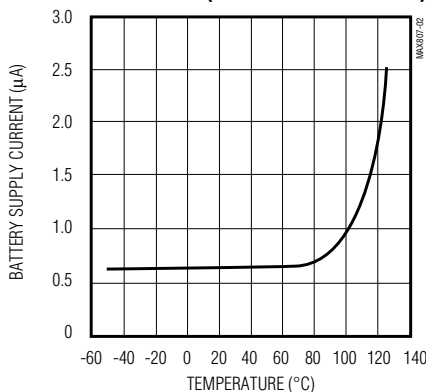

**CHIP-ENABLE PROPAGATION DELAY vs. TEMPERATURE**

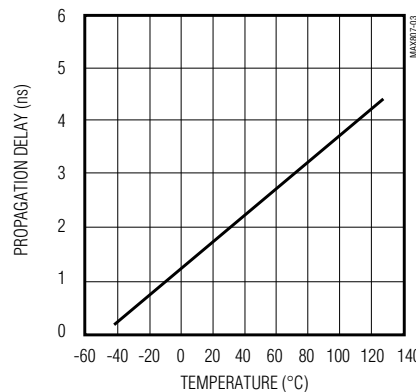

**BATT-TO-OUT ON-RESISTANCE vs. TEMPERATURE**

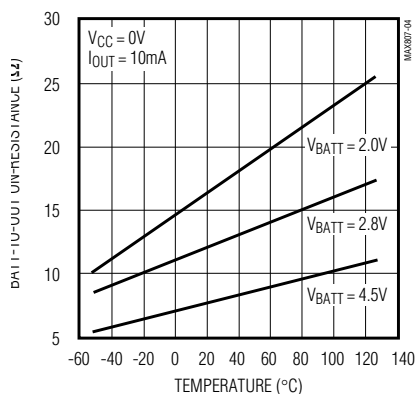

**$V_{CC}$ -TO-OUT ON-RESISTANCE vs. TEMPERATURE**

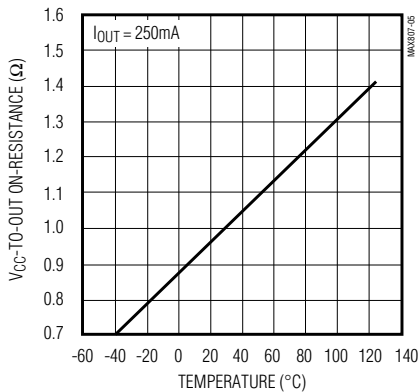

**PFI THRESHOLD vs. TEMPERATURE ( $V_{PFI}$  FALLING)**

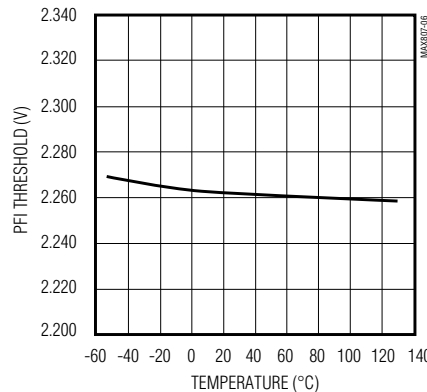

**RESET THRESHOLD vs. TEMPERATURE**

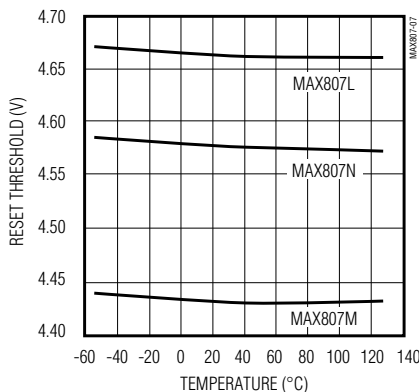

**RESET TIMEOUT PERIOD vs. TEMPERATURE ( $V_{CC}$  RISING)**

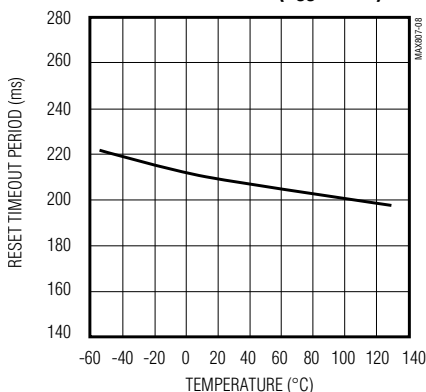

**LOW LINE-TO-RESET THRESHOLD vs. TEMPERATURE ( $V_{CC}$  FALLING)**

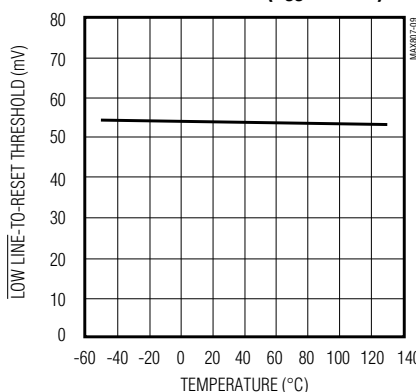

# Full-Featured $\mu$ P Supervisory Circuit with $\pm 1.5\%$ Reset Accuracy

## Typical Operating Characteristics (continued)

( $V_{CC} = 5V$ ,  $V_{BATT} = 2.8V$ ,  $PFI = 0$ , no load,  $T_A = +25^\circ C$ , unless otherwise noted.)

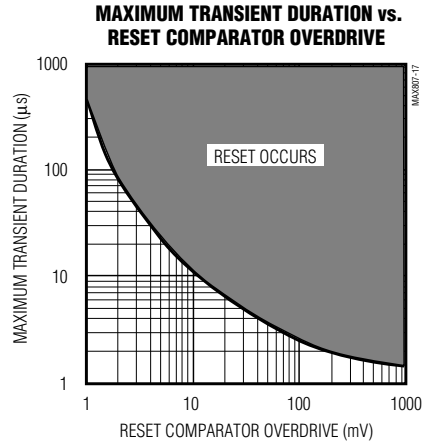
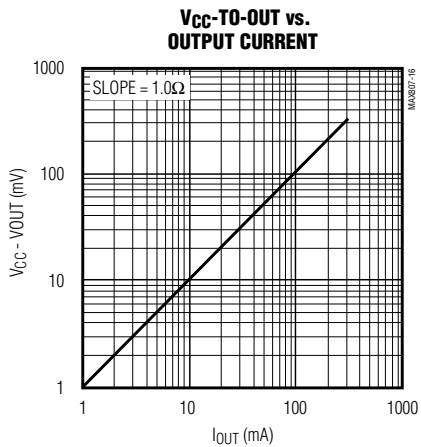
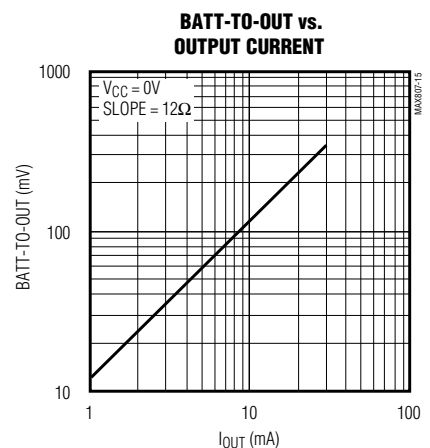
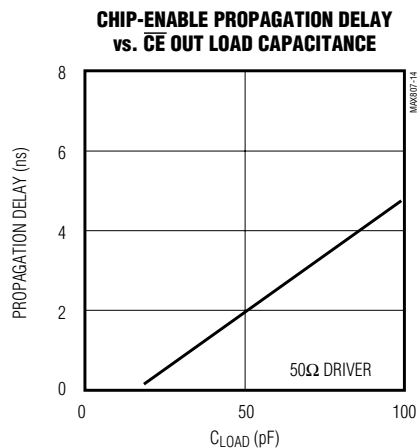
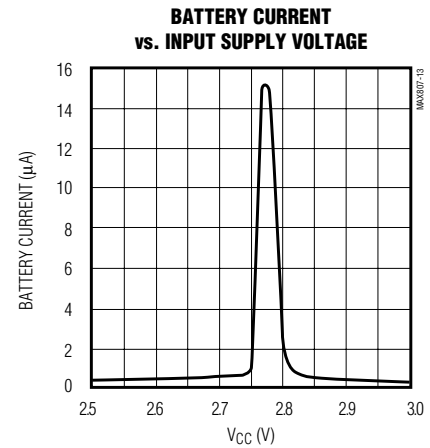
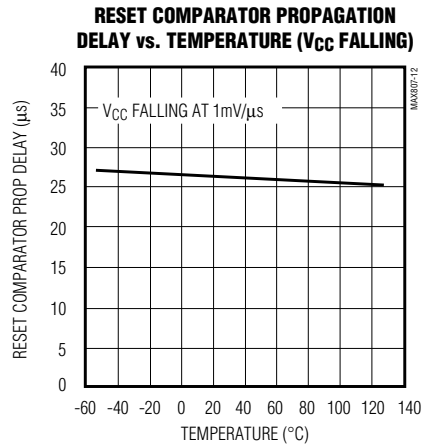
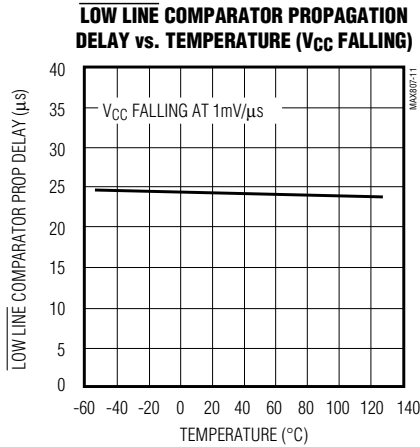
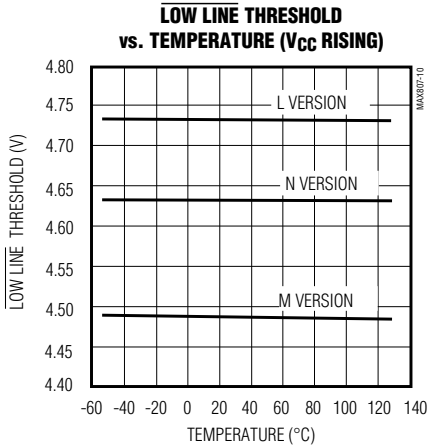

## Full-Featured $\mu$ P Supervisory Circuit with $\pm 1.5\%$ Reset Accuracy

### Pin Description

**MAX807L/M/N**

PIN	NAME	FUNCTION
1	PFI	Power-Fail Input. When PFI is less than $V_{PFT}$ (2.265V), PFO goes low. Connect to ground when unused.
2	PFO	Power-Fail Output. This CMOS-logic output goes low when PFI is less than $V_{PFT}$ (2.265V). Valid for $V_{CC} \geq 4V$ . PFO swings between $V_{CC}$ and GND.
3	$V_{CC}$	Input Supply Voltage, nominally +5V. Bypass with a 0.1 $\mu$ F capacitor to GND.
4	WDI	Watchdog Input. If WDI remains high or low longer than the watchdog-timeout period (1.6s, typ), WDO goes low. Leave unconnected to disable the watchdog function.
5	GND	Ground
6	MR	Manual-Reset Input. A logic low on MR asserts reset. Reset remains asserted as long as MR remains low and for 200ms after MR returns high. MR is an active-low input with an internal pullup to $V_{CC}$ . It can be driven using TTL or CMOS logic, or shorted to ground with a switch. Connect to $V_{CC}$ , or leave unconnected if not used.
7	LOW LINE	Low-Line Comparator Output. This CMOS-logic output goes low when $V_{CC}$ falls to 52mV above the reset threshold. Use this output to generate an NMI to initiate an orderly shutdown routine when $V_{CC}$ is falling. LOW LINE swings between $V_{CC}$ and GND.
8	RESET	Active-High Reset Output. RESET is the inverse of RESET. It is a CMOS output that sources and sinks current. RESET swings between $V_{CC}$ and GND.
9	RESET	Active-Low Reset Output. RESET is triggered and stays low when $V_{CC}$ is below the reset threshold or when MR is low. It remains low 200ms after $V_{CC}$ rises above the reset threshold or MR returns high. RESET has a strong pulldown but a relatively weak pullup, and can be wire-OR connected to logic gates. Valid for $V_{CC} \geq 1V$ . RESET swings between $V_{CC}$ and GND.
10	WDO	Watchdog Output. This CMOS-logic output goes low if WDI remains high or low longer than the watchdog-timeout period ( $t_{WD}$ ), and remains low until the next transition of WDI. WDO remains high if WDI is unconnected. WDO is high during reset. WDO swings between $V_{CC}$ and GND. Connect WDO to MR to generate resets during watchdog faults.
11	CE OUT	Chip-Enable Output. Output to the chip-enable gating circuit. CE OUT is pulled up to the higher of $V_{CC}$ or $V_{BATT}$ , when the chip-enable gate is disabled.
12	CE IN	Chip-Enable Input
13	BATT ON	Battery-On Output. CMOS-logic output/external bypass switch driver. High when OUT is connected to BATT and low when OUT is connected to $V_{CC}$ . Connect the base of a PNP transistor or gate of a PMOS transistor to BATT ON for $I_{OUT}$ requirements exceeding 250mA. BATT ON swings between the higher of $V_{CC}$ and $V_{BATT}$ and GND.
14	BATT	Backup-Battery Input. When $V_{CC}$ falls below the reset threshold and $V_{BATT}$ , OUT switches from $V_{CC}$ to BATT. $V_{BATT}$ may exceed $V_{CC}$ . The battery can be removed while the MAX807 is powered-up, provided BATT is bypassed with a 0.1 $\mu$ F capacitor to GND. If no battery is used, connect BATT to ground, and connect $V_{CC}$ and OUT together.
15	BATT OK	Battery-OK Signal Output. High in normal operating mode when $V_{BATT}$ exceeds $V_{BOK}$ (2.265V). Valid for $V_{CC} \geq 4V$ .
16	OUT	Output Supply Voltage to CMOS RAM. When $V_{CC}$ exceeds the reset threshold or $V_{CC} > V_{BATT}$ , OUT is connected to $V_{CC}$ . When $V_{CC}$ falls below the reset threshold and $V_{BATT}$ , OUT connects to BATT. Bypass OUT with a 0.1 $\mu$ F capacitor to GND.

# Full-Featured $\mu$ P Supervisory Circuit with $\pm 1.5\%$ Reset Accuracy

## Detailed Description

The MAX807  $\mu$ P supervisory circuit provides power-supply monitoring, backup-battery switchover, and program execution watchdog functions in  $\mu$ P systems (Figure 1). Use of BiCMOS technology results in an improved 1.5% reset-threshold precision, while keeping supply currents typically below 70 $\mu$ A. The MAX807 is intended for battery-powered applications that require high reset-threshold precision, allowing a wide power-supply operating range while preventing the system from operating below its specified voltage range.

## RESET and RESET Outputs

The MAX807's RESET output ensures that the  $\mu$ P powers up in a known state, and prevents code execution errors during power-down and brownout conditions. It accomplishes this by resetting the  $\mu$ P, terminating program execution when  $V_{CC}$  dips below the reset threshold or MR is pulled low. Each time RESET is asserted it stays low for the 200ms reset timeout period, which is set by an internal timer to ensure the  $\mu$ P has adequate time to return to an initial state. Any time  $V_{CC}$  goes below the reset threshold before the reset-timeout period is completed, the internal timer restarts. The watchdog timer can also initiate a reset if WDO is connected to MR (see the *Watchdog Input* section).

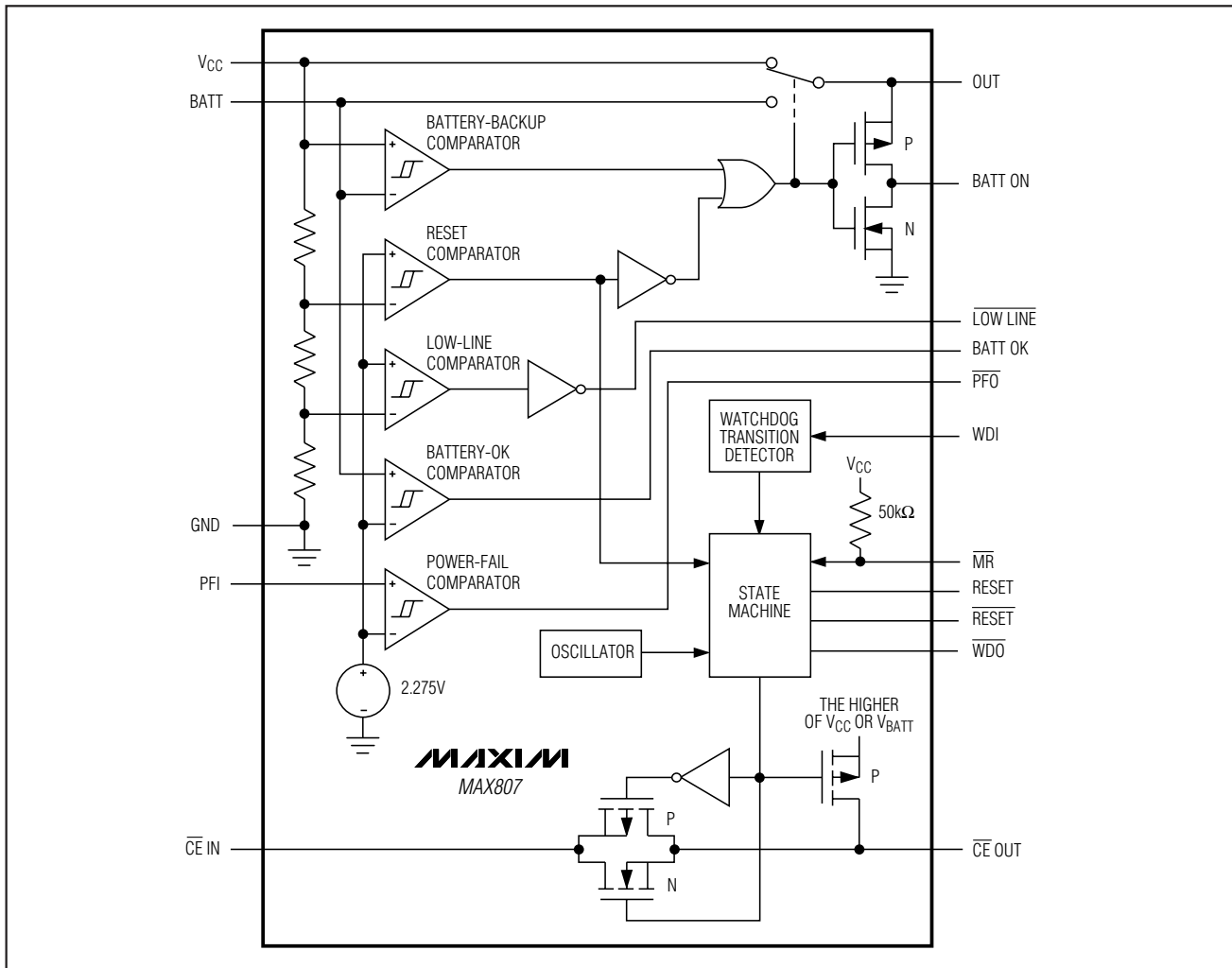

Figure 1. Block Diagram

# Full-Featured $\mu$ P Supervisory Circuit with $\pm 1.5\%$ Reset Accuracy

**MAX807L/M/N**

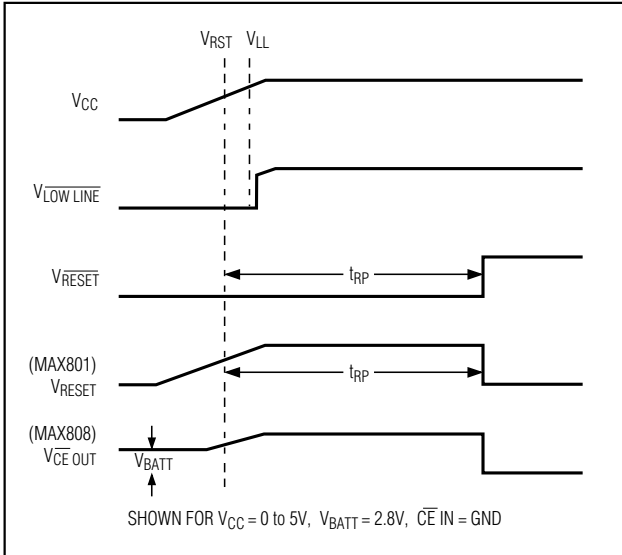

Figure 2a. Timing Diagram,  $V_{CC}$  Rising

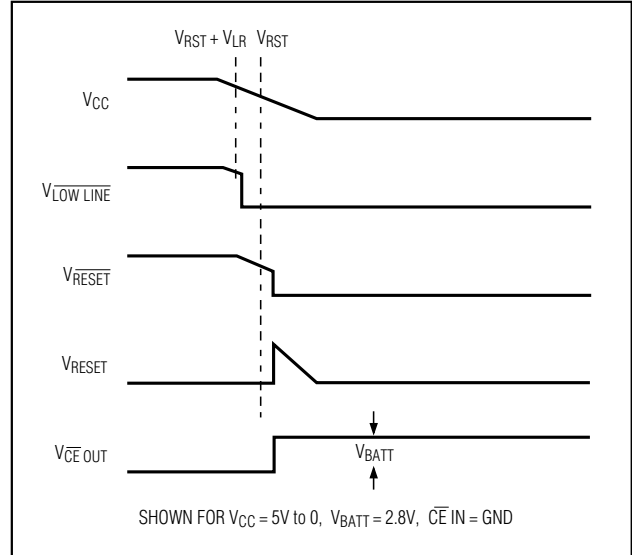

Figure 2b. Timing Diagram,  $V_{CC}$  Falling

The RESET output is active low and implemented with a strong pulldown/relatively weak pullup structure. It is guaranteed to be a logic low for  $0 < V_{CC} < V_{RST}$ , provided  $V_{BATT}$  is greater than 2V. Without a backup battery, RESET is guaranteed valid for  $V_{CC} \geq 1$ . It typically sinks 3.2mA at 0.1V saturation voltage in its active state.

The RESET output is the inverse of the RESETE output; it both sources and sinks current and cannot be wire-OR connected. Figure 2a shows a timing diagram with  $V_{CC}$  rising and Figure 2b shows  $V_{CC}$  falling.

### Manual Reset Input

Many  $\mu$ P-based products require manual-reset capability to allow an operator or test technician to initiate a reset. The Manual Reset (MR) input permits the generation of a reset in response to a logic low from a switch, WDO, or external circuitry. Reset remains asserted while MR is low, and for 200ms after MR returns high.

MR has an internal 50 $\mu$ A to 200 $\mu$ A pullup current, so it can be left open if it is not used. MR can be driven with TTL or CMOS-logic levels, or with open-drain/collector outputs. Connect a normally open momentary switch from MR to GND to create a manual-reset function; external debounce circuitry is not required. If MR is driven from long cables or if the device is used in a noisy environment, connect a 0.1 $\mu$ F capacitor from MR to ground to provide additional noise immunity. As shown in Figure 3, diode-ORed connections can be used to allow manual resets from multiple sources. Figure 4 shows the reset timing.

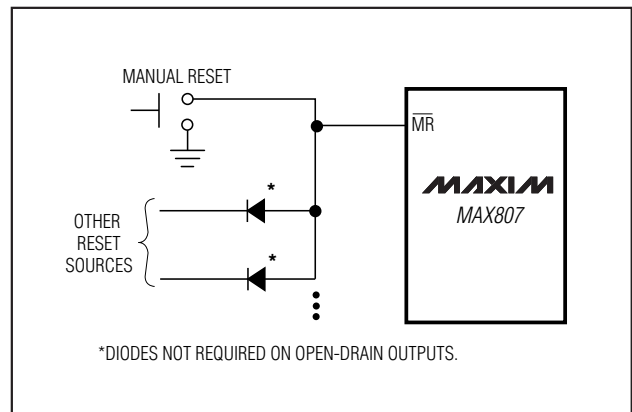

Figure 3. Diode "OR" Connections Allow Multiple Reset Sources to Connect to MR

### Watchdog Timer

#### Watchdog Input

The watchdog circuit monitors the  $\mu$ P's activity. If the  $\mu$ P does not toggle the watchdog input (WDI) within 1.6s, WDO goes low. The internal 1.6s timer is cleared and WDO returns high when reset is asserted or when a transition (low-to-high or high-to-low) occurs at WDI while RESETE is high. As long as reset is asserted, the timer remains cleared and does not count. As soon as reset is released, the timer starts counting (Figure 5). Supply current is typically reduced by 10 $\mu$ A when WDI is at a valid logic level.

# Full-Featured $\mu$ P Supervisory Circuit with $\pm 1.5\%$ Reset Accuracy

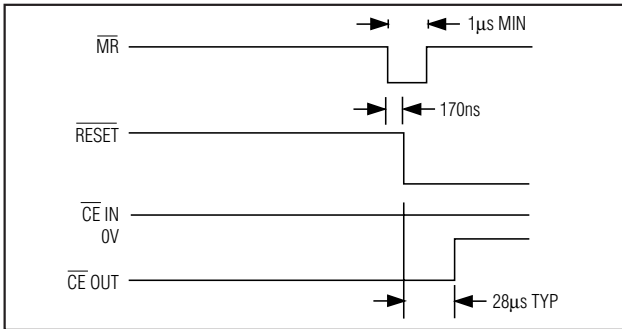

Figure 4. Manual-Reset Timing Diagram

### Watchdog Output

WDO remains high if there is a transition or pulse at WDI during the watchdog-timeout period. WDO goes low if no transition occurs at WDI during the watchdog-timeout period. The watchdog function is disabled and WDO is a logic high when VCC is below the reset threshold or WDI is an open circuit. To generate a system reset on every watchdog fault, diode-OR connect WDO to MR (Figure 6). When a watchdog fault occurs in this mode, WDO goes low, which pulls MR low, causing a reset pulse to be issued. As soon as reset is asserted, the watchdog timer clears and WDO returns high. With WDO connected to MR, a continuous high or low on WDI will cause 200ms reset pulses to be issued every 1.6s.

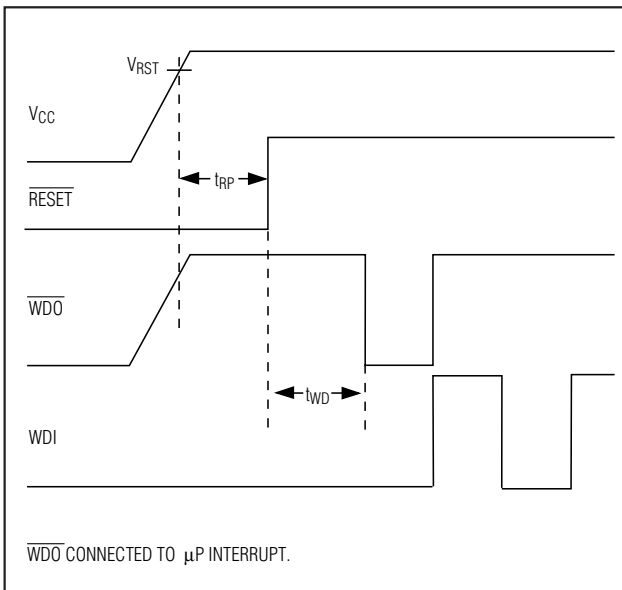

Figure 5. Watchdog Timing Relationship

### Chip-Enable Signal Gating

The MAX807 provides internal gating of chip-enable (CE) signals to prevent erroneous data from corrupting the CMOS RAM in the event of a power failure. During normal operation, the CE gate is enabled and passes all CE transitions. When reset is asserted, this path becomes disabled, preventing erroneous data from corrupting the CMOS RAM. The MAX807 uses a series transmission gate from the Chip-Enable Input (CE IN) to the Chip-Enable Output (CE OUT) (Figure 1).

The 8ns (max) chip-enable propagation from CE IN to CE OUT enables the MAX807 to be used with most  $\mu$ Ps.

### Chip-Enable Input

CE IN is high impedance (disabled mode) while RESET is asserted. During a power-down sequence when VCC passes the reset threshold, the CE transmission gate disables and CE IN becomes high impedance 28 $\mu$ s after reset is asserted (Figure 7). During a power-up sequence, CE IN remains high impedance (regardless of CE IN activity) until reset is deasserted following the reset-timeout period.

In the high-impedance mode, the leakage currents into this input are  $\pm 1\mu$ A (max) over temperature. In the low-impedance mode, the impedance of CE IN appears as a 75 $\Omega$  resistor in series with the load at CE OUT.

The propagation delay through the CE transmission gate depends on both the source impedance of the drive to CE IN and the capacitive loading on CE OUT

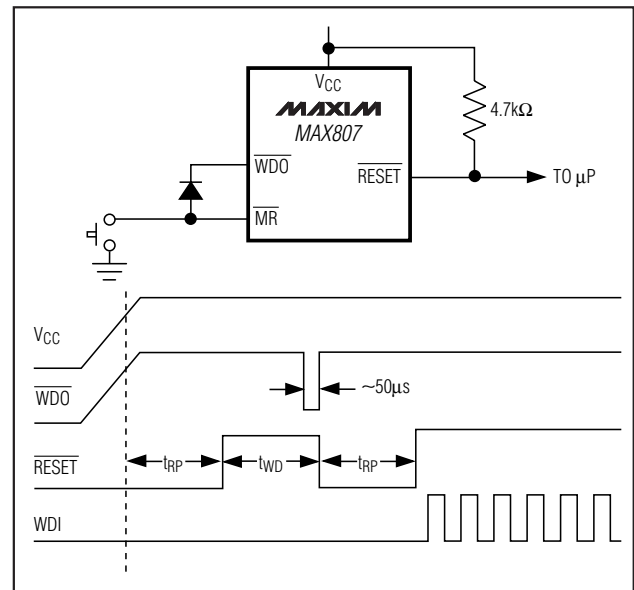

Figure 6. Generating a Reset on Each Watchdog Fault

## Full-Featured $\mu$ P Supervisory Circuit with $\pm 1.5\%$ Reset Accuracy

**MAX807L/M/N**

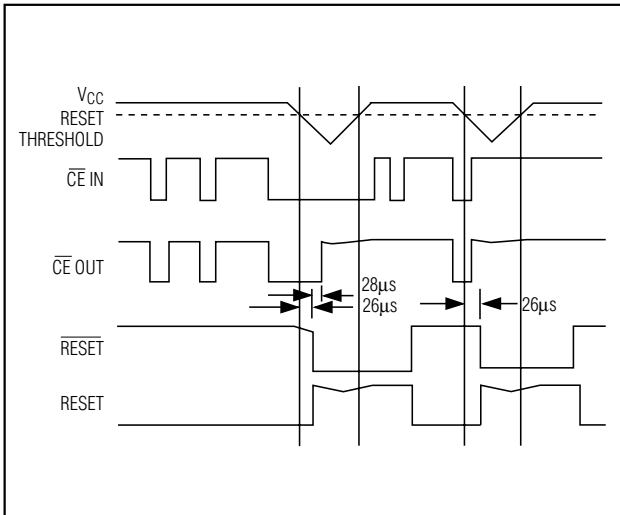

Figure 7. Reset and Chip-Enable Timing

(see the Chip-Enable Propagation Delay vs. CE OUT Load Capacitance graph in the *Typical Operating Characteristics*). The CE propagation delay is production tested from the 50% point on CE IN to the 50% point on CE OUT using a 50 $\Omega$  driver and 50pF of load capacitance (Figure 8). For minimum propagation delay, minimize the capacitive load at CE OUT and use a low output-impedance driver.

### Chip-Enable Output

In the enabled mode, the impedance of CE OUT is equivalent to 75 $\Omega$  in series with the source driving CE IN. In the disabled mode, the 75 $\Omega$  transmission gate is off and CE OUT is actively pulled to the higher of V<sub>CC</sub> or V<sub>BATT</sub>. This source turns off when the transmission gate is enabled.

### Low-Line Comparator

The low-line comparator monitors V<sub>CC</sub> with a threshold voltage typically 52mV above the reset threshold, with 13mV of hysteresis. Use LOW LINE to provide a non-maskable interrupt (NMI) to the  $\mu$ P when power begins to fall to initiate an orderly software shutdown routine.

In most battery-operated portable systems, reserve energy in the battery provides ample time to complete the shutdown routine once the low-line warning is encountered, and before reset asserts. If the system must contend with a more rapid V<sub>CC</sub> fall time—such as when the main battery is disconnected, a DC-DC converter shuts down, or a high-side switch is opened during normal operation—use capacitance on the V<sub>CC</sub> line to provide time to execute the shutdown routine (Figure 9). First calculate the worst-case time required for the system to perform its shutdown routine. Then, with the

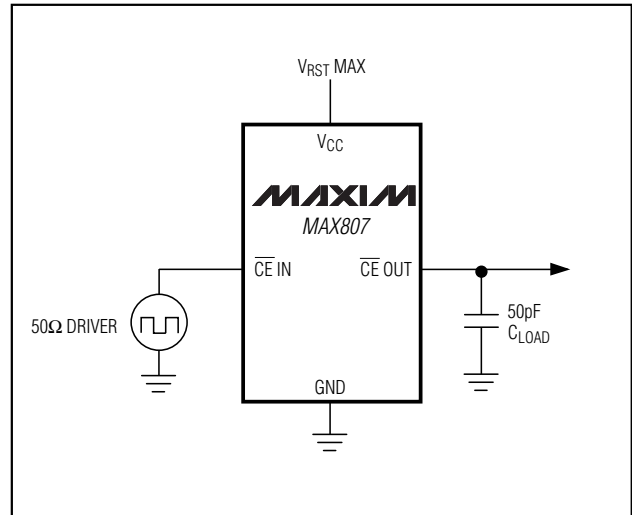

Figure 8. CE Propagation Delay Test Circuit

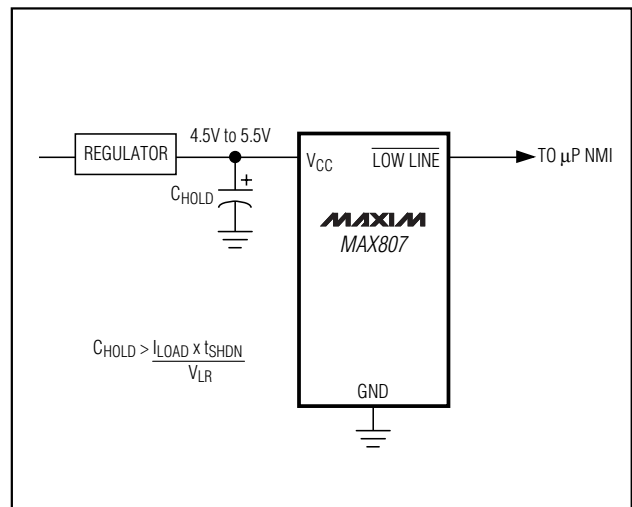

Figure 9. Using LOW LINE to Provide a Power-Fail Warning to the  $\mu$ P

worst-case shutdown time, the worst-case load current, and the minimum low-line to reset threshold (V<sub>LR(min)</sub>), calculate the amount of capacitance required to allow the shutdown routine to complete before reset is asserted:

$$C_{\text{HOLD}} = (I_{\text{LOAD}} \times t_{\text{SHDN}}) / V_{\text{LR}}(\text{min})$$

where t<sub>SHDN</sub> is the time required for the system to complete the shutdown routine, and includes the V<sub>CC</sub> to low-line propagation delay; and where I<sub>LOAD</sub> is the current being drained from the capacitor, V<sub>LR</sub> is the low-line to reset threshold.

## Full-Featured $\mu$ P Supervisory Circuit with $\pm 1.5\%$ Reset Accuracy

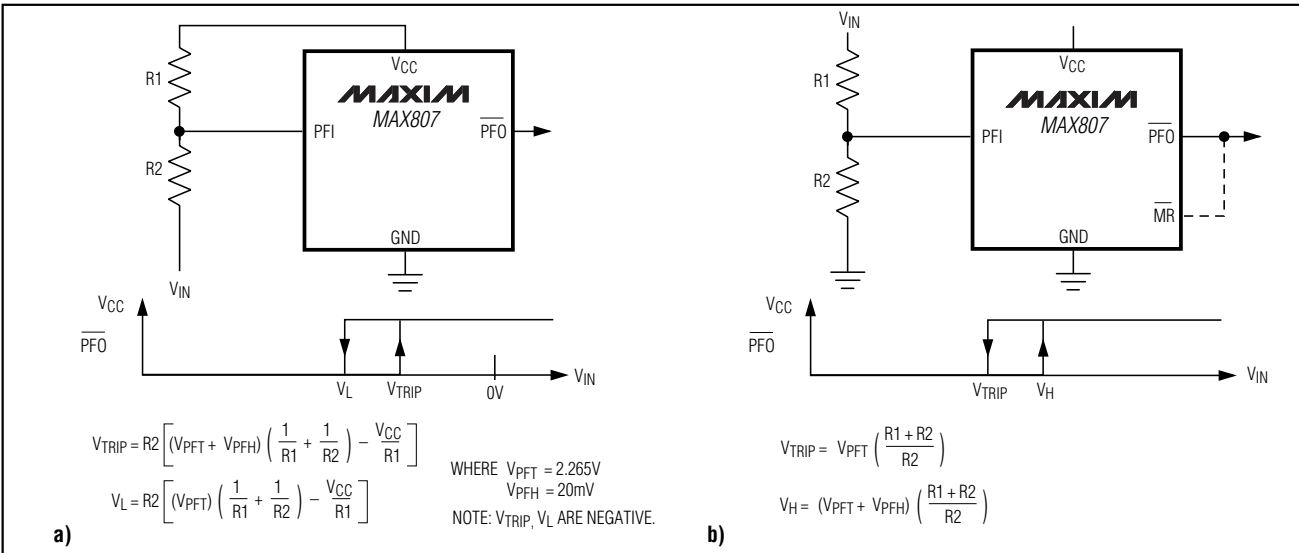

Figure 10. Using the Power-Fail Comparator to Monitor an Additional Power Supply: a)  $V_{IN}$  is Negative, b)  $V_{IN}$  is Positive

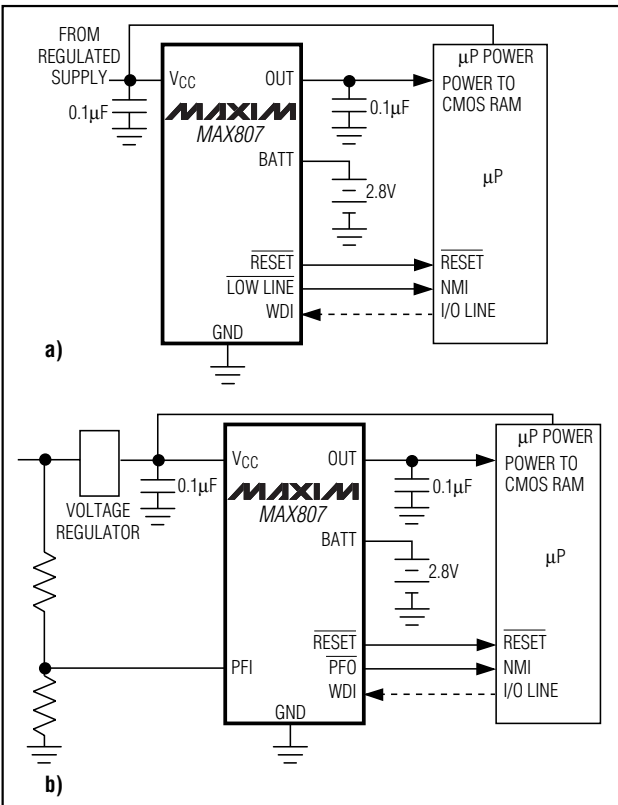

Figure 11. a) If the preregulated supply is inaccessible, LOW LINE generates the NMI for the  $\mu$ P. b) Use PFO to generate the  $\mu$ P NMI if the preregulated supply is accessible.

### Power-Fail Comparator

PFI is the noninverting input to an uncommitted comparator. If PFI is less than  $V_{PFT}$  (2.265V), PFO goes low. The power-fail comparator is intended to monitor the preregulated input of the power supply, providing an early power-fail warning so software can conduct an orderly shutdown. It can also be used to monitor supplies other than 5V. Set the power-fail threshold with a resistor-divider, as shown in Figure 10.

### Power-Fail Input

PFI is the input to the power-fail comparator. The typical comparator delay is 14 $\mu$ s from  $V_{IL}$  to  $V_{OL}$  (power failing), and 32 $\mu$ s from  $V_{IH}$  to  $V_{OH}$  (power being restored). If unused, connect this input to ground.

### Power-Fail Output

The Power-Fail Output (PFO) goes low when PFI goes below  $V_{PFT}$ . It typically sinks 3.2mA with a saturation voltage of 0.1V. With PFI above  $V_{PFT}$ , PFO is actively pulled to  $V_{CC}$ . Connecting PFI through a voltage-divider to a preregulated supply allows PFO to generate an NMI as the preregulated power begins to fall (Figure 11b). If the preregulated supply is inaccessible, use LOW LINE to generate the NMI (Figure 11a). The LOW LINE threshold is typically 52mV above the reset threshold (see the *Low-Line Comparator* section).

## Full-Featured $\mu$ P Supervisory Circuit with $\pm 1.5\%$ Reset Accuracy

**Table 1. Input and Output Status in Battery-Backup Mode**

PIN	NAME	FUNCTION
1	PFI	The power-fail comparator remains active in battery-backup mode for $V_{CC} \geq 4V$ .
2	PFO	The power-fail comparator remains active in battery-backup mode for $V_{CC} \geq 4V$ . Below 4V, PFO is forced low.
3	$V_{CC}$	Battery switchover comparator monitors $V_{CC}$ for active switchover.
4	WDI	WDI is ignored and goes high impedance
5	GND	Ground—0V reference for all signals
6	MR	MR is ignored
7	LOW LINE	Logic low
8	RESET	Logic high; the open-circuit output voltage is equal to $V_{CC}$ .
9	RESET	Logic low
10	WDO	Logic high. The open-circuit output voltage is equal to $V_{CC}$ .
11	CE OUT	Logic high. The open-circuit output voltage is equal to $V_{BATT}$ .
12	CE IN	High impedance
13	BATT ON	Logic high. The open-circuit output voltage is equal to $V_{BATT}$ .
14	BATT	Supply current is 1 $\mu$ A maximum for $V_{BATT} \leq 2.8V$ .
15	BATT OK	Logic high when $V_{BATT}$ exceeds 2.285V. Valid for $V_{CC} \geq 4V$ . Below 4V, BATT OK is forced low.
16	OUT	OUT is connected to BATT through two internal PMOS switches in series.

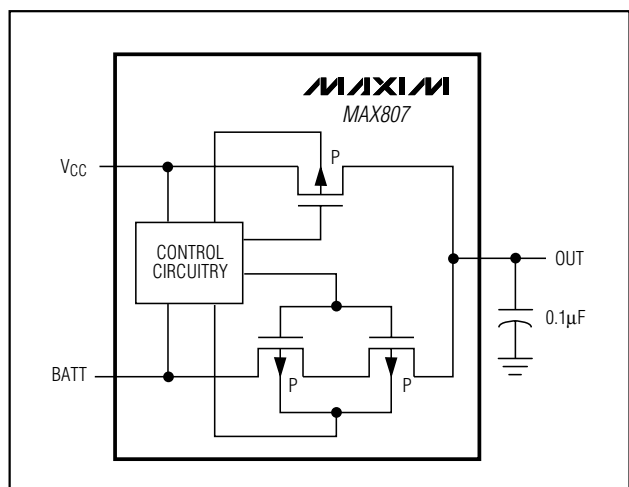

Figure 12.  $V_{CC}$  and BATT-to-OUT Switch

### Battery-Backup Mode

Battery backup preserves the contents of RAM in the event of a brownout or power failure. With a backup battery installed at BATT, the MAX807 automatically switches RAM to backup power when  $V_{CC}$  falls. Two conditions are required for switchover to battery-backup mode: 1)  $V_{CC}$  must be below the reset threshold; 2)  $V_{CC}$  must be below  $V_{BATT}$ . Table 1 lists the status of inputs and outputs during battery-backup mode.

### Backup-Battery Input

The BATT input is similar to  $V_{CC}$ , except the PMOS switch is much smaller. This input is designed to conduct up to 20mA to OUT during battery backup. The on-resistance of the PMOS switch is approximately 13 $\Omega$ . Figure 12 shows the two series pass elements between the BATT input and OUT that facilitate UL approval.  $V_{BATT}$  can exceed  $V_{CC}$  during normal operation without causing a reset.

### Output Supply Voltage

The output supply (OUT) transfers power from  $V_{CC}$  or BATT to the  $\mu$ P, RAM, and other external circuitry. At the maximum source current of 250mA,  $V_{OUT}$  will typically be 260mV below  $V_{CC}$ . Decouple this terminal with a 0.1 $\mu$ F capacitor.

### BATT ON Output

The battery on (BATT ON) output indicates the status of the internal battery switchover comparator, which controls the internal  $V_{CC}$  and BATT switches. For  $V_{CC}$  greater than  $V_{BATT}$  (ignoring the small hysteresis effect), BATT ON typically sinks 3.2mA at 0.4V. In battery-backup mode, this output sources approximately 5mA. Use BATT ON to indicate battery switchover status, or to supply gate or base drive for an external pass transistor for higher current applications (see the *Typical Operating Circuit*).

# Full-Featured $\mu$ P Supervisory Circuit with $\pm 1.5\%$ Reset Accuracy

## BATT OK Output

The BATT OK comparator monitors the backup battery voltage, comparing it with a 2.265V reference ( $V_{CC} \geq 4V$ ). BATT OK remains high as long as the backup battery voltage remains above 2.265V, signaling that the backup battery has sufficient voltage to maintain the memory of static RAM. When the battery voltage drops below 2.265V, the BATT OK output drops low, signaling that the backup battery needs to be changed.

## Applications Information

The MAX807 is not short-circuit protected. Shorting OUT to ground, other than power-up transients such as charging a decoupling capacitor, may destroy the device. If long leads connect to the IC's inputs, ensure that these lines are free from ringing and other conditions that would forward bias the IC's protection diodes.

There are two distinct modes of operation:

- 1) Normal Operating Mode, with all circuitry powered up. Typical supply current from  $V_{CC}$  is  $70\mu A$ , while only leakage currents flow from the battery.
- 2) Battery-Backup Mode, where  $V_{CC}$  is below  $V_{BATT}$  and  $V_{RST}$ . The supply current from the battery is typically less than  $1\mu A$ .

## Using SuperCaps or MaxCaps with the MAX807

BATT has the same operating voltage range as  $V_{CC}$ , and the battery-switchover threshold voltage is typically  $V_{BATT}$  when  $V_{CC}$  is decreasing or  $V_{BATT} + 0.06V$  when  $V_{CC}$  is increasing. This hysteresis allows use of a

SuperCap (e.g., order of 0.47F) and a simple charging circuit as a backup source (Figure 13). Since  $V_{BATT}$  can exceed  $V_{CC}$  while  $V_{CC}$  is above the reset threshold, there are no special precautions when using these  $\mu$ P supervisors with a SuperCap.

## Alternative Chip-Enable Gating

Using memory devices with CE and  $\overline{CE}$  inputs allows the MAX807 CE loop to be bypassed. To do this, connect CE IN to ground, pull up CE OUT to OUT, and connect CE OUT to the CE input of each memory device (Figure 14). The CE input of each part then connects directly to the chip-select logic, which does not have to be gated by the MAX807.

## Adding Hysteresis to the Power-Fail Comparator

The power-fail comparator has a typical input hysteresis of 20mV. This is sufficient for most applications where a power-supply line is being monitored through an external voltage-divider (Figure 10).

Figure 15 shows how to add hysteresis to the power-fail comparator. Select the ratio of R1 and R2 such that PFI sees 2.265V when  $V_{IN}$  falls to the desired trip point ( $V_{TRIP}$ ). Resistor R3 adds hysteresis. It will typically be an order of magnitude greater than R1 or R2. The current through R1 and R2 should be at least  $1\mu A$  to ensure that the 25nA (max) PFI input current does not shift the trip point. R3 should be larger than  $10k\Omega$  to prevent it from loading down the PFO pin. Capacitor C1 adds additional noise rejection.

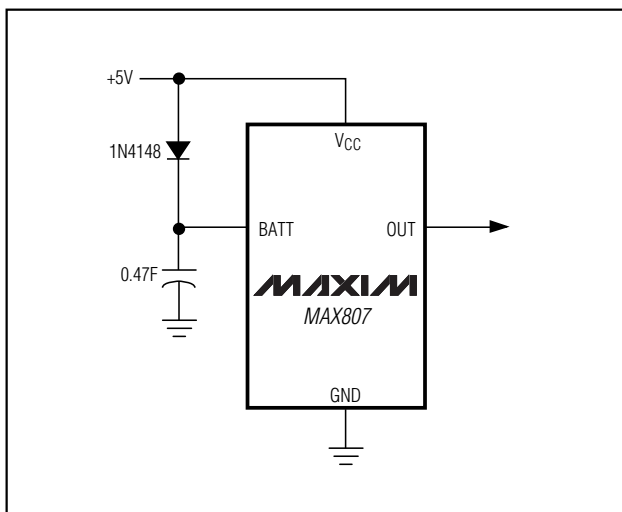

Figure 13. SuperCap or MaxCap on BATT

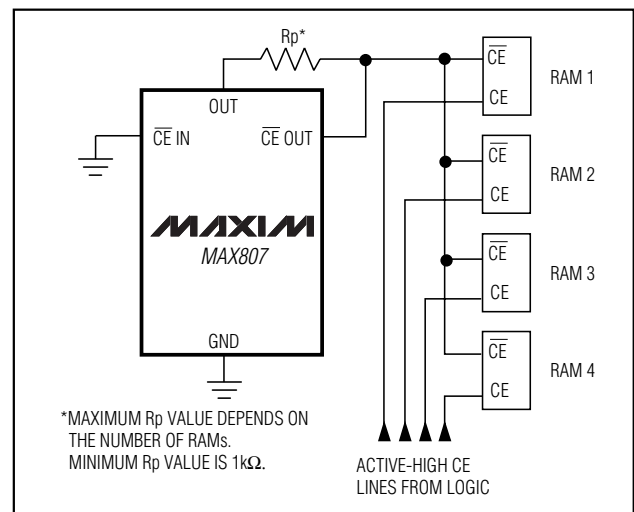

Figure 14. Alternate CE Gating

## Full-Featured $\mu$ P Supervisory Circuit with $\pm 1.5\%$ Reset Accuracy

### Backup-Battery Replacement

The backup battery may be disconnected while VCC is above the reset threshold, provided BATT is bypassed with a 0.1 $\mu$ F capacitor to ground. No precautions are necessary to avoid spurious reset pulses.

### Negative-Going Vcc Transients

While issuing resets to the  $\mu$ P during power-up, power-down, and brownout conditions, these supervisors are relatively immune to short-duration negative-going VCC transients (glitches). It is usually undesirable to reset the  $\mu$ P when VCC experiences only small glitches.

The *Typical Operating Characteristics* show Maximum Transient Duration vs. Reset Comparator Overdrive, for which reset pulses are not generated. The graph was produced using negative-going VCC pulses, starting at 5V and ending below the reset threshold by the magnitude indicated (reset comparator overdrive). The graph shows the maximum pulse width that a negative-going VCC transient may typically have without causing a reset pulse to be issued. As the amplitude of the transient increases (i.e., goes farther below the reset threshold), the maximum allowable pulse width decreases.

Typically, a VCC transient that goes 40mV below the reset threshold and lasts for 3 $\mu$ s or less will not cause a reset pulse to be issued.

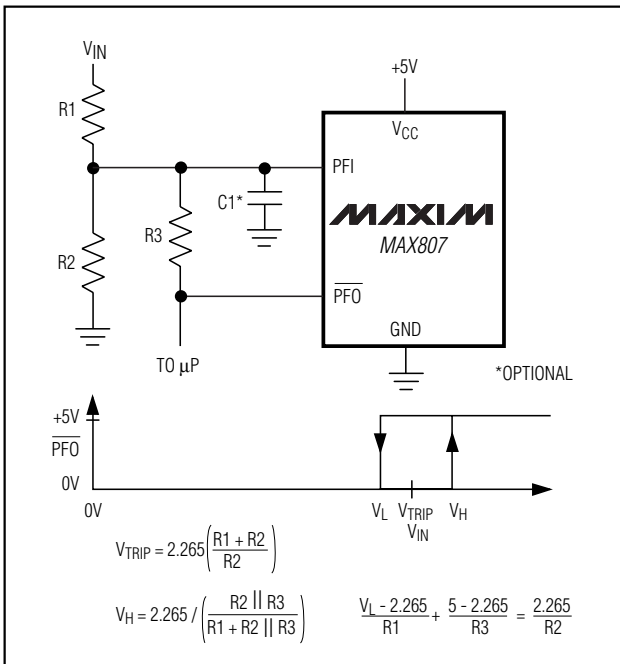

Figure 15. Adding Hysteresis to the Power-Fail Comparator

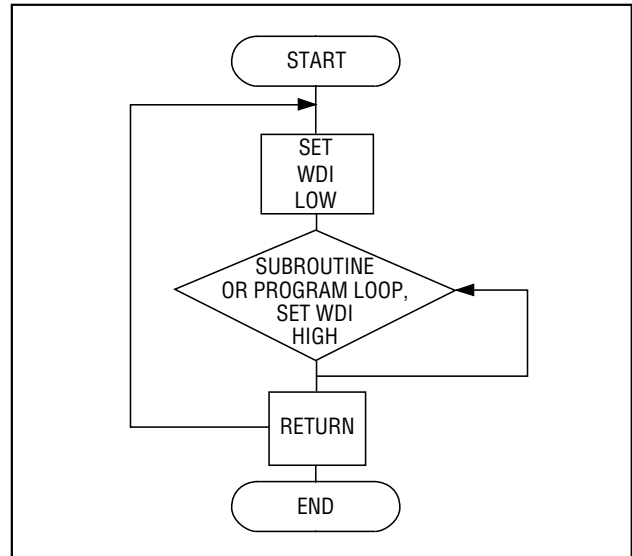

Figure 16. Watchdog Flow Diagram

A 0.1 $\mu$ F bypass capacitor mounted close to the VCC pin provides additional transient immunity.

### Watchdog Software Considerations

To help the watchdog timer keep a closer watch on software execution, you can use the method of setting and resetting the watchdog input at different points in the program, rather than “pulsing” the watchdog input high-low-high or low-high-low. This technique avoids a “stuck” loop where the watchdog timer continues to be reset within the loop, keeping the watchdog from timing out.

Figure 16 shows an example flow diagram where the I/O driving the watchdog input is set high at the beginning of the program, set low at the beginning of every subroutine or loop, then set high again when the program returns to the beginning. If the program should “hang” in any subroutine, the I/O is continually set low and the watchdog timer is allowed to time out, causing a reset or interrupt to be issued.

### Maximum Vcc Fall Time

The VCC fall time is limited by the propagation delay of the battery switchover comparator and should not exceed 0.03V/ $\mu$ s. A standard rule for filter capacitance on most regulators is on the order of 100 $\mu$ F per amp of current. When the power supply is shut off or the main battery is disconnected, the associated initial VCC fall rate is just the inverse or 1A / 100 $\mu$ F = 0.01V/ $\mu$ s. The VCC fall rate decreases with time as VCC falls exponentially, which more than satisfies the maximum fall-time requirement.

**MAX807L/M/N**

# Full-Featured $\mu$ P Supervisory Circuit with $\pm 1.5\%$ Reset Accuracy

## Typical Operating Circuit

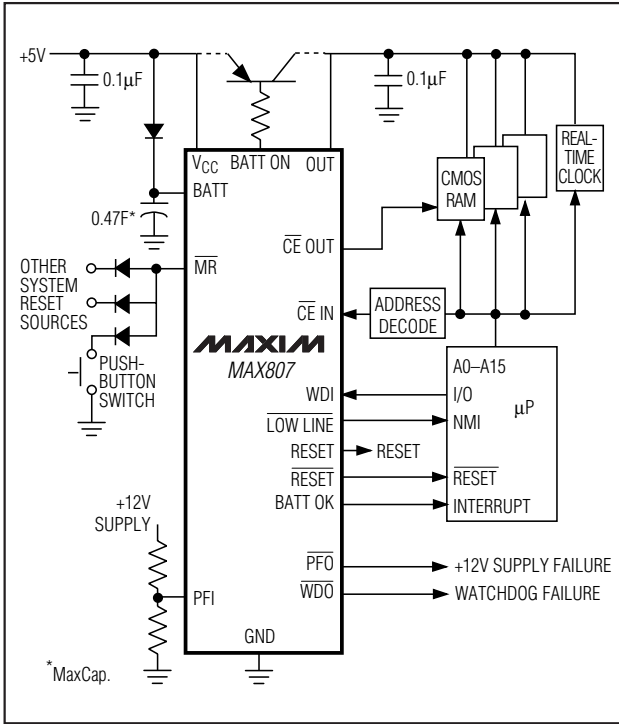

## Ordering Information

PART <sup>†</sup>	TEMP RANGE	PIN-PACKAGE
MAX807_CPE	0°C to +70°C	16 Plastic DIP
MAX807_CUE	0°C to +70°C	16 TSSOP
MAX807_CWE	0°C to +70°C	16 Wide SO
MAX807_EPE	-40°C to +85°C	16 Plastic DIP
MAX807_EUE	-40°C to +85°C	16 TSSOP
MAX807_EWE	-40°C to +85°C	16 Wide SO
MAX807_MJE	-55°C to +125°C	16 CERDIP

<sup>†</sup> This part offers a choice of reset threshold voltage. From the table below, select the suffix corresponding to the desired threshold and insert it into the blank to complete the part number.

Devices in PDIP, SO and TSSOP packages are available in both leaded and lead-free packaging. Specify lead free by adding the + symbol at the end of the part number when ordering. Lead free not available for CERDIP package.

SUFFIX	RESET THRESHOLD (V)		
	MIN	TYP	MAX
L	4.60	4.675	4.75
N	4.50	4.575	4.65
M	4.35	4.425	4.50

## Chip Information

TRANSISTOR COUNT: 984

Maxim cannot assume responsibility for use of any circuitry other than circuitry entirely embodied in a Maxim product. No circuit patent licenses are implied. Maxim reserves the right to change the circuitry and specifications without notice at any time.

16 Maxim Integrated Products, 120 San Gabriel Drive, Sunnyvale, CA 94086 (408) 737-7600