

Excellent Integrated System Limited

Stocking Distributor

Click to view price, real time Inventory, Delivery & Lifecycle Information:

[Maxim Integrated](#)
[MAX798ESE+](#)

For any questions, you can email us directly:

sales@integrated-circuit.com

19-1175; Rev 0; 12/96



High-Accuracy Step-Down Controller with Synchronous Rectifier for CPU Power

General Description

The MAX798 high-performance, step-down DC-DC converter provides main CPU power in battery-powered systems. This buck controller achieves 96% efficiency by using synchronous rectification and Maxim's proprietary Idle Mode™ control scheme to extend battery life at full-load (up to 10A) and no-load outputs. The MAX798's high accuracy meets the demanding requirements of the latest-generation CPUs. Excellent dynamic response corrects output transients caused by the latest dynamic-clock CPUs within five 300kHz clock cycles. Unique bootstrap circuitry drives inexpensive N-channel MOSFETs, reducing system cost and eliminating the crow-bar switching currents found in some PMOS/NMOS switch designs.

The MAX798 has a logic-controlled and synchronizable fixed-frequency pulse-width-modulating (PWM) operating mode, which reduces noise and RF interference in sensitive mobile-communications and pen-entry applications. The $\overline{\text{SKIP}}$ override input allows automatic switchover to idle-mode operation (for high-efficiency pulse skipping) at light loads, or forces fixed-frequency mode for lowest noise at all loads.

Applications

- Notebook and Subnotebook Computers
- PDA's and Mobile Communicators

Pin Configuration

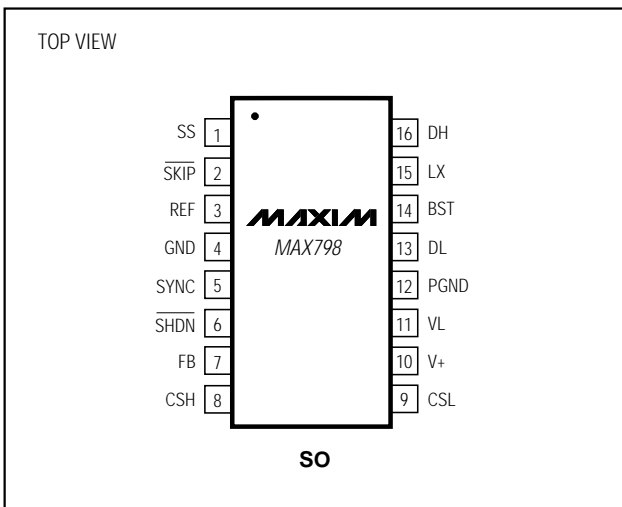

Idle Mode is a trademark of Maxim Integrated Products.

Features

- ◆ 96% Efficiency
- ◆ 4.5V to 30V Input Range
- ◆ 1.6V to 6V Adjustable Precision Output
- ◆ ±0.4% Max Total Load-Regulation Error
- ◆ 0.06%/V Max Line-Regulation Error
- ◆ 5V Linear-Regulator Output
- ◆ Precision 2.505V Reference Output
- ◆ Automatic Bootstrap Circuit
- ◆ 150kHz/300kHz Fixed-Frequency PWM Operation
- ◆ Programmable Soft-Start
- ◆ 1.2mA Typical Quiescent Current ($V_{IN} = 12V, V_{OUT} = 2.5V$)
- ◆ 1µA Typical Shutdown Current

Ordering Information

PART	TEMP. RANGE	PIN-PACKAGE
MAX798ESE	-40°C to +85°C	16 Narrow SO

Typical Operating Circuit

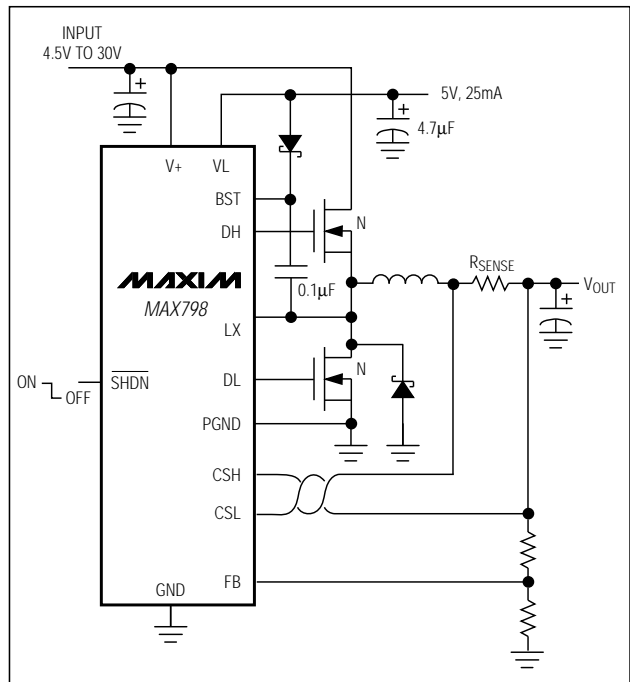

High-Accuracy Step-Down Controller with Synchronous Rectifier for CPU Power

MAX798

ABSOLUTE MAXIMUM RATINGS

V+ to GND	-0.3V, +36V	REF Short Circuit to GND	Continuous
GND to PGND	±2V	VL Output Current	50mA
VL to GND	-0.3V, +7V	Continuous Power Dissipation (T _A = +70°C)	
BST to GND	-0.3V, +36V	SO (derate 8.70mW/°C above +70°C)	696mW
DH to LX	-0.3V, (BST + 0.3V)	Operating Temperature Range	
LX to BST	-7V, +0.3V	MAX798ESE	-40°C to +85°C
SHDN to GND	-0.3V, +36V	Storage Temperature Range	-65°C to +160°C
SYNC, SS, REF, SKIP, DL to GND	-0.3V, (VL + 0.3V)	Lead Temperature (soldering, 10sec)	+300°C
CSH, CSL to GND	-0.3V, +7V		
VL Short Circuit to GND	Momentary		

Stresses beyond those listed under "Absolute Maximum Ratings" may cause permanent damage to the device. These are stress ratings only, and functional operation of the device at these or any other conditions beyond those indicated in the operational sections of the specifications is not implied. Exposure to absolute maximum rating conditions for extended periods may affect device reliability.

ELECTRICAL CHARACTERISTICS

(V+ = +15V, GND = PGND = 0V, I_{VL} = I_{REF} = 0A, T_A = 0°C to +85°C, unless otherwise noted.)

PARAMETER	CONDITIONS	MIN	TYP	MAX	UNITS
STEP-DOWN CONTROLLER					
Input Supply Range		4.5		30	V
Nominal Adjustable Output Voltage Range	External resistor divider	1.6		6	V
Feedback Voltage	CSH - CSL = 40mV, SKIP = VL	1.576	1.6	1.624	V
Load Regulation	0mV < (CSH - CSL) < 80mV, SKIP = VL			±0.4	%
Line Regulation	6V < V+ < 30V		0.04	0.05	%/V
Current-Limit Voltage	CSH - CSL, positive	80	100	120	mV
	CSH - CSL, negative	-40	-100	-160	
SS Source Current		2.0	4.0	6.5	µA
SS Fault Sink Current		2.0			mA
INTERNAL REGULATOR AND REFERENCE					
VL Output Voltage	SHDN = 2V, 0mA < I _{VL} < 25mA, 5.5V < V+ < 30V	4.75		5.25	V
VL Fault Lockout Voltage	Rising edge, hysteresis = 15mV	3.8		4.0	V
VL/CSL Switchover Voltage	Rising edge, hysteresis = 25mV	4.2		4.7	V
Reference Output Voltage	No external load (Note 1)	2.463	2.505	2.537	V
Reference Fault Lockout Voltage	Falling edge	1.8		2.3	V
Reference Load Regulation	0µA < I _{REF} < 100µA			20	mV
CSL Shutdown Leakage Current	SHDN = 0V, CSL = 6V, V+ = 0V or 30V, VL = 0V		0.1	1	µA
V+ Shutdown Current	SHDN = 0V, V+ = 30V, CSL = 0V or 6V		1	5	µA
V+ Off-State Leakage Current	FB = CSH = CSL = 6V, VL switched over to CSL		1	5	µA
Dropout Power Consumption	V+ = 4V, CSL = 0V (Note 2)		6.6	10.5	mW
Quiescent Power Consumption	CSH = CSL = 6V		6.4	8.5	mW

High-Accuracy Step-Down Controller with Synchronous Rectifier for CPU Power

ELECTRICAL CHARACTERISTICS (continued)

(V+ = +15V, GND = PGND = 0V, I_{VL} = I_{REF} = 0A, T_A = 0°C to +85°C, unless otherwise noted.)

PARAMETER	CONDITIONS	MIN	TYP	MAX	UNITS
Oscillator Frequency	SYNC = REF	270	300	330	kHz
	SYNC = 0V or 5V	125	150	175	
SYNC High Pulse Width		200			ns
SYNC Low Pulse Width		200			ns
SYNC Rise/Fall Time	Guaranteed by design			200	ns
Oscillator Sync Range		195		340	kHz
Maximum Duty Cycle	SYNC = REF	89	91		%
	SYNC = 0V or 5V	93	96		
Input High Voltage	SYNC	VL - 0.5			V
	$\overline{\text{SHDN}}$, $\overline{\text{SKIP}}$	2.0			
Input Low Voltage	SYNC	0.8			V
	$\overline{\text{SHDN}}$, $\overline{\text{SKIP}}$	0.5			
Input Current	$\overline{\text{SHDN}}$, 0V or 30V	2			μA
	SYNC, $\overline{\text{SKIP}}$	1			
	CSH, CSL, CSH = CSL = 4V, device not shut down	50			
	FB, FB = 1.6V	±100			nA
DL Sink/Source Current	DL forced to 2V		1		A
DH Sink/Source Current	DH forced to 2V, BST - LX = 4.5V		1		A
DL On-Resistance	High or low			7	Ω
DH On-Resistance	High or low, BST - LX = 4.5V			7	Ω

MAX798

High-Accuracy Step-Down Controller with Synchronous Rectifier for CPU Power

MAX798

ELECTRICAL CHARACTERISTICS

(V+ = +15V, GND = PGND = 0V, I_{VL} = I_{REF} = 0A, T_A = -40°C to +85°C, unless otherwise noted.) (Note 3)

PARAMETER	CONDITIONS	MIN	TYP	MAX	UNITS
STEP-DOWN CONTROLLER					
Input Supply Range		5.0		30	V
Nominal Adjustable Output Voltage Range	External resistor divider	1.6		6.0	V
Feedback Voltage	CSH - CSL = 40mV, $\overline{\text{SKIP}} = \text{VL}$	1.560	1.6	1.640	V
Load Regulation	0mV < (CSH - CSL) < 80mV, $\overline{\text{SKIP}} = \text{VL}$			±1	%
Line Regulation	6V < V+ < 30V		0.04	0.06	%/V
Current-Limit Voltage	CSH - CSL, positive	70		130	mV
	CSH - CSL, negative	-40	-100	-160	
INTERNAL REGULATOR AND REFERENCE					
VL Output Voltage	$\overline{\text{SHDN}} = 2\text{V}$, 0mA < I _{VL} < 25mA, 5.5V < V+ < 30V	4.7		5.3	V
VL Fault Lockout Voltage	Rising edge, hysteresis = 15mV	3.75		4.05	V
VL/CSL Switchover Voltage	Rising edge, hysteresis = 25mV	4.15		4.75	V
Reference Output Voltage	No external load (Note 1)	2.438	2.505	2.562	V
Reference Load Regulation	0μA < I _{REF} < 100μA			30	mV
V+ Shutdown Current	$\overline{\text{SHDN}} = 0\text{V}$, V+ = 30V, CSL = 0V or 6V		1	10	μA
V+ Off-State Leakage Current	FB = CSH = CSL = 6V, VL switched over to CSL		1	10	μA
Quiescent Power Consumption	CSH = CSL = 6V		6.4	9.1	mW
OSCILLATOR AND INPUTS/OUTPUTS					
Oscillator Frequency	SYNC = REF	250	300	350	kHz
	SYNC = 0V or 5V	110	150	190	
SYNC High Pulse Width		250			ns
SYNC Low Pulse Width		250			ns
Oscillator Sync Range		210		320	kHz
Maximum Duty Cycle	SYNC = REF	88	91		%
	SYNC = 0V or 5V	92	96		
DL On-Resistance	High or low			7	Ω
DH On-Resistance	High or low, BST - LX = 4.5V			7	Ω

Note 1: Since the reference uses VL as its supply, V+ line-regulation error is insignificant.

Note 2: At very low input voltages, quiescent supply current can increase due to excess PNP base current in the VL linear regulator. This occurs only if V+ falls below the preset VL regulation point (5V nominal). The typical maximum quiescent current in dropout will not exceed 16mA.

Note 3: All -40°C to +85°C specifications above are guaranteed by design.

High-Accuracy Step-Down Controller with Synchronous Rectifier for CPU Power

Pin Description

MAX798

PIN	NAME	FUNCTION
1	SS	Soft-Start Timing Capacitor Connection. Ramp time to full current limit is approximately 1ms/nF.
2	SKIP	Disables pulse-skipping mode when high. Connect to GND for normal use. Don't leave SKIP unconnected. With SKIP grounded, the device will <i>automatically</i> change from pulse-skipping operation to full PWM operation when the load current exceeds approximately 30% of maximum.
3	REF	Reference Voltage Output. Bypass to GND with 0.33μF minimum.
4	GND	Low-Noise Analog Ground and Feedback Reference Point
5	SYNC	Oscillator Synchronization and Frequency Select. Tie to GND or VL for 150kHz operation; tie to REF for 300kHz operation. A high-to-low transition begins a new cycle. Drive SYNC with 0V to 5V logic levels (see the <i>Electrical Characteristics</i> table for V _{IH} and V _{IL} specifications). SYNC capture range is 195kHz to 340kHz.
6	SHDN	Shutdown Control Input, active low. Logic threshold is set at approximately 1V (V _{TH} of an internal N-channel MOSFET). Tie SHDN to V+ for automatic start-up.
7	FB	Feedback Input. Regulates at FB = 1.6V. Connect FB to a resistor divider to set the output voltage.
8	CSH	Current-Sense Input, high side. Current-limit level is 100mV referred to CSL.
9	CSL	Current-Sense Input, low side
10	V+	Battery Voltage Input (4.5V to 30V). Bypass V+ to PGND close to the IC with a 0.1μF capacitor. Connects to a linear regulator that powers VL.
11	VL	5V Internal Linear-Regulator Output. VL is also the supply voltage rail for the chip. VL is switched to the output voltage via CSL (V _{CSL} > 4.5V) for automatic bootstrapping. Bypass to GND with 4.7μF. VL can supply up to 5mA for external loads.
12	PGND	Power Ground
13	DL	Low-Side Gate-Drive Output. Normally drives the synchronous-rectifier MOSFET. Swings 0V to VL.
14	BST	Boost Capacitor Connection for high-side gate drive (0.1μF)
15	LX	Switching Node (inductor) Connection. Can swing 2V below ground without hazard.
16	DH	High-Side Gate-Drive Output. Normally drives the main buck switch. DH is a floating driver output that swings from LX to BST, riding on the LX switching-node voltage.

High-Accuracy Step-Down Controller with Synchronous Rectifier for CPU Power

MAX798

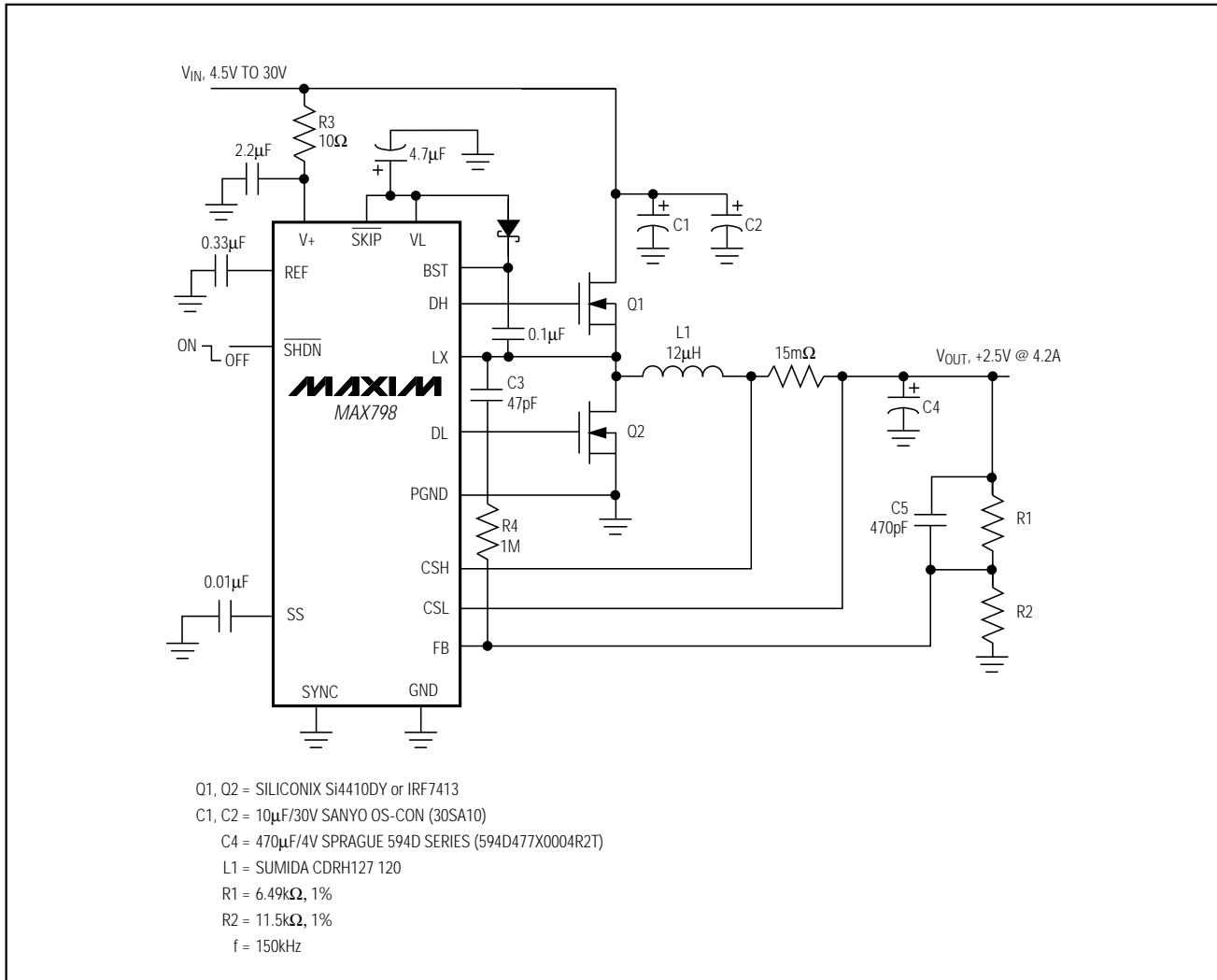

Figure 1. Standard Application Circuit

Detailed Description

The MAX798 is a BiCMOS, switch-mode power-supply controller designed primarily for buck-topology regulators in battery-powered applications where high accuracy, high efficiency, and low quiescent supply current are critical. The MAX798 also works well in other topologies such as boost, inverting, and CUK due to the flexibility of its floating high-speed gate driver. Light-load efficiency is enhanced by automatic idle-mode operation—a variable-frequency pulse-skipping

mode that reduces losses due to MOSFET gate charge. The step-down power-switching circuit consists of two N-channel MOSFETs, a rectifier, and an LC output filter. The output voltage is the average of the AC voltage at the switching node, which is adjusted and regulated by changing the duty cycle of the MOSFET switches. The gate-drive signal to the N-channel high-side MOSFET must exceed the battery voltage and is provided by a flying capacitor boost circuit that uses a 100nF capacitor connected between BST and LX.

High-Accuracy Step-Down Controller with Synchronous Rectifier for CPU Power

MAX798

The MAX798 contains the following seven major circuit blocks, which are shown in Figure 2.

PWM Controller Blocks:

- Multi-Input PWM Comparator
- Current-Sense Circuit
- PWM Logic Block
- Gate-Driver Outputs

Bias Generator Blocks:

- +5V Linear Regulator
- Automatic Bootstrap Switchover Circuit
- +2.505V Reference

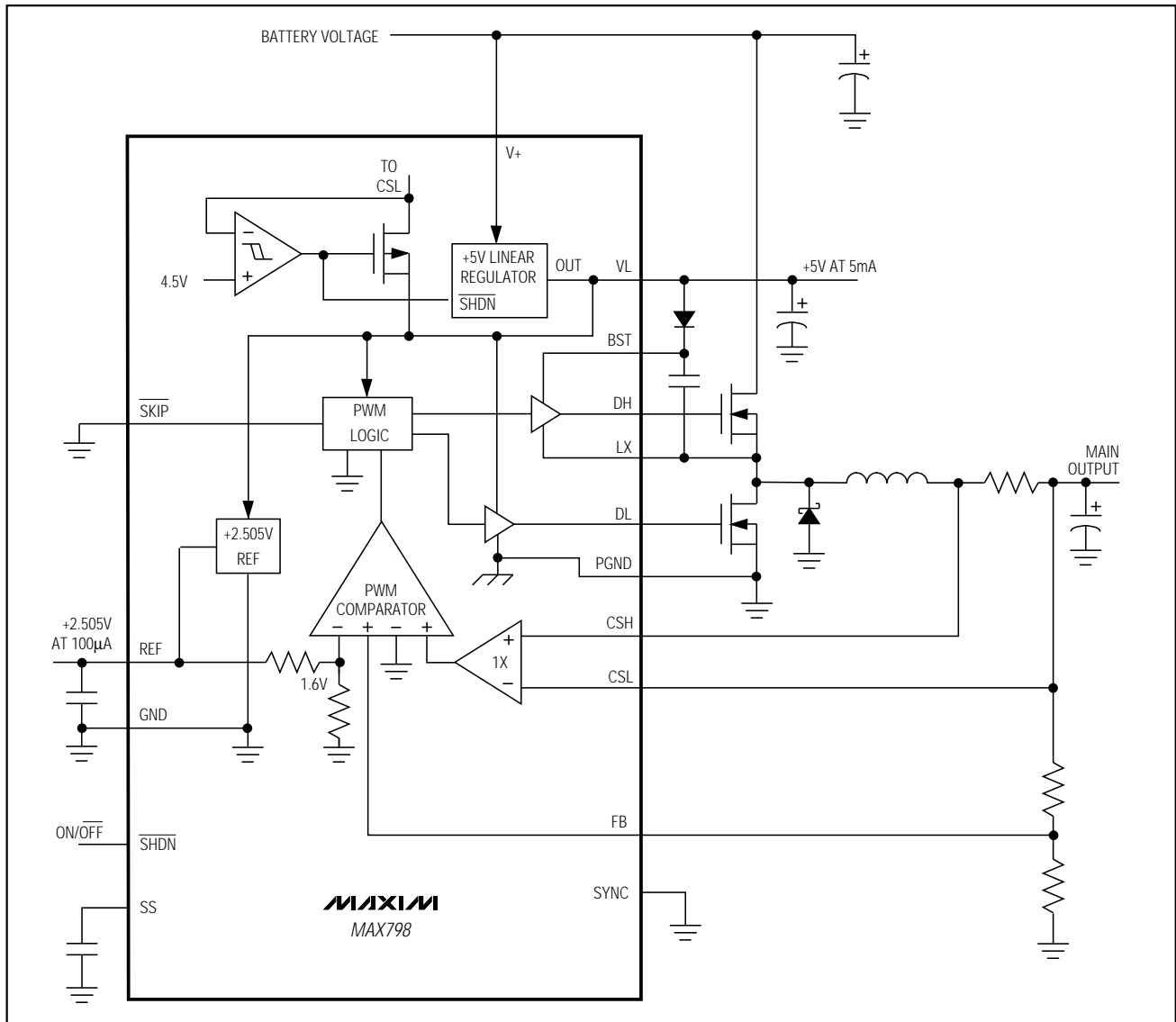

Figure 2. Functional Diagram

High-Accuracy Step-Down Controller with Synchronous Rectifier for CPU Power

These internal IC blocks aren't powered directly from the battery. Instead, a +5V linear regulator steps down the battery voltage to supply both the IC internal rail (VL pin) as well as the gate drivers. The synchronous-switch gate driver is directly powered from +5V VL, while the high-side-switch gate driver is indirectly powered from VL via an external diode-capacitor boost circuit. An automatic bootstrap circuit turns off the +5V linear regulator and powers the IC from its output voltage if the output is above 4.5V.

PWM Controller Block

The heart of the current-mode PWM controller is a multi-input open-loop comparator that sums three signals: output voltage error signal with respect to the reference voltage, current-sense signal, and slope compensation ramp (Figure 3). The PWM controller is a direct summing type, lacking a traditional error amplifier and the phase shift associated with it. This direct-summing configuration approaches the ideal of cycle-by-cycle control over the output voltage.

For more comprehensive information on the MAX798 internal blocks, please refer to the MAX796/MAX797/MAX799 data sheet.

Applications Information

Powering VL from a +5V Supply

If the circuit's output voltage is greater than the VL/CSL switchover voltage, the IC automatically bootstraps and runs off its output. Running from the high-efficiency output rather than the VL linear regulator is particularly desirable if the input voltage is high. If the output is not greater than the VL/CSL switchover threshold, efficiency can be improved by powering VL from another efficient system supply (Figure 4).

VL can be connected directly to a +5V supply, provided its maximum excursions are within a 4.5V to 6V range and the main output voltage's maximum is less than 4.2V. If the circuit's output voltage is greater than 4.2V, the IC can activate its internal bootstrap switch and connect the circuit output to VL.

Adjusting the Output Voltage

The output voltage is set by an external resistor divider between the output voltage and GND, with the midpoint connected to FB (Figure 5). The output voltage can be adjusted from 1.6V to 6V, according to the formula in Figure 5. Recommended R2 values range from 5k Ω to 100k Ω . For best noise immunity, place R1 and R2 close to FB. For a 1.6V output, connect the output voltage directly to FB.

Remote sensing of the output voltage is easily achieved by connecting the top of R1 and, if desired, the bottom of R2, to the remote sense point.

Bypassing and Compensation Components

The MAX798 is designed to deliver a more accurate output voltage than the MAX797. A major source of the MAX797's output error is the decrease in output voltage with increasing load. This error is greatly reduced in the MAX798 by increasing the gain of the voltage-sense signal relative to the current-sense signal. As a result of this increased gain, the MAX798 is slightly more noise sensitive than the MAX797, and requires some small compensation components as well. On the other hand, output capacitor ESR requirements can be greatly relaxed compared to the MAX797, with the limiting factor being the maximum total output voltage ripple that the application can tolerate.

To control noise problems, place the bypass capacitors on REF, VL, and V+ as close as possible to the IC, and use a 10 Ω series resistor (R3, Figure 1) on V+ to form a small lowpass filter. Feed-forward components (R4, C3, and C5) are chosen for stable switching at 150kHz with the components shown. For 300kHz switching and a 4.7 μ H inductor, use R4 = 470k Ω and C5 = 220pF. Keep the components that connect to FB (R4, C5, R1, R2) close to the IC's FB pin.

Design Procedure

With the exception of the items previously mentioned, follow the design procedure for the MAX797. The MAX796/MAX797/MAX799 data sheet contains all necessary information on component values, component selection, layout, and additional applications.

High-Accuracy Step-Down Controller with Synchronous Rectifier for CPU Power

MAX798

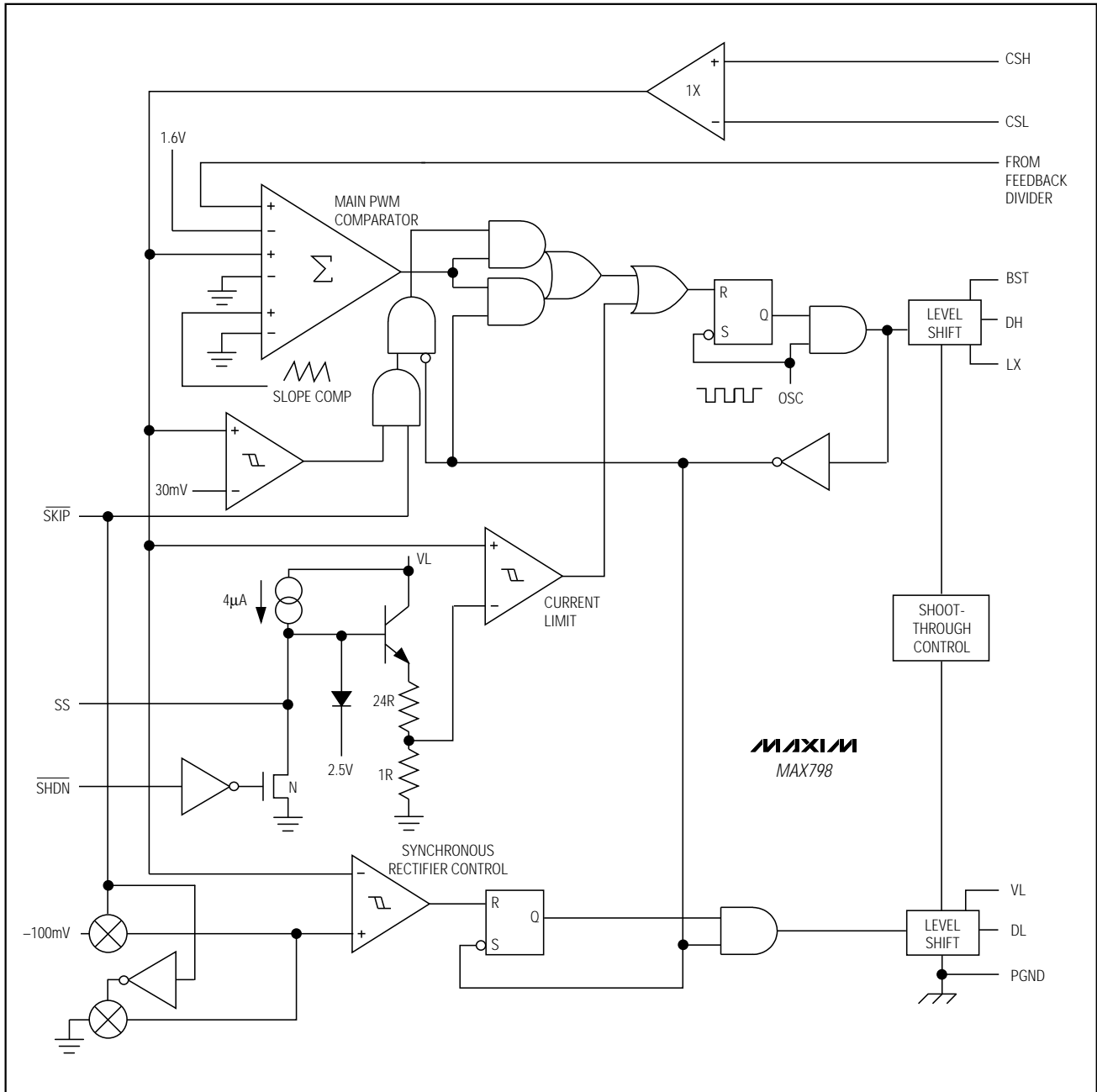

Figure 3. PWM Controller Detailed Block Diagram

MAX798

High-Accuracy Step-Down Controller with Synchronous Rectifier for CPU Power

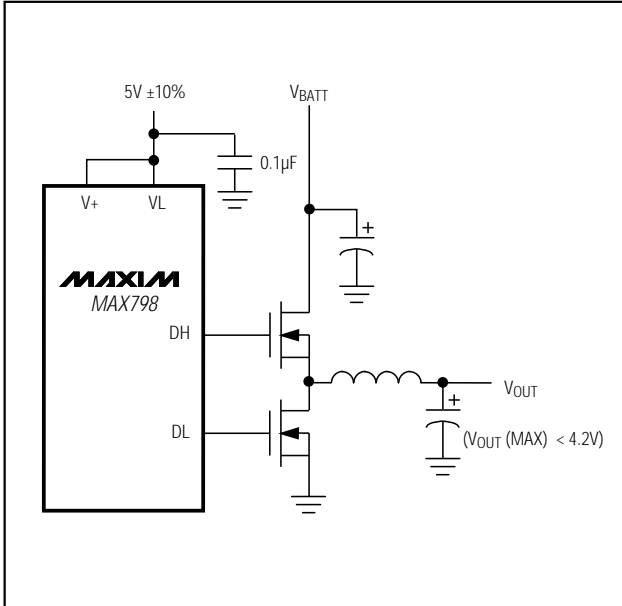

Figure 4. Powering VL from a Separate +5V Supply

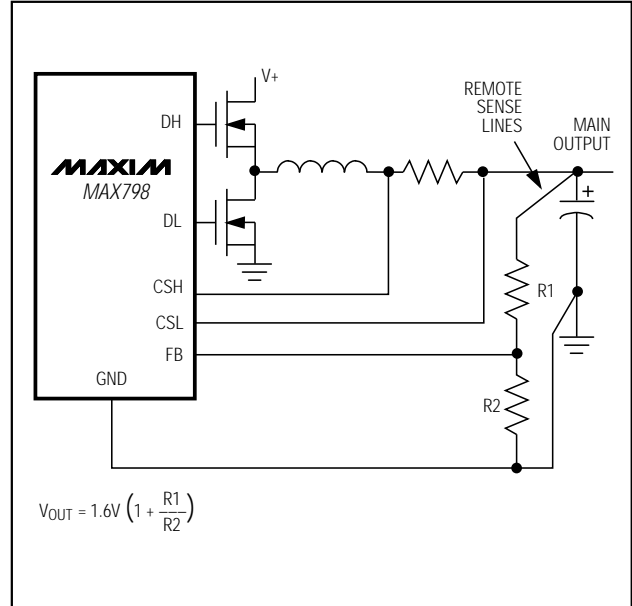

Figure 5. Adjusting the Output Voltage

High-Accuracy Step-Down Controller with Synchronous Rectifier for CPU Power

Chip Information

TRANSISTOR COUNT: 1008

MAX798

Package Information

DIM	INCHES		MILLIMETERS	
	MIN	MAX	MIN	MAX
A	0.053	0.069	1.35	1.75
A1	0.004	0.010	0.10	0.25
B	0.014	0.019	0.35	0.49
C	0.007	0.010	0.19	0.25
E	0.150	0.157	3.80	4.00
e	0.050		1.27	
H	0.228	0.244	5.80	6.20
L	0.016	0.050	0.40	1.27

DIM	PINS	INCHES		MILLIMETERS	
		MIN	MAX	MIN	MAX
D	8	0.189	0.197	4.80	5.00
D	14	0.337	0.344	8.55	8.75
D	16	0.386	0.394	9.80	10.00

21-0041A

**Narrow SO
SMALL-OUTLINE
PACKAGE
(0.150 in.)**

High-Accuracy Step-Down Controller with Synchronous Rectifier for CPU Power

MAX798

NOTES

Maxim cannot assume responsibility for use of any circuitry other than circuitry entirely embodied in a Maxim product. No circuit patent licenses are implied. Maxim reserves the right to change the circuitry and specifications without notice at any time.

12 _____ Maxim Integrated Products, 120 San Gabriel Drive, Sunnyvale, CA 94086 (408) 737-7600