

## Excellent Integrated System Limited

Stocking Distributor

Click to view price, real time Inventory, Delivery & Lifecycle Information:

[Omron](#)  
[G3VM-81GR](#)

For any questions, you can email us directly:  
[sales@integrated-circuit.com](mailto:sales@integrated-circuit.com)

# G3VM-81GR

## MOS FET Relays

### MOS FET Relays Designed for Switching Minute Signals and Analog Signals.

- Turn-ON/turn-OFF times of 0.07 ms (typical).
- Capacity between output terminals of 2.5 pF (typical).

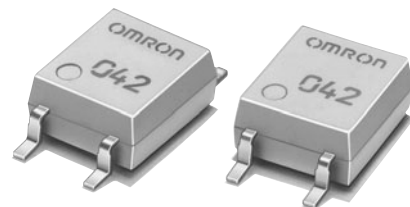

Note: The actual product is marked differently from the image shown here.

RoHS compliant

#### Application Examples

- Semiconductor test equipment
- Test & Measurement equipment
- Communication equipment
- Data loggers

#### Terminal Arrangement/Internal Connections

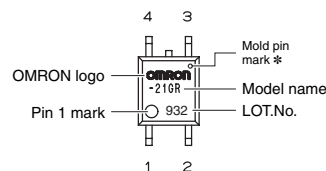
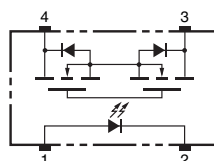

Note: The actual product is marked differently from the image shown here.  
 \* The indentation in the corner diagonally opposite from the pin 1 mark is from a pin on the mold.

#### List of Models

Package type	Contact form	Terminals	Load voltage (peak value) *	Model	Minimum package quantity	
					Number per tube	Number per tape and reel
SOP4	1a (SPST-NO)	Surface-mounting Terminals	80 V	G3VM-81GR	100	-
				G3VM-81GR (TR)	-	2,500

\* The AC peak and DC value are given for the load voltage.

#### Absolute Maximum Ratings (Ta = 25°C)

Item	Symbol	Rating	Unit	Measurement conditions	
Input	LED forward current	IF	50	mA	
	Repetitive peak LED forward current	IFP	1	A	100 μs pulses, 100 pps
	LED forward current reduction rate	ΔIF/°C	-0.5	mA/°C	Ta ≥ 25°C
	LED reverse voltage	VR	5	V	
Output	Connection temperature	TJ	125	°C	
	Load voltage (AC peak/DC)	VOFF	80	V	
	Continuous load current (AC peak/DC)	IO	40	mA	
	ON current reduction rate	ΔIO/°C	-0.4	mA/°C	Ta ≥ 25°C
Dielectric strength between I/O (See note 1.)	VI-O	1500	Vrms	AC for 1 min	
					Connection temperature
Ambient operating temperature	Ta	-20 to +85	°C	With no icing or condensation	
Ambient storage temperature	Tstg	-40 to +125	°C	With no icing or condensation	
Soldering temperature	-	260	°C	10 s	

Note: 1. The dielectric strength between the input and output was checked by applying voltage between all pins as a group on the LED side and all pins as a group on the light-receiving side.

#### Electrical Characteristics (Ta = 25°C)

Item	Symbol	Minimum	Typical	Maximum	Unit	Measurement conditions	
Input	LED forward voltage	VF	1.0	1.15	1.3	V	IF = 10 mA
	Reverse current	IR	-	-	10	μA	VR = 5 V
	Capacity between terminals	CT	-	15	-	pF	V = 0, f = 1 MHz
	Trigger LED forward current	IFT	-	-	3	mA	IO = 40 mA
Output	Maximum resistance with output ON	RON	-	16	25	Ω	IF = 5 mA, IO = 40 mA
	Current leakage when the relay is open	ILEAK	-	-	1	nA	VOFF = 80 V, Ta = 60 °C
	Capacity between terminals	COFF	-	2.5	3.5	pF	V = 0, f = 100 MHz, t < 10 s
	Capacity between I/O terminals	CI-O	-	0.7	-	pF	f = 1 MHz, VS = 0 V
Insulation resistance between I/O terminals	RI-O	1000	-	-	MΩ	VI-O = 500 VDC, RoH ≤ 60 %	
Turn-ON time	tON	-	0.07	0.5	ms	IF = 5 mA, RL = 200 Ω, VDD = 10 V (See note 2.)	
Turn-OFF time	tOFF	-	0.07	0.5	ms		

Note: 2. Turn-ON and Turn-OFF Times

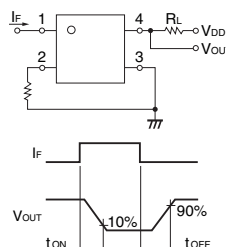

# G3VM-81GR

## MOS FET Relays

### Recommended Operating Conditions

Use the G3VM under the following conditions so that the Relay will operate properly.

Item	Symbol	Minimum	Typical	Maximum	Unit
Load voltage (AC peak/DC)	V <sub>DD</sub>	-	-	64	V
Operating LED forward current	I <sub>F</sub>	5	-	30	mA
Continuous load current (AC peak/DC)	I <sub>O</sub>	-	-	40	mA
Ambient operating temperature	T <sub>a</sub>	25	-	60	°C

### Engineering Data

LED forward current vs. Ambient temperature

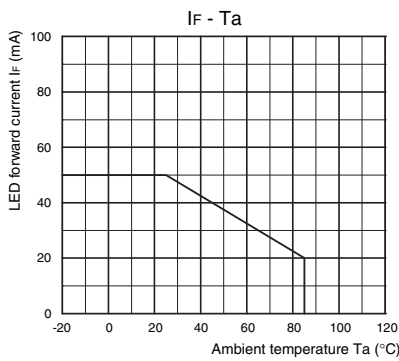

Continuous load current vs. Ambient temperature

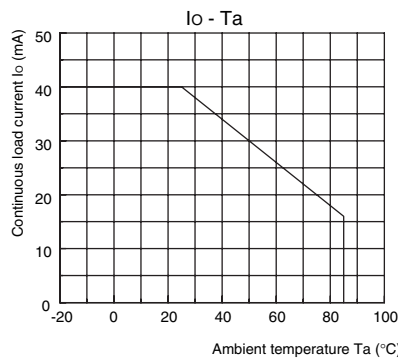

LED forward current vs. LED forward voltage

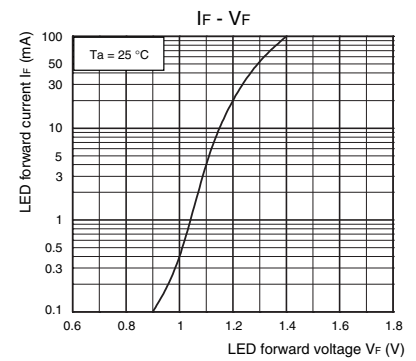

Continuous load current vs. On-state voltage

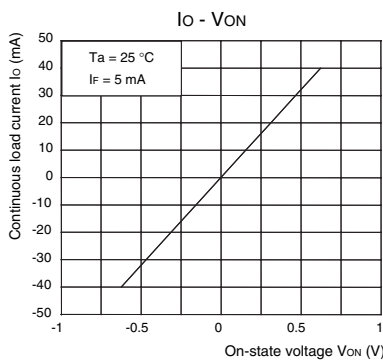

On-state resistance vs. Ambient temperature

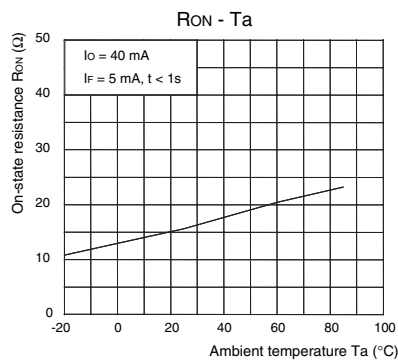

Trigger LED forward current vs. Ambient temperature

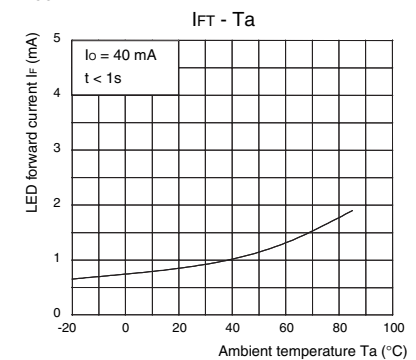

Turn ON, Turn OFF time vs. LED forward current

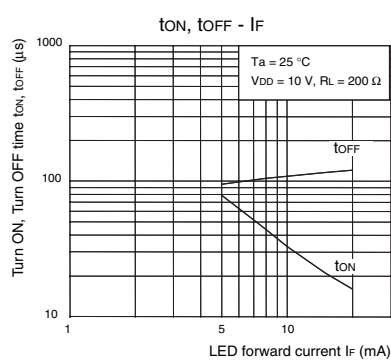

Turn ON, Turn OFF time vs. Ambient temperature

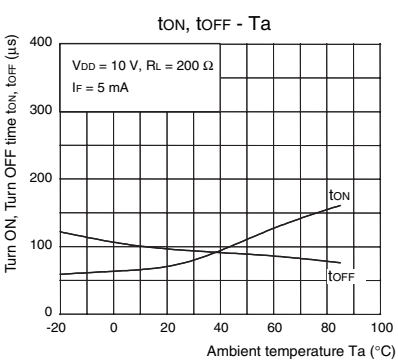

Current leakage vs. Load voltage

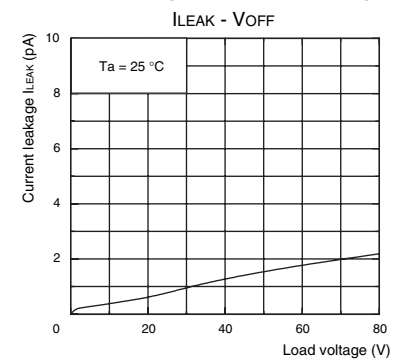

Output terminal capacitance vs. Load voltage

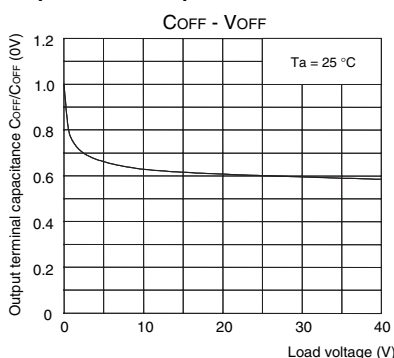

### Safety Precautions

- Refer to "Common Precautions" for all G3VM models.

# Appearance/Dimensions

**SOP4 type**

## ■ Appearance

### SOP (Small Outline Package)

SOP4

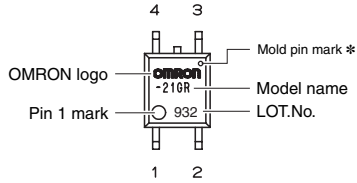

Note: The actual product is marked differently from the image shown here.

\* The indentation in the corner diagonally opposite from the pin 1 mark is from a pin on the mold.

## ■ Dimensions

(Unit: mm)

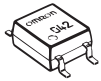

### Surface-mounting Terminals

Weight: 0.1 g

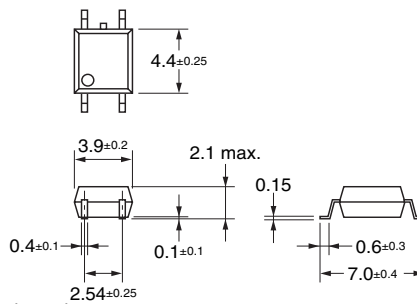

### Actual Mounting Pad Dimensions

(Recommended Value, TOP VIEW)

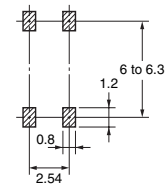

Note: The actual product is marked differently from the image shown here.

- Application examples provided in this document are for reference only. In actual applications, confirm equipment functions and safety before using the product.
- Consult your OMRON representative before using the product under conditions which are not described in the manual or applying the product to nuclear control systems, railroad systems, aviation systems, vehicles, combustion systems, medical equipment, amusement machines, safety equipment, and other systems or equipment that may have a serious influence on lives and property if used improperly. Make sure that the ratings and performance characteristics of the product provide a margin of safety for the system or equipment, and be sure to provide the system or equipment with double safety mechanisms.

Note: Do not use this document to operate the Unit.