

## Excellent Integrated System Limited

Stocking Distributor

Click to view price, real time Inventory, Delivery & Lifecycle Information:

[Linx Technologies](#)  
[CONSMA014-R178](#)

For any questions, you can email us directly:

[sales@integrated-circuit.com](mailto:sales@integrated-circuit.com)

Description	Material	Finish
Body	Brass	Nickel
Socket	BE CU	Gold
Insulation	PTFE	N/A
O Ring	SI Rubber	Rubber
Washer	Brass	Nickel
Nut	Brass	Nickel
Spacer	PTFE	N/A
Support	Brass	Nickel
Heat Shrink	Polyolefin	Black

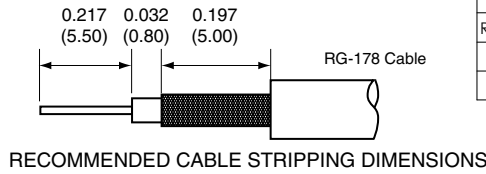

REVISIONS			
REV	DESCRIPTION	DATE	APPV
A	Add heat shrink, new frame, revised stripping instruct./dims	4/21/10	CJ
B	Updated footprint and dimensions; Added new title block	10-JUL-12	BPM

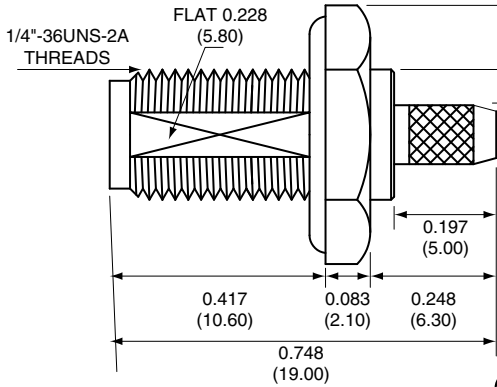

CON SMA014-R178 ASSEMBLY INSTRUCTIONS

- Strip the cable to the recommended dimensions.
- Slide the coax into the support until the outside insulation bottoms out against the inside shoulder of the support.
- Solder the support onto the braid.
- Place the spacer onto the center conductor.
- Solder or crimp the socket onto the center conductor.
- Insert the socket, center conductor, spacer, and support into the body until the top of the socket is even with the white insulation in the body.
- Crimp the tail of the body onto the support with a 0.093" hex crimp tool.

O-RING

0.055 (1.40)

Ø0.236 (6.00)

Ø0.358 (9.10)

0.065 [1.65]

0.234 [6.00]

Ø0.256 [6.50]

0.020 [0.50]

0.020 [0.50]

0.020 [0.50]

0.020 [0.50]

0.020 [0.50]

0.020 [0.50]

0.020 [0.50]

0.020 [0.50]

0.020 [0.50]

0.020 [0.50]

0.020 [0.50]

0.020 [0.50]

0.020 [0.50]

0.020 [0.50]

0.020 [0.50]

0.020 [0.50]

0.020 [0.50]

0.020 [0.50]

0.020 [0.50]

0.020 [0.50]

0.020 [0.50]

0.020 [0.50]

0.020 [0.50]

0.020 [0.50]

0.020 [0.50]

0.020 [0.50]

0.020 [0.50]

0.020 [0.50]

0.020 [0.50]

0.020 [0.50]

0.020 [0.50]

0.020 [0.50]

0.020 [0.50]

0.020 [0.50]

0.020 [0.50]

0.020 [0.50]

0.020 [0.50]

0.020 [0.50]

0.020 [0.50]

0.020 [0.50]

0.020 [0.50]

NOTES: (UNLESS OTHERWISE SPECIFIED)

- ALL DIMENSIONS ARE IN INCHES [mm].
- DIMENSIONS APPLY AFTER FINISHING.
- MANUFACTURE TO BE COMPLIANT WITH EU RoHS DIRECTIVE.
- SAFETY BREAK ALL SHARP CORNERS AND EDGES .02 MAXIMUM.

WARNING: THIS DRAWING CONTAINS PROPRIETARY INFORMATION THAT IS THE SOLE PROPERTY OF LINX TECHNOLOGIES, AND SHALL BE TREATED AS SUCH. NO DISCLOSURE OR REPRODUCTION OF THIS DOCUMENT IS PERMITTED, IN WHOLE OR IN PART, WITHOUT THE EXPRESS WRITTEN PERMISSION OF LINX TECHNOLOGIES OR ITS DESIGNATED AGENTS.

MATERIAL:	TOLERANCES:	PROJECTION:
	.020 [0.50]-.200 [5.00]= ± .008 [0.20]	
	.200 [5.00]-1.200 [30.00]= ± .016 [0.40]	
	1.20 [30.0]-4.75 [120.0]= ± .024 [0.60]	
	4.75 [120.0]-12.40 [315.0]= ± .040 [1.0]	
FINISH:	DRAWN: B.MURPHY DT: 10-JUL-12	ANGLES: ± 1°
	ENGR: S.HOGAN DT: 10-JUL-12	

		159 ORT LANE	
		MERLIN, OR 97532	
TITLE: SMA FEMALE BULKHEAD MOUNT CABLE END CRIMP WITH O-RING FOR RG178 CABLE			
SIZE	DWG. NO.	REV	
A	CON SMA014-R178	B	
SCALE: 2:1	DO NOT SCALE DRAWING	SHEET 1 OF 1	