

## Excellent Integrated System Limited

Stocking Distributor

Click to view price, real time Inventory, Delivery & Lifecycle Information:

[Texas Instruments](#)  
[SN74LS181N](#)

For any questions, you can email us directly:

[sales@integrated-circuit.com](mailto:sales@integrated-circuit.com)

SN54LS181, SN54S181

SN74LS181, SN74S181

**ARITHMETIC LOGIC UNITS/FUNCTION GENERATORS**

SDLS136 - DECEMBER 1972 - REVISED MARCH 1988

- Full Look-Ahead for High-Speed Operations on Long Words
- Input Clamping Diodes Minimize Transmission-Line Effects
- Darlington Outputs Reduce Turn-Off Time
- Arithmetic Operating Modes:
  - Addition
  - Subtraction
  - Shift Operand A One Position
  - Magnitude Comparison
  - Plus Twelve Other Arithmetic Operations
- Logic Function Modes:
  - Exclusive-OR
  - Comparator
  - AND, NAND, OR, NOR
  - Plus Ten Other Logic Operations

SN54LS181, SN54S181 . . . J OR W PACKAGE  
SN74LS181, SN74S181 . . . DW OR N PACKAGE

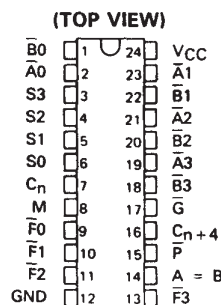

SN54LS181, SN54S181 . . . FK PACKAGE

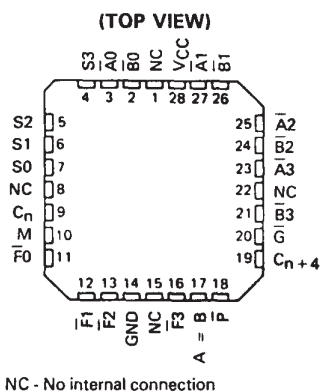

TYPICAL ADDITION TIMES

NUMBER OF BITS	ADDITION TIMES		PACKAGE COUNT		CARRY METHOD BETWEEN ALUs
	USING 'LS181 AND 'S182	USING 'S181 AND 'S182	ARITHMETIC/ LOGIC UNITS	LOOK-AHEAD CARRY GENERATORS	
1 to 4	24 ns	11 ns	1		NONE
5 to 8	40 ns	18 ns	2		RIPPLE
9 to 16	44 ns	19 ns	3 or 4	1	FULL LOOK-AHEAD
17 to 64	68 ns	28 ns	5 to 16	2 to 5	FULL LOOK-AHEAD

**description**

The 'LS181 and 'S181 are arithmetic logic units (ALU)/function generators that have a complexity of 75 equivalent gates on a monolithic chip. These circuits perform 16 binary arithmetic operations on two 4-bit words as shown in Tables 1 and 2. These operations are selected by the four function-select lines (S0, S1, S2, S3) and include addition, subtraction, decrement, and straight transfer. When performing arithmetic manipulations, the internal carries must be enabled by applying a low-level voltage to the mode control input (M). A full carry look-ahead scheme is made available in these devices for fast, simultaneous carry generation by means of two cascade-outputs (pins 15 and 17) for the four bits in the package. When used in conjunction with the SN54S182 or SN74S182 full carry look-ahead circuits, high-speed arithmetic operations can be performed. The typical addition times shown above illustrate the little additional time required for addition of longer words when full carry look-ahead is employed. The method of cascading 'S182 circuits with these ALUs to provide multi-level full carry look-ahead is illustrated under typical applications data for the 'S182.

If high speed is not of importance, a ripple-carry input (C<sub>n</sub>) and a ripple-carry output (C<sub>n+4</sub>) are available. However, the ripple-carry delay has also been minimized so that arithmetic manipulations for small word lengths can be performed without external circuitry.

PRODUCTION DATA information is current as of publication date. Products conform to specifications per the terms of Texas Instruments standard warranty. Production processing does not necessarily include testing of all parameters.

**SN54LS181, SN54S181**  
**SN74LS181, SN74S181**  
**ARITHMETIC LOGIC UNITS/FUNCTION GENERATORS**  
SDLS136 – DECEMBER 1972 – REVISED MARCH 1988

**description (continued)**

The 'LS181 and 'S181 will accommodate active-high data if the pin designations are interpreted as follows:

PIN NUMBER	2	1	23	22	21	20	19	18	9	10	11	13	7	16	15	17
Active-low data (Table 1)	$\bar{A}_0$	$\bar{B}_0$	$\bar{A}_1$	$\bar{B}_1$	$\bar{A}_2$	$\bar{B}_2$	$\bar{A}_3$	$\bar{B}_3$	$\bar{F}_0$	$\bar{F}_1$	$\bar{F}_2$	$\bar{F}_3$	$C_n$	$C_{n+4}$	$\bar{P}$	$\bar{G}$
Active-high data (Table 2)	A <sub>0</sub>	B <sub>0</sub>	A <sub>1</sub>	B <sub>1</sub>	A <sub>2</sub>	B <sub>2</sub>	A <sub>3</sub>	B <sub>3</sub>	F <sub>0</sub>	F <sub>1</sub>	F <sub>2</sub>	F <sub>3</sub>	$\bar{C}_n$	$\bar{C}_{n+4}$	X	Y

Subtraction is accomplished by 1's complement addition where the 1's complement of the subtrahend is generated internally. The resultant output is  $A-B-1$ , which requires an end-around or forced carry to provide  $A-B$ .

The 'LS181 or 'S181 can also be utilized as a comparator. The  $A = B$  output is internally decoded from the function outputs ( $F_0, F_1, F_2, F_3$ ) so that when two words of equal magnitude are applied at the A and B inputs, it will assume a high level to indicate equality ( $A = B$ ). The ALU must be in the subtract mode with  $C_n = H$  when performing this comparison. The  $A = B$  output is open-collector so that it can be wire-AND connected to give a comparison for more than four bits. The carry output ( $C_{n+4}$ ) can also be used to supply relative magnitude information. Again, the ALU must be placed in the subtract mode by placing the function select inputs  $S_3, S_2, S_1, S_0$  at L, H, H, L, respectively.

INPUT $C_n$	OUTPUT $C_{n+4}$	ACTIVE-LOW DATA (FIGURE 1)	ACTIVE-HIGH DATA (FIGURE 2)
H	H	$A \geq B$	$A < B$
H	L	$A < B$	$A > B$
L	H	$A > B$	$A < B$
L	L	$A \leq B$	$A \geq B$

These circuits have been designed to not only incorporate all of the designer's requirements for arithmetic operations, but also to provide 16 possible functions of two Boolean variables without the use of external circuitry. These logic functions are selected by use of the four function-select inputs ( $S_0, S_1, S_2, S_3$ ) with the mode-control input (M) at a high level to disable the internal carry. The 16 logic functions are detailed in Tables 1 and 2 and include exclusive-OR, NAND, AND, NOR, and OR functions.

Series 54, 54LS, and 54S devices are characterized for operation over the full military temperature range of  $-55^\circ\text{C}$  to  $125^\circ\text{C}$ ; Series 74LS and 74S devices are characterized for operation from  $0^\circ\text{C}$  to  $70^\circ\text{C}$ .

**signal designations**

In both Figures 1 and 2, the polarity indicators ( $\nabla$ ) indicate that the associated input or output is active-low with respect to the function shown inside the symbol, and the symbols are the same in both figures. The signal designations in Figure 1 agree with the indicated internal functions based on active-low data, and are for use with the logic functions and arithmetic operations shown in Table 1. The signal designations have been changed in Figure 2 to accommodate the logic functions and arithmetic operations for the active-high data given in Table 2. The 'LS181 and 'S181, together with the 'S182, can be used with the signal designation of either Figure 1 or Figure 2.

SN54LS181, SN54S181  
 SN74LS181, SN74S181  
**ARITHMETIC LOGIC UNITS/FUNCTION GENERATORS**  
 SDLS136 - DECEMBER 1972 - REVISED MARCH 1988

logic symbols<sup>†</sup> and signal designations (active-low data)

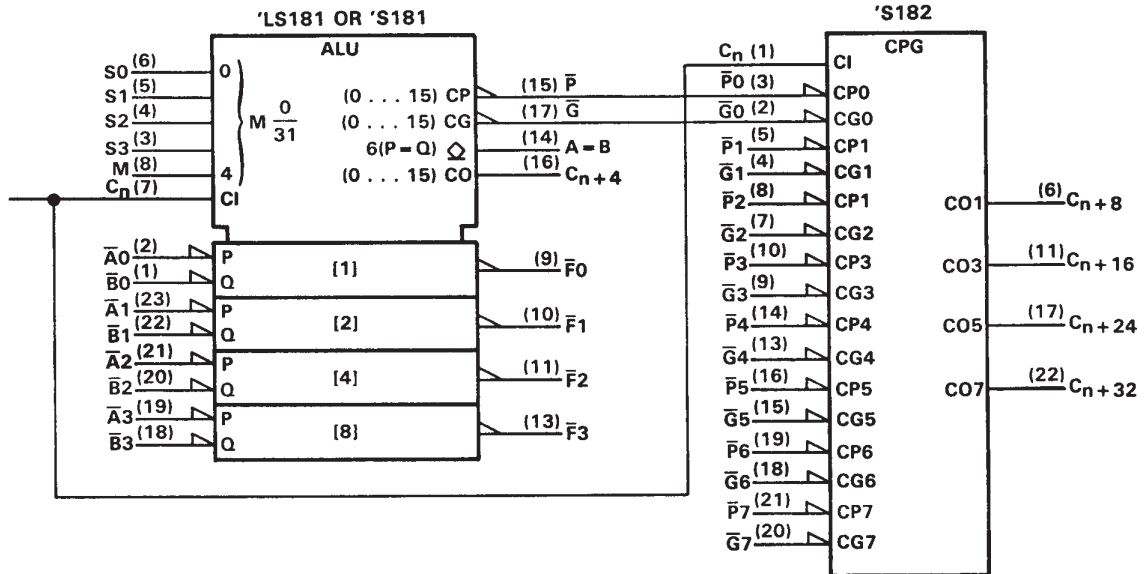

<sup>†</sup>These symbols are in accordance with ANSI/IEEE Std. 91-1984 and IEC Publication 617-12.  
 Pin numbers shown are for dual-in-line and "small outline" packages.

FIGURE 1 (USE WITH TABLE 1)

TABLE 1

SELECTION				ACTIVE-LOW DATA		
				M = H LOGIC FUNCTIONS	M = L; ARITHMETIC OPERATIONS	
S3	S2	S1	S0		Cn = L (no carry)	Cn = H (with carry)
L	L	L	L	$F = \overline{A}$	F = A MINUS 1	F = A
L	L	L	H	$F = \overline{AB}$	F = AB MINUS 1	F = AB
L	L	H	L	$F = \overline{A} + B$	F = $\overline{AB}$ MINUS 1	$F = \overline{AB}$
L	L	H	H	F = 1	F = MINUS 1 (2's COMP)	F = ZERO
L	H	L	L	$F = \overline{A} + B$	$F = A \text{ PLUS } (A + \overline{B})$	$F = A \text{ PLUS } (A + \overline{B}) \text{ PLUS } 1$
L	H	L	H	$F = \overline{B}$	$F = AB \text{ PLUS } (A + \overline{B})$	$F = AB \text{ PLUS } (A + \overline{B}) \text{ PLUS } 1$
L	H	H	L	$F = A \oplus B$	F = A MINUS B MINUS 1	F = A MINUS B
L	H	H	H	$F = A + \overline{B}$	$F = A + \overline{B}$	$F = (A + \overline{B}) \text{ PLUS } 1$
H	L	L	L	$F = \overline{AB}$	$F = A \text{ PLUS } (A + B)$	$F = A \text{ PLUS } (A + B) \text{ PLUS } 1$
H	L	L	H	$F = A \oplus B$	F = A PLUS B	F = A PLUS B PLUS 1
H	L	H	L	F = B	$F = \overline{AB} \text{ PLUS } (A + B)$	$F = \overline{AB} \text{ PLUS } (A + B) \text{ PLUS } 1$
H	L	H	H	$F = A + B$	$F = (A + B)$	$F = (A + B) \text{ PLUS } 1$
H	H	L	L	F = 0	$F = A \text{ PLUS } A^\ddagger$	$F = A \text{ PLUS } A \text{ PLUS } 1$
H	H	L	H	$F = \overline{AB}$	F = AB PLUS A	F = AB PLUS A PLUS 1
H	H	H	L	F = AB	$F = \overline{AB} \text{ PLUS } A$	$F = \overline{AB} \text{ PLUS } A \text{ PLUS } 1$
H	H	H	H	F = A	F = A	F = A PLUS 1

<sup>‡</sup>Each bit is shifted to the next more significant position.

**SN54LS181, SN54S181**  
**SN74LS181, SN74S181**  
**ARITHMETIC LOGIC UNITS/FUNCTION GENERATORS**  
 SDLS136 - DECEMBER 1972 - REVISED MARCH 1988

logic symbols† and signal designations (active-high data)

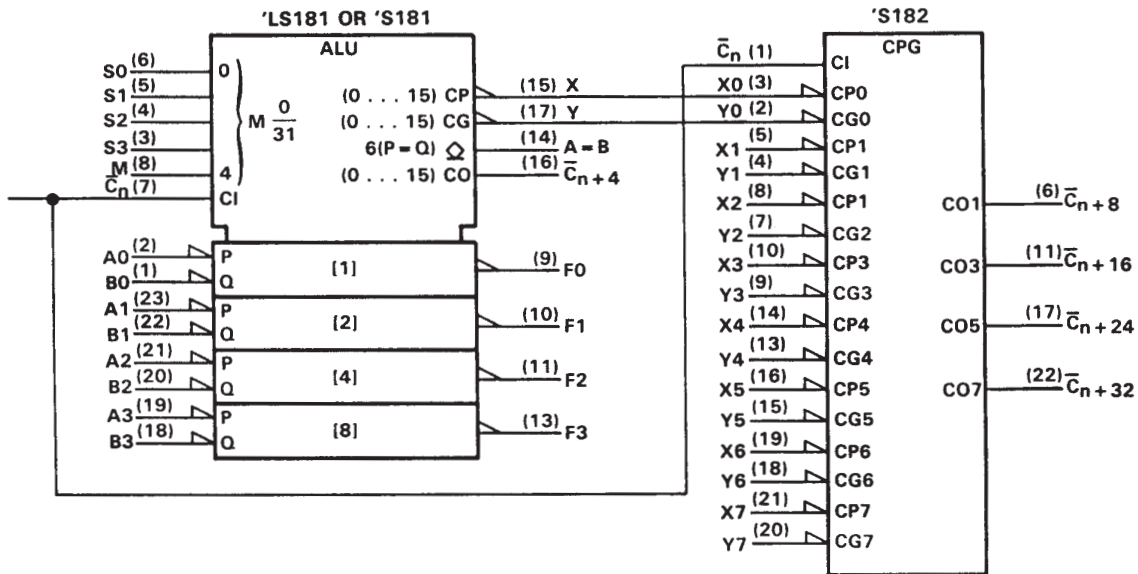

†These symbols are in accordance with ANSI/IEEE Std. 91-1984 and IEC Publication 617-12.  
 Pin numbers shown are for dual-in-line and "small outline" packages.

FIGURE 2 (USE WITH TABLE 2)

TABLE 2

SELECTION				ACTIVE-HIGH DATA		
				M = H LOGIC FUNCTIONS	M = L; ARITHMETIC OPERATIONS	
S3	S2	S1	S0		$\bar{C}_n = H$ (no carry)	$\bar{C}_n = L$ (with carry)
L	L	L	L	$F = \bar{A}$	$F = A$	$F = A \text{ PLUS } 1$
L	L	L	H	$F = A + \bar{B}$	$F = A + B$	$F = (A + B) \text{ PLUS } 1$
L	L	H	L	$F = \bar{A}B$	$F = A + \bar{B}$	$F = (A + \bar{B}) \text{ PLUS } 1$
L	L	H	H	$F = 0$	$F = \text{MINUS } 1 \text{ (2's COMPL)}$	$F = \text{ZERO}$
L	H	L	L	$F = \overline{AB}$	$F = A \text{ PLUS } \overline{AB}$	$F = A \text{ PLUS } \overline{AB} \text{ PLUS } 1$
L	H	L	H	$F = \bar{B}$	$F = (A + B) \text{ PLUS } \overline{AB}$	$F = (A + B) \text{ PLUS } \overline{AB} \text{ PLUS } 1$
L	H	H	L	$F = A \oplus B$	$F = A \text{ MINUS } B \text{ MINUS } 1$	$F = A \text{ MINUS } B$
L	H	H	H	$F = A\bar{B}$	$F = \overline{AB} \text{ MINUS } 1$	$F = \overline{AB}$
H	L	L	L	$F = \overline{A + B}$	$F = A \text{ PLUS } AB$	$F = A \text{ PLUS } AB \text{ PLUS } 1$
H	L	L	H	$F = \overline{A \oplus B}$	$F = A \text{ PLUS } B$	$F = A \text{ PLUS } B \text{ PLUS } 1$
H	L	H	L	$F = B$	$F = (A + \bar{B}) \text{ PLUS } AB$	$F = (A + \bar{B}) \text{ PLUS } AB \text{ PLUS } 1$
H	L	H	H	$F = AB$	$F = AB \text{ MINUS } 1$	$F = AB$
H	H	L	L	$F = 1$	$F = A \text{ PLUS } A^\dagger$	$F = A \text{ PLUS } A \text{ PLUS } 1$
H	H	L	H	$F = A + \bar{B}$	$F = (A + B) \text{ PLUS } A$	$F = (A + B) \text{ PLUS } A \text{ PLUS } 1$
H	H	H	L	$F = A + B$	$F = (A + \bar{B}) \text{ PLUS } A$	$F = (A + \bar{B}) \text{ PLUS } A \text{ PLUS } 1$
H	H	H	H	$F = A$	$F = A \text{ MINUS } 1$	$F = A$

† Each bit is shifted to the next more significant position.

**logic diagram (positive logic)**

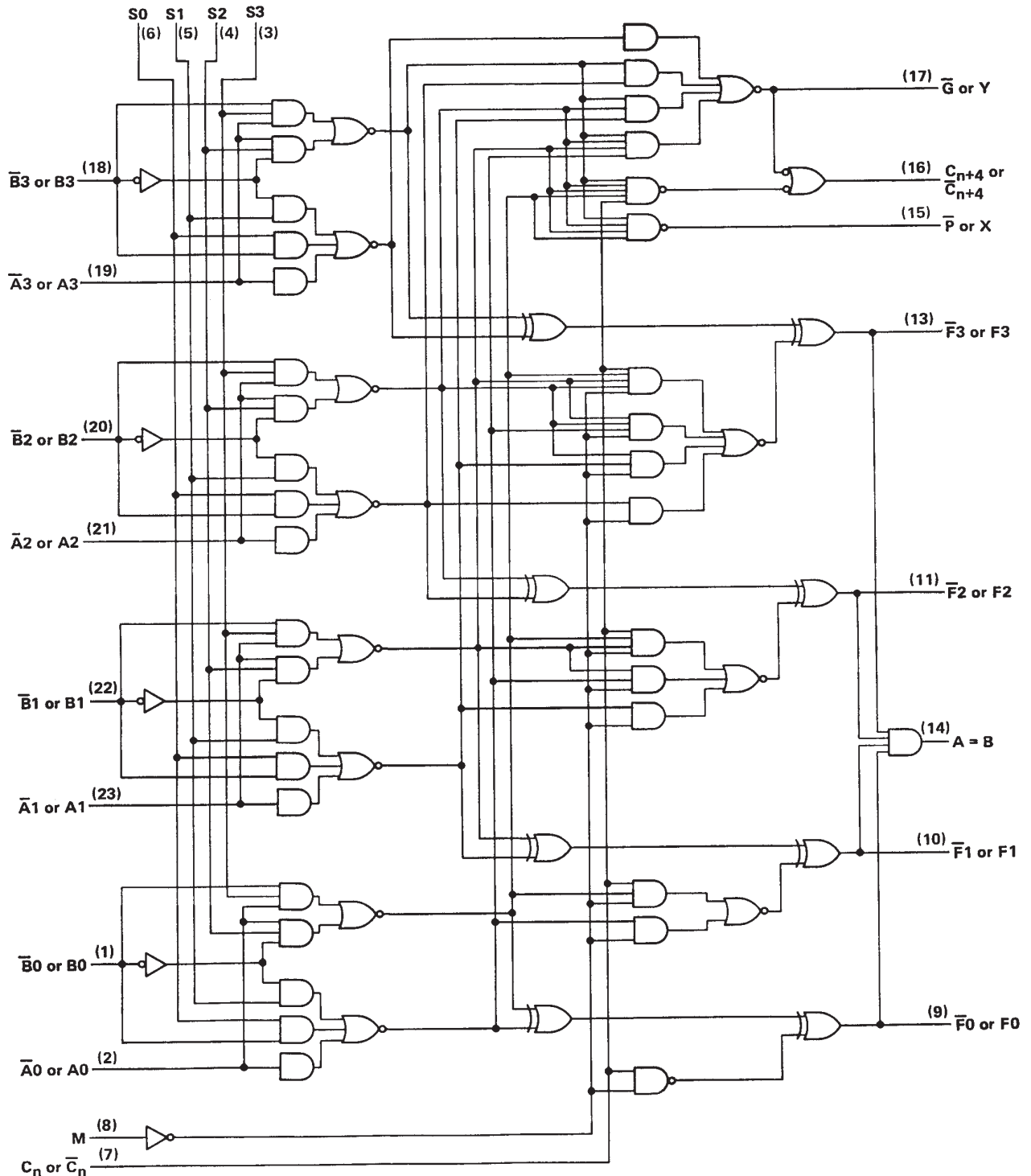

Pin numbers shown are for DW, J, N, and W packages.

**SN54LS181, SN54S181**  
**SN74LS181, SN74S181**  
**ARITHMETIC LOGIC UNITS/FUNCTION GENERATORS**

SDLS136 – DECEMBER 1972 – REVISED MARCH 1988

**absolute maximum ratings over recommended operating free-air temperature range (unless otherwise noted)**

Supply voltage, $V_{CC}$ (see Note 1)	7 V
Input voltage	5.5 V
Interemitter voltage (see Note 2)	5.5 V
Operating free-air temperature range: SN54LS181	-55°C to 125°C
SN74LS181	0°C to 70°C
Storage temperature range	-65°C to 150°C

- NOTES: 1. Voltage values, except interemitter voltage, are with respect to network ground terminal.  
2. This is the voltage between two emitters of a multiple-emitter transistor. For this circuit, this rating applies to each  $\bar{A}$  input in conjunction with inputs S2 or S3, and to each  $\bar{B}$  input in conjunction with inputs S0 or S3.

**recommended operating conditions**

	SN54LS181			SN74LS181			UNIT
	MIN	NOM	MAX	MIN	NOM	MAX	
Supply voltage, $V_{CC}$	4.5	5	5.5	4.75	5	5.25	V
High-level output current, $I_{OH}$ (All outputs except A = B)			-400			-400	$\mu$ A
Low-level output current, $I_{OL}$			4			8	mA
Operating free-air temperature, $T_A$	-55		125	0		70	°C

**electrical characteristics over recommended operating free-air temperature range (unless otherwise noted)**

PARAMETER		TEST CONDITIONS†	SN54LS181		SN74LS181		UNIT	
			MIN	TYP‡	MAX	MIN		TYP‡
$V_{IH}$	High-level input voltage		2		2		V	
$V_{IL}$	Low-level input voltage			0.7		0.8	V	
$V_{IK}$	Input clamp voltage	$V_{CC} = \text{MIN}, I_I = -18 \text{ mA}$		-1.5		-1.5	V	
$V_{OH}$	High-level output voltage, any output except A = B	$V_{CC} = \text{MIN}, V_{IH} = 2 \text{ V}, V_{IL} = V_{IL \text{ max}}, I_{OH} = -400 \mu\text{A}$	2.5	3.4	2.7	3.4	V	
$I_{OH}$	High-level output current, A = B output only	$V_{CC} = \text{MIN}, V_{IH} = 2 \text{ V}, V_{IL} = V_{IL \text{ max}}, V_{OH} = 5.5 \text{ V}$		100		100	$\mu$ A	
$V_{OL}$	Low-level output voltage	All outputs $V_{CC} = \text{MIN}, V_{IH} = 2 \text{ V}, V_{IL} = V_{IL \text{ max}}$	$I_{OL} = 4 \text{ mA}$		0.25	0.4	0.25	0.4
			$I_{OL} = 8 \text{ mA}$				0.35	0.5
			$I_{OL} = 16 \text{ mA}$		0.47	0.7	0.47	0.7
			$I_{OL} = 8 \text{ mA}$		0.35	0.6	0.35	0.5
$I_I$	Input current at max. input voltage	Mode input Any $\bar{A}$ or $\bar{B}$ input Any S input Carry input $V_{CC} = \text{MAX}, V_I = 5.5 \text{ V}$		0.1		0.1	mA	
				0.3		0.3		
				0.4		0.4		
				0.5		0.5		
$I_{IH}$	High-level input current	Mode input Any $\bar{A}$ or $\bar{B}$ input Any S input Carry input $V_{CC} = \text{MAX}, V_I = 2.7 \text{ V}$		20		20	$\mu$ A	
				60		60		
				80		80		
				100		100		
$I_{IL}$	Low-level input current	Mode input Any $\bar{A}$ or $\bar{B}$ input Any S input Carry input $V_{CC} = \text{MAX}, V_I = 0.4 \text{ V}$		-0.4		-0.4	mA	
				-1.2		-1.2		
				-1.6		-1.6		
				-2		-2		
$I_{OS}$	Short-circuit output current, any output except A = B §	$V_{CC} = \text{MAX}$	-6	-40	-5	-42	mA	
$I_{CC}$	Supply current	$V_{CC} = \text{MAX},$ See Note 3	Condition A	20	32	20	34	mA
			Condition B	21	35	21	37	

† For conditions shown as MIN or MAX, use the appropriate value specified under recommended operating conditions.

‡ All typical values are at  $V_{CC} = 5 \text{ V}, T_A = 25^\circ \text{C}$ .

§ Not more than one output should be shorted at a time.

NOTE 3: With outputs open,  $I_{CC}$  is measured for the following conditions:  
A. S0 through S3, M, and  $\bar{A}$  inputs are at 4.5 V, all other inputs are grounded.  
B. S0 through S3 and M are at 4.5 V, all other inputs are grounded.



ARITHMETIC LOGIC UNITS/FUNCTION GENERATORS

SDLS136 - DECEMBER 1972 - REVISED MARCH 1988

switching characteristics,  $V_{CC} = 5\text{ V}$ ,  $T_A = 25^\circ\text{C}$ , ( $C_L = 15\text{ pF}$ ,  $R_L = 2\text{ k}\Omega$ , see note 4)

PARAMETER†	FROM (INPUT)	TO (OUTPUT)	TEST CONDITIONS	MIN	TYP	MAX	UNIT
$t_{PLH}$	$C_n$	$C_{n+4}$		18	27		ns
$t_{PHL}$				13	20		
$t_{PLH}$	Any $\bar{A}$ or $\bar{B}$	$C_{n+4}$	$M = 0\text{ V}$ , $S_0 = S_3 = 4.5\text{ V}$ , $S_1 = S_2 = 0\text{ V}$ (SUM mode)	25	38		ns
$t_{PHL}$				25	38		
$t_{PLH}$	Any $\bar{A}$ or $\bar{B}$	$C_{n+4}$	$M = 0\text{ V}$ , $S_0 = S_3 = 0\text{ V}$ , $S_1 = S_2 = 4.5\text{ V}$ (DIFF mode)	27	41		ns
$t_{PHL}$				27	41		
$t_{PLH}$	$C_n$	Any $\bar{F}$	$M = 0\text{ V}$ (SUM or DIFF mode)	17	26		ns
$t_{PHL}$				13	20		
$t_{PLH}$	Any $\bar{A}$ or $\bar{B}$	$\bar{G}$	$M = 0\text{ V}$ , $S_0 = S_3 = 4.5\text{ V}$ , $S_1 = S_2 = 0\text{ V}$ (SUM mode)	19	29		ns
$t_{PHL}$				15	23		
$t_{PLH}$	Any $\bar{A}$ or $\bar{B}$	$\bar{G}$	$M = 0\text{ V}$ , $S_0 = S_3 = 0\text{ V}$ , $S_1 = S_2 = 4.5\text{ V}$ (DIFF mode)	21	32		ns
$t_{PHL}$				21	32		
$t_{PLH}$	Any $\bar{A}$ or $\bar{B}$	$\bar{F}$	$M = 0\text{ V}$ , $S_0 = S_3 = 4.5\text{ V}$ , $S_1 = S_2 = 0\text{ V}$ , (SUM mode)	20	30		ns
$t_{PHL}$				20	30		
$t_{PLH}$	Any $\bar{A}$ or $\bar{B}$	$\bar{F}$	$M = 0\text{ V}$ , $S_0 = S_3 = 0\text{ V}$ , $S_1 = S_2 = 4.5\text{ V}$ (DIFF mode)	20	30		ns
$t_{PHL}$				22	33		
$t_{PLH}$	$\bar{A}_i$ or $\bar{B}_i$	$\bar{F}_i$	$M = 0\text{ V}$ , $S_0 = S_3 = 4.5\text{ V}$ , $S_1 = S_2 = 0\text{ V}$ (SUM mode)	21	32		ns
$t_{PHL}$				13	20		
$t_{PLH}$	$\bar{A}_i$ or $\bar{B}_i$	$\bar{F}_i$	$M = 0\text{ V}$ , $S_0 = S_3 = 0\text{ V}$ , $S_1 = S_2 = 4.5\text{ V}$ (DIFF mode)	21	32		ns
$t_{PHL}$				21	32		
$t_{PLH}$	$\bar{A}_i$ or $\bar{B}_i$	$\bar{F}_i$	$M = 4.5\text{ V}$ (logic mode)	22	33		ns
$t_{PHL}$				26	38		
$t_{PLH}$	Any $\bar{A}$ or $\bar{B}$	$A = B$	$M = 0\text{ V}$ , $S_0 = S_3 = 0\text{ V}$ , $S_1 = S_2 = 4.5\text{ V}$ (DIFF mode)	33	50		ns
$t_{PHL}$				41	62		

† $t_{PLH}$  = propagation delay time, low-to-high-level output

$t_{PHL}$  = propagation delay time, high-to-low-level output

NOTE 4: Load circuits and voltage waveforms are shown in Section 1. Refer to Parameter Measurement Information page for test conditions.

schematics of inputs and outputs

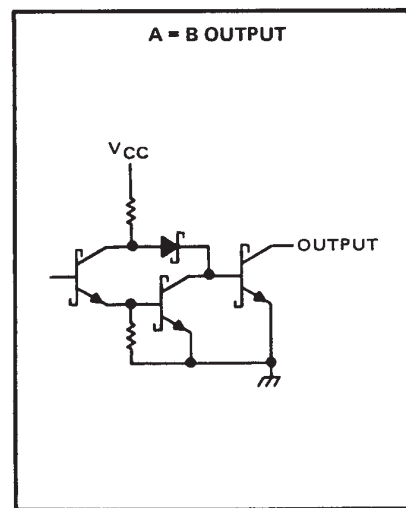
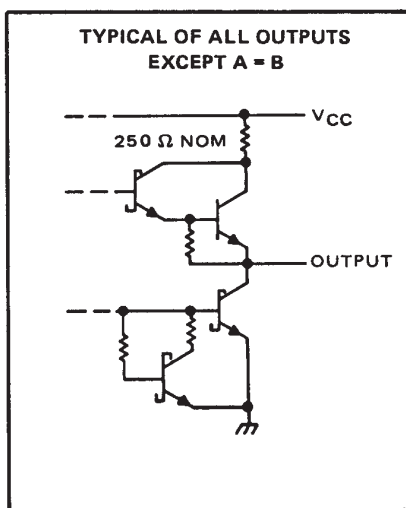
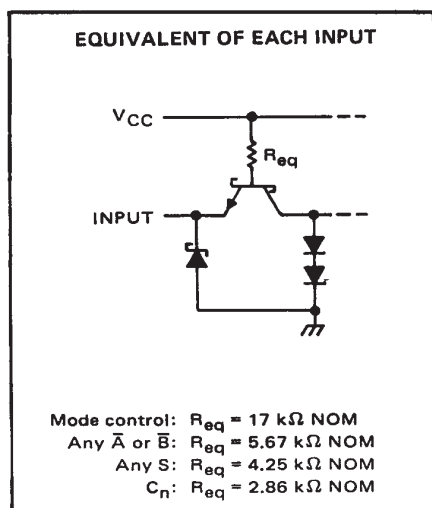



**SN54LS181, SN54S181**  
**SN74LS181, SN74S181**  
**ARITHMETIC LOGIC UNITS/FUNCTION GENERATORS**  
 SDLS136 – DECEMBER 1972 – REVISED MARCH 1988

**absolute maximum ratings over operating free-air temperature range (unless otherwise noted)**

Supply voltage, $V_{CC}$ (see Note 1)	7 V
Input voltage	5.5 V
Interemitter voltage (see Note 2)	5.5 V
Operating free-air temperature: SN54S181	-55°C to 125°C
SN74S181	0°C to 70°C
Storage temperature range	-65°C to 150°C

NOTES: 1. Voltage values, except interemitter voltage, are with respect to network ground terminal.  
 2. This is the voltage between two emitters of a multiple-emitter transistor. For this circuit, this rating applies to each  $\bar{A}$  input in conjunction with inputs S2 or S3, and to each  $\bar{B}$  input in conjunction with inputs S0 or S3.

**recommended operating conditions**

	SN54S181			SN74S181			UNIT
	MIN	NOM	MAX	MIN	NOM	MAX	
Supply voltage, $V_{CC}$	4.5	5	5.5	4.75	5	5.25	V
High-level output current, $I_{OH}$ (All outputs except A = B)			-1			-1	mA
Low-level output current, $I_{OL}$			20			20	mA
Operating free-air temperature, $T_A$	-55		125	0		70	°C

**electrical characteristics over recommended operating free-air temperature range (unless otherwise noted)**

PARAMETER	TEST CONDITIONS†	SN54S181			SN74S181			UNIT		
		MIN	TYP‡	MAX	MIN	TYP‡	MAX			
$V_{IH}$ High-level input voltage		2			2			V		
$V_{IL}$ Low-level input voltage				0.8			0.8	V		
$V_{IK}$ Input clamp voltage	$V_{CC} = \text{MIN}, I_I = -18 \text{ mA}$			-1.2			-1.2	V		
$V_{OH}$ High-level output voltage, any output except A = B	$V_{CC} = \text{MIN}, V_{IH} = 2 \text{ V}, V_{IL} = 0.8 \text{ V}, I_{OH} = -1 \text{ mA}$	2.5	3.4		2.7	3.4		V		
$I_{OH}$ High-level output current, A = B output only	$V_{CC} = \text{MIN}, V_{IH} = 2 \text{ V}, V_{IL} = 0.8 \text{ V}, V_{OH} = 5.5 \text{ V}$			250			250	µA		
$V_{OL}$ Low-level output voltage	$V_{CC} = \text{MIN}, V_{IH} = 2 \text{ V}, V_{IL} = 0.8 \text{ V}, I_{OL} = 20 \text{ mA}$			0.5			0.5	V		
$I_I$ Input current at maximum input voltage	$V_{CC} = \text{MAX}, V_I = 5.5 \text{ V}$			1			1	mA		
$I_{IH}$ High-level input current	Mode input			50			50	µA		
	Any $\bar{A}$ or $\bar{B}$ input	$V_{CC} = \text{MAX}, V_I = 2.5 \text{ V}$		150			150			
	Any S input			200			200			
	Carry input			250			250			
$I_{IL}$ Low-level input current	Mode input		$V_{CC} = \text{MAX}, V_I = 0.5 \text{ V}$		-2			-2	mA	
	Any $\bar{A}$ or $\bar{B}$ input			-6			-6			
	Any S input			-8			-8			
	Carry input			-10			-10			
$I_{OS}$ Short-circuit output current, any output except A = B §	$V_{CC} = \text{MAX}$			-40		-100	-40		-100	mA
$I_{CC}$ Supply current	$V_{CC} = \text{MAX}, T_A = 125^\circ\text{C},$ See Note 3	W package only		195						mA
	$V_{CC} = \text{MAX},$ See Note 3	All packages		120	220		120	220		

† For conditions shown as MIN or MAX, use the appropriate value specified under recommended operating conditions.

‡ All typical values are at  $V_{CC} = 5 \text{ V}, T_A = 25^\circ\text{C}$ .

§ Not more than one output should be shorted at a time.

NOTE 3:  $I_{CC}$  is measured for the following conditions (the typical and maximum values apply to both):

- A. S0 through S3, M, and  $\bar{A}$  inputs are at 4.5 V, all other inputs are grounded, and all outputs are open.
- B. S0 through S3 and M are at 4.5 V, all other inputs grounded, and all outputs are open.

ARITHMETIC LOGIC UNITS/FUNCTION GENERATORS

SDLS136 - DECEMBER 1972 - REVISED MARCH 1988

switching characteristics,  $V_{CC} = 5\text{ V}$ ,  $T_A = 25^\circ\text{C}$  ( $C_L = 15\text{ pF}$ ,  $R_L = 280\ \Omega$ , see note 4)

PARAMETER†	FROM (INPUT)	TO (OUTPUT)	TEST CONDITIONS	MIN	TYP	MAX	UNIT
t <sub>PLH</sub>	C <sub>n</sub>	C <sub>n+4</sub>		7	10.5	ns	
t <sub>PHL</sub>				7	10.5		
t <sub>PLH</sub>	Any $\bar{A}$ or $\bar{B}$	C <sub>n+4</sub>	M = 0 V, S0 = S3 = 4.5 V, S1 = S2 = 0 V (SUM mode)	12.5	18.5	ns	
t <sub>PHL</sub>				12.5	18.5		
t <sub>PLH</sub>	Any $\bar{A}$ or $\bar{B}$	C <sub>n+4</sub>	M = 0 V, S0 = S3 = 0 V, S1 = S2 = 4.5 V (DIFF mode)	15.5	23	ns	
t <sub>PHL</sub>				15.5	23		
t <sub>PLH</sub>	C <sub>n</sub>	Any $\bar{F}$	M = 0 V (SUM or DIFF mode)	7	12	ns	
t <sub>PHL</sub>				7	12		
t <sub>PLH</sub>	Any $\bar{A}$ or $\bar{B}$	$\bar{G}$	M = 0 V, S0 = S3 = 4.5 V, S1 = S2 = 0 V (SUM mode)	8	12	ns	
t <sub>PHL</sub>				7.5	12		
t <sub>PLH</sub>	Any $\bar{A}$ or $\bar{B}$	$\bar{G}$	M = 0 V, S0 = S3 = 0 V, S1 = S2 = 4.5 V (DIFF mode)	10.5	15	ns	
t <sub>PHL</sub>				10.5	15		
t <sub>PLH</sub>	Any $\bar{A}$ or $\bar{B}$	$\bar{P}$	M = 0 V, S0 = S3 = 4.5 V, S1 = S2 = 0 V (SUM mode)	7.5	12	ns	
t <sub>PHL</sub>				7.5	12		
t <sub>PLH</sub>	Any $\bar{A}$ or $\bar{B}$	$\bar{P}$	M = 0 V, S0 = S3 = 0 V, S1 = S2 = 4.5 V (DIFF mode)	10.5	15	ns	
t <sub>PHL</sub>				10.5	15		
t <sub>PLH</sub>	$\bar{A}_i$ or $\bar{B}_i$	$\bar{F}_i$	M = 0 V, S0 = S3 = 4.5 V, S1 = S2 = 0 V (SUM mode)	11	16.5	ns	
t <sub>PHL</sub>				11	16.5		
t <sub>PLH</sub>	$\bar{A}_i$ or $\bar{B}_i$	$F_i$	M = 0 V, S0 = S3 = 0 V, S1 = S2 = 4.5 V (DIFF mode)	14	20	ns	
t <sub>PHL</sub>				14	22		
t <sub>PLH</sub>	$\bar{A}_i$ or $\bar{B}_i$	$F_i$	M = 4.5 V (logic mode)	14	20	ns	
t <sub>PHL</sub>				14	22		
t <sub>PLH</sub>	Any $\bar{A}$ or $\bar{B}$	A = B	M = 0 V, S0 = S3 = 0 V, S1 = S2 = 4.5 V (DIFF mode)	15	23	ns	
t <sub>PHL</sub>				20	30		

†t<sub>PLH</sub> = propagation delay time, low-to-high-level output

t<sub>PHL</sub> = propagation delay time, high-to-low-level output

NOTE 4: Load circuits and voltage waveforms are shown in Section 1. Refer to Parameter Measurement Information page for test conditions.

schematics of inputs and outputs

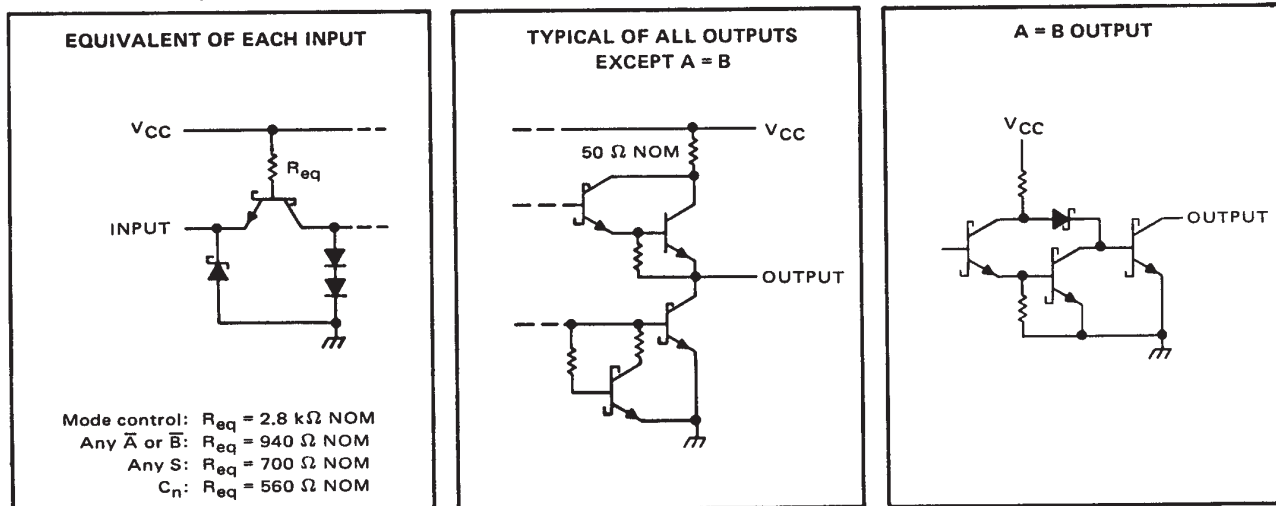

**SN54LS181, SN54S181**  
**SN74LS181, SN74S181**  
**ARITHMETIC LOGIC UNITS/FUNCTION GENERATORS**  
 SDLS136 – DECEMBER 1972 – REVISED MARCH 1988

**PARAMETER MEASUREMENT INFORMATION**

**SUM MODE TEST TABLE**  
 FUNCTION INPUTS: S0 = S3 = 4.5 V, S1 = S2 = M = 0 V

PARAMETER	INPUT UNDER TEST	OTHER INPUT SAME BIT		OTHER DATA INPUTS		OUTPUT UNDER TEST	OUTPUT WAVEFORM (See Note 4)
		APPLY 4.5 V	APPLY GND	APPLY 4.5 V	APPLY GND		
t <sub>PLH</sub> t <sub>PHL</sub>	$\bar{A}_i$	$\bar{B}_i$	None	Remaining $\bar{A}$ and $\bar{B}$	$C_n$	$\bar{F}_i$	In-Phase
t <sub>PLH</sub> t <sub>PHL</sub>	$\bar{B}_i$	$\bar{A}_i$	None	Remaining $\bar{A}$ and $\bar{B}$	$C_n$	$\bar{F}_i$	In-Phase
t <sub>PLH</sub> t <sub>PHL</sub>	$\bar{A}_i$	$\bar{B}_i$	None	None	Remaining $\bar{A}$ and $\bar{B}$ , $C_n$	$\bar{P}$	In-Phase
t <sub>PLH</sub> t <sub>PHL</sub>	$\bar{B}_i$	$\bar{A}_i$	None	None	Remaining $\bar{A}$ and $\bar{B}$ , $C_n$	$\bar{P}$	In-Phase
t <sub>PLH</sub> t <sub>PHL</sub>	$\bar{A}_i$	None	$\bar{B}_i$	Remaining $\bar{B}$	Remaining $\bar{A}$ , $C_n$	$\bar{G}$	In-Phase
t <sub>PLH</sub> t <sub>PHL</sub>	$\bar{B}_i$	None	$\bar{A}_i$	Remaining $\bar{B}$	Remaining $\bar{A}$ , $C_n$	$\bar{G}$	In-Phase
t <sub>PLH</sub> t <sub>PHL</sub>	$C_n$	None	None	All $\bar{A}$	All $\bar{B}$	Any $\bar{F}$ or $C_{n+4}$	In-Phase
t <sub>PLH</sub> t <sub>PHL</sub>	$\bar{A}_i$	None	$\bar{B}_i$	Remaining $\bar{B}$	Remaining $\bar{A}$ , $C_n$	$C_{n+4}$	Out-of-Phase
t <sub>PLH</sub> t <sub>PHL</sub>	$\bar{B}_i$	None	$\bar{A}_i$	Remaining $\bar{B}$	Remaining $\bar{A}$ , $C_n$	$C_{n+4}$	Out-of-Phase

**DIFF MODE TEST TABLE**

FUNCTION INPUTS: S1 = S2 = 4.5 V, S0 = S3 = M = 0 V

PARAMETER	INPUT UNDER TEST	OTHER INPUT SAME BIT		OTHER DATA INPUTS		OUTPUT UNDER TEST	OUTPUT WAVEFORM (See Note 4)
		APPLY 4.5 V	APPLY GND	APPLY 4.5 V	APPLY GND		
t <sub>PLH</sub> t <sub>PHL</sub>	$\bar{A}_i$	None	$\bar{B}_i$	Remaining $\bar{A}$	Remaining $\bar{B}$ , $C_n$	$\bar{F}_i$	In-Phase
t <sub>PLH</sub> t <sub>PHL</sub>	$\bar{B}_i$	$\bar{A}_i$	None	Remaining $\bar{A}$	Remaining $\bar{B}$ , $C_n$	$\bar{F}_i$	Out-of-Phase
t <sub>PLH</sub> t <sub>PHL</sub>	$\bar{A}_i$	None	$\bar{B}_i$	None	Remaining $\bar{A}$ and $\bar{B}$ , $C_n$	$\bar{P}$	In-Phase
t <sub>PLH</sub> t <sub>PHL</sub>	$\bar{B}_i$	$\bar{A}_i$	None	None	Remaining $\bar{A}$ and $\bar{B}$ , $C_n$	$\bar{P}$	Out-of-Phase
t <sub>PLH</sub> t <sub>PHL</sub>	$\bar{A}_i$	$\bar{B}_i$	None	None	Remaining $\bar{A}$ and $\bar{B}$ , $C_n$	$\bar{G}$	In-Phase
t <sub>PLH</sub> t <sub>PHL</sub>	$\bar{B}_i$	None	$\bar{A}_i$	None	Remaining $\bar{A}$ and $\bar{B}$ , $C_n$	$\bar{G}$	Out-of-Phase
t <sub>PLH</sub> t <sub>PHL</sub>	$\bar{A}_i$	None	$\bar{B}_i$	Remaining $\bar{A}$	Remaining $\bar{B}$ , $C_n$	A = B	In-Phase
t <sub>PLH</sub> t <sub>PHL</sub>	$\bar{B}_i$	$\bar{A}_i$	None	Remaining $\bar{A}$	Remaining $\bar{B}$ , $C_n$	A = B	Out-of-Phase
t <sub>PLH</sub> t <sub>PHL</sub>	$C_n$	None	None	All $\bar{A}$ and $\bar{B}$	None	$C_{n+4}$ or any $\bar{F}$	In-Phase
t <sub>PLH</sub> t <sub>PHL</sub>	$\bar{A}_i$	$\bar{B}_i$	None	None	Remaining $\bar{A}$ , $\bar{B}$ , $C_n$	$C_{n+4}$	Out-of-Phase
t <sub>PLH</sub> t <sub>PHL</sub>	$\bar{B}_i$	None	$\bar{A}_i$	None	Remaining $\bar{A}$ , $\bar{B}$ , $C_n$	$C_{n+4}$	In-Phase

**LOGIC MODE TEST TABLE**

FUNCTION INPUTS: S1 = S2 = M = 4.5 V, S0 = S3 = 0 V

PARAMETER	INPUT UNDER TEST	OTHER INPUT SAME BIT		OTHER DATA INPUTS		OUTPUT UNDER TEST	OUTPUT WAVEFORM (See Note 4)
		APPLY 4.5 V	APPLY GND	APPLY 4.5 V	APPLY GND		
t <sub>PLH</sub> t <sub>PHL</sub>	$\bar{A}_i$	$\bar{B}_i$	None	None	Remaining $\bar{A}$ and $\bar{B}$ , $C_n$	$\bar{F}_i$	Out-of-Phase
t <sub>PLH</sub> t <sub>PHL</sub>	$\bar{B}_i$	$\bar{A}_i$	None	None	Remaining $\bar{A}$ and $\bar{B}$ , $C_n$	$\bar{F}_i$	Out-of-Phase

NOTE 4: Load circuits and voltage waveforms are shown in Section 1.

**PACKAGING INFORMATION**

Orderable Device	Status (1)	Package Type	Package Drawing	Pins	Package Qty	Eco Plan (2)	Lead/Ball Finish (6)	MSL Peak Temp (3)	Op Temp (°C)	Device Marking (4/5)	Samples
JM38510/07801BJA	ACTIVE	CDIP	J	24	1	TBD	Call TI	N / A for Pkg Type	-55 to 125	JM38510/07801BJA	Samples
M38510/07801BJA	ACTIVE	CDIP	J	24	1	TBD	Call TI	N / A for Pkg Type	-55 to 125	JM38510/07801BJA	Samples
SN54LS181J	ACTIVE	CDIP	J	24	1	TBD	Call TI	N / A for Pkg Type	-55 to 125	SN54LS181J	Samples
SN54S181J	ACTIVE	CDIP	J	24	1	TBD	Call TI	N / A for Pkg Type	-55 to 125	SN54S181J	Samples
SN74LS181N3	OBSOLETE	PDIP	N	24		TBD	Call TI	Call TI	0 to 70		
SN74S181J	OBSOLETE	CDIP	J	24		TBD	Call TI	Call TI	0 to 70		
SN74S181N	OBSOLETE	PDIP	N	24		TBD	Call TI	Call TI	0 to 70		
SN74S181N3	OBSOLETE	PDIP	N	24		TBD	Call TI	Call TI	0 to 70		
SNJ54LS181J	ACTIVE	CDIP	J	24	1	TBD	Call TI	N / A for Pkg Type	-55 to 125	SNJ54LS181J	Samples
SNJ54S181J	ACTIVE	CDIP	J	24	1	TBD	Call TI	N / A for Pkg Type	-55 to 125	SNJ54S181J	Samples
SNJ54S181W	ACTIVE	CFP	W	24	1	TBD	A42	N / A for Pkg Type	-55 to 125	SNJ54S181W	Samples

(1) The marketing status values are defined as follows:

**ACTIVE:** Product device recommended for new designs.

**LIFEBUY:** TI has announced that the device will be discontinued, and a lifetime-buy period is in effect.

**NRND:** Not recommended for new designs. Device is in production to support existing customers, but TI does not recommend using this part in a new design.

**PREVIEW:** Device has been announced but is not in production. Samples may or may not be available.

**OBSOLETE:** TI has discontinued the production of the device.

(2) Eco Plan - The planned eco-friendly classification: Pb-Free (RoHS), Pb-Free (RoHS Exempt), or Green (RoHS & no Sb/Br) - please check <http://www.ti.com/productcontent> for the latest availability information and additional product content details.

**TBD:** The Pb-Free/Green conversion plan has not been defined.

**Pb-Free (RoHS):** TI's terms "Lead-Free" or "Pb-Free" mean semiconductor products that are compatible with the current RoHS requirements for all 6 substances, including the requirement that lead not exceed 0.1% by weight in homogeneous materials. Where designed to be soldered at high temperatures, TI Pb-Free products are suitable for use in specified lead-free processes.

**Pb-Free (RoHS Exempt):** This component has a RoHS exemption for either 1) lead-based flip-chip solder bumps used between the die and package, or 2) lead-based die adhesive used between the die and leadframe. The component is otherwise considered Pb-Free (RoHS compatible) as defined above.

**Green (RoHS & no Sb/Br):** TI defines "Green" to mean Pb-Free (RoHS compatible), and free of Bromine (Br) and Antimony (Sb) based flame retardants (Br or Sb do not exceed 0.1% by weight in homogeneous material)

(3) MSL, Peak Temp. - The Moisture Sensitivity Level rating according to the JEDEC industry standard classifications, and peak solder temperature.



<sup>(4)</sup> There may be additional marking, which relates to the logo, the lot trace code information, or the environmental category on the device.

<sup>(5)</sup> Multiple Device Markings will be inside parentheses. Only one Device Marking contained in parentheses and separated by a "-" will appear on a device. If a line is indented then it is a continuation of the previous line and the two combined represent the entire Device Marking for that device.

<sup>(6)</sup> Lead/Ball Finish - Orderable Devices may have multiple material finish options. Finish options are separated by a vertical ruled line. Lead/Ball Finish values may wrap to two lines if the finish value exceeds the maximum column width.

**Important Information and Disclaimer:** The information provided on this page represents TI's knowledge and belief as of the date that it is provided. TI bases its knowledge and belief on information provided by third parties, and makes no representation or warranty as to the accuracy of such information. Efforts are underway to better integrate information from third parties. TI has taken and continues to take reasonable steps to provide representative and accurate information but may not have conducted destructive testing or chemical analysis on incoming materials and chemicals. TI and TI suppliers consider certain information to be proprietary, and thus CAS numbers and other limited information may not be available for release.

In no event shall TI's liability arising out of such information exceed the total purchase price of the TI part(s) at issue in this document sold by TI to Customer on an annual basis.

**OTHER QUALIFIED VERSIONS OF SN54LS181, SN54S181, SN74LS181, SN74S181 :**

● Catalog: [SN74LS181](#), [SN74S181](#)

● Military: [SN54LS181](#), [SN54S181](#)

NOTE: Qualified Version Definitions:

- Catalog - TI's standard catalog product
- Military - QML certified for Military and Defense Applications

MCDI004A – JANUARY 1995 – REVISED NOVEMBER 1997

**J (R-GDIP-T\*\*)**

**CERAMIC DUAL-IN-LINE PACKAGE**

24 PINS SHOWN

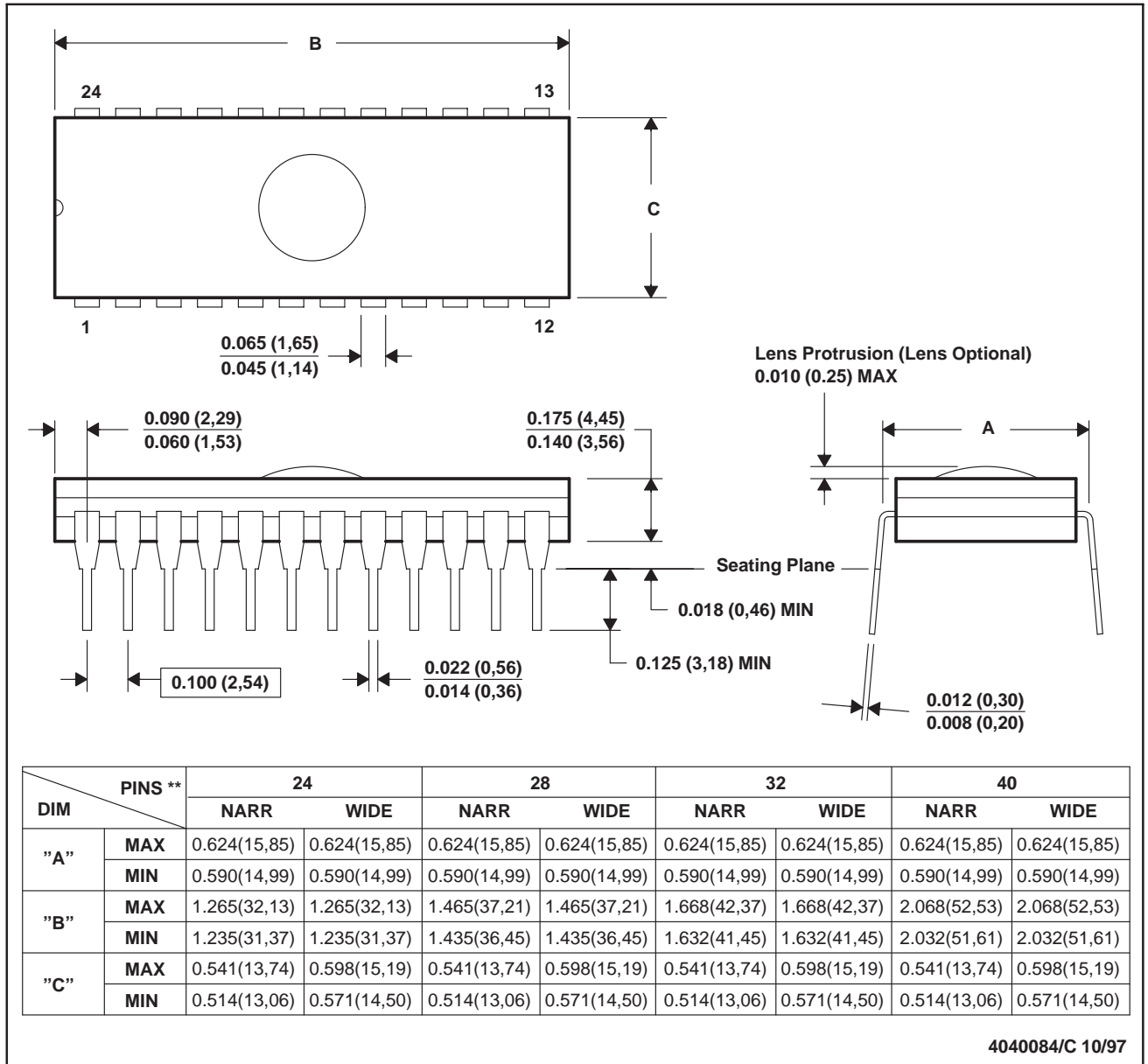

- NOTES: A. All linear dimensions are in inches (millimeters).  
 B. This drawing is subject to change without notice.  
 C. Window (lens) added to this group of packages (24-, 28-, 32-, 40-pin).  
 D. This package can be hermetically sealed with a ceramic lid using glass frit.  
 E. Index point is provided on cap for terminal identification.

**MECHANICAL DATA**

W (R-GDFP-F24)

CERAMIC DUAL FLATPACK

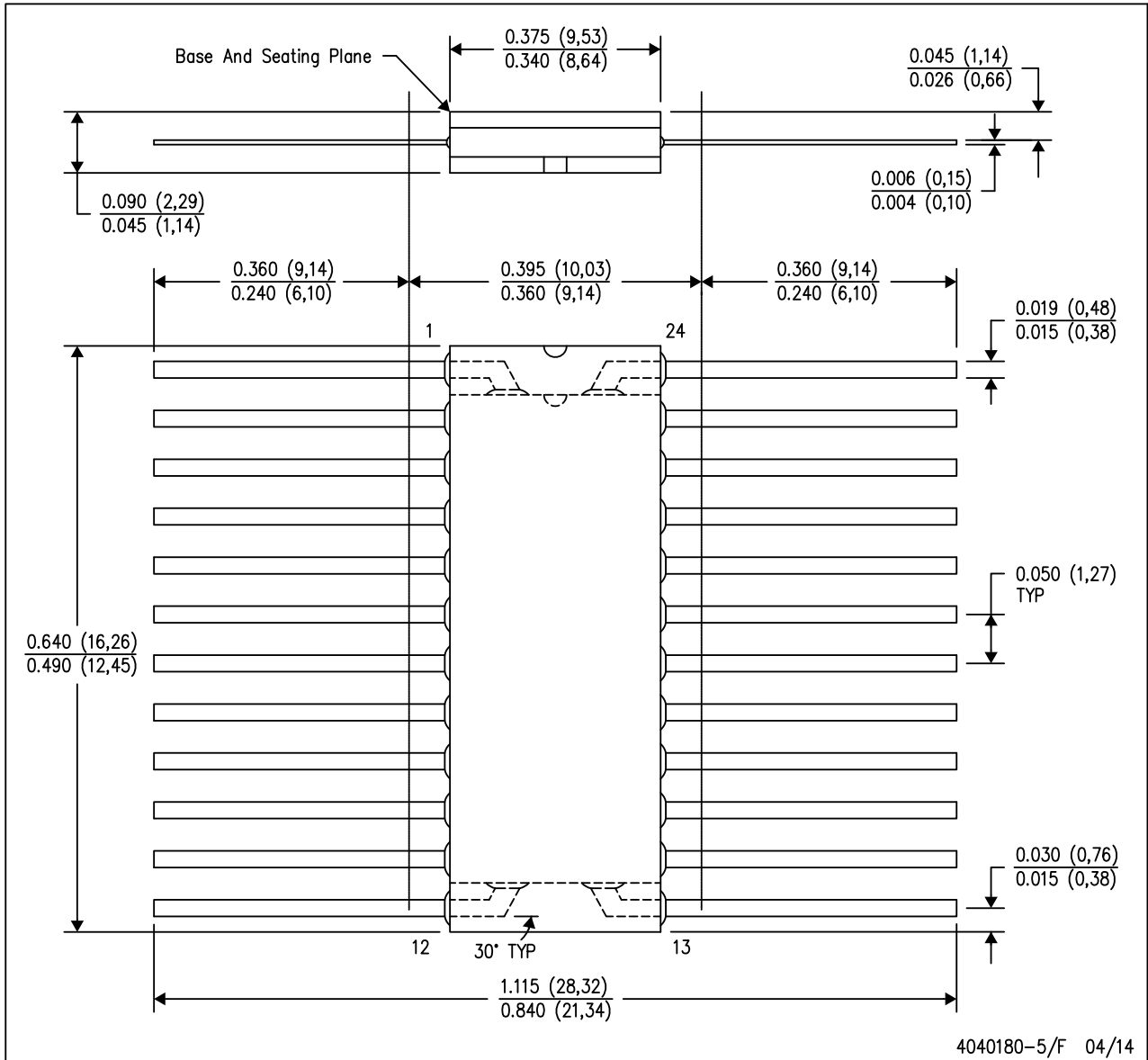

- NOTES:
- A. All linear dimensions are in inches (millimeters).
  - B. This drawing is subject to change without notice.
  - C. This package can be hermetically sealed with a ceramic lid using glass frit.
  - D. Index point is provided on cap for terminal identification only.
  - E. Falls within Mil-Std 1835 GDFP2-F20



**N (R-PDIP-T\*\*)**

**PLASTIC DUAL-IN-LINE PACKAGE**

24 PIN SHOWN

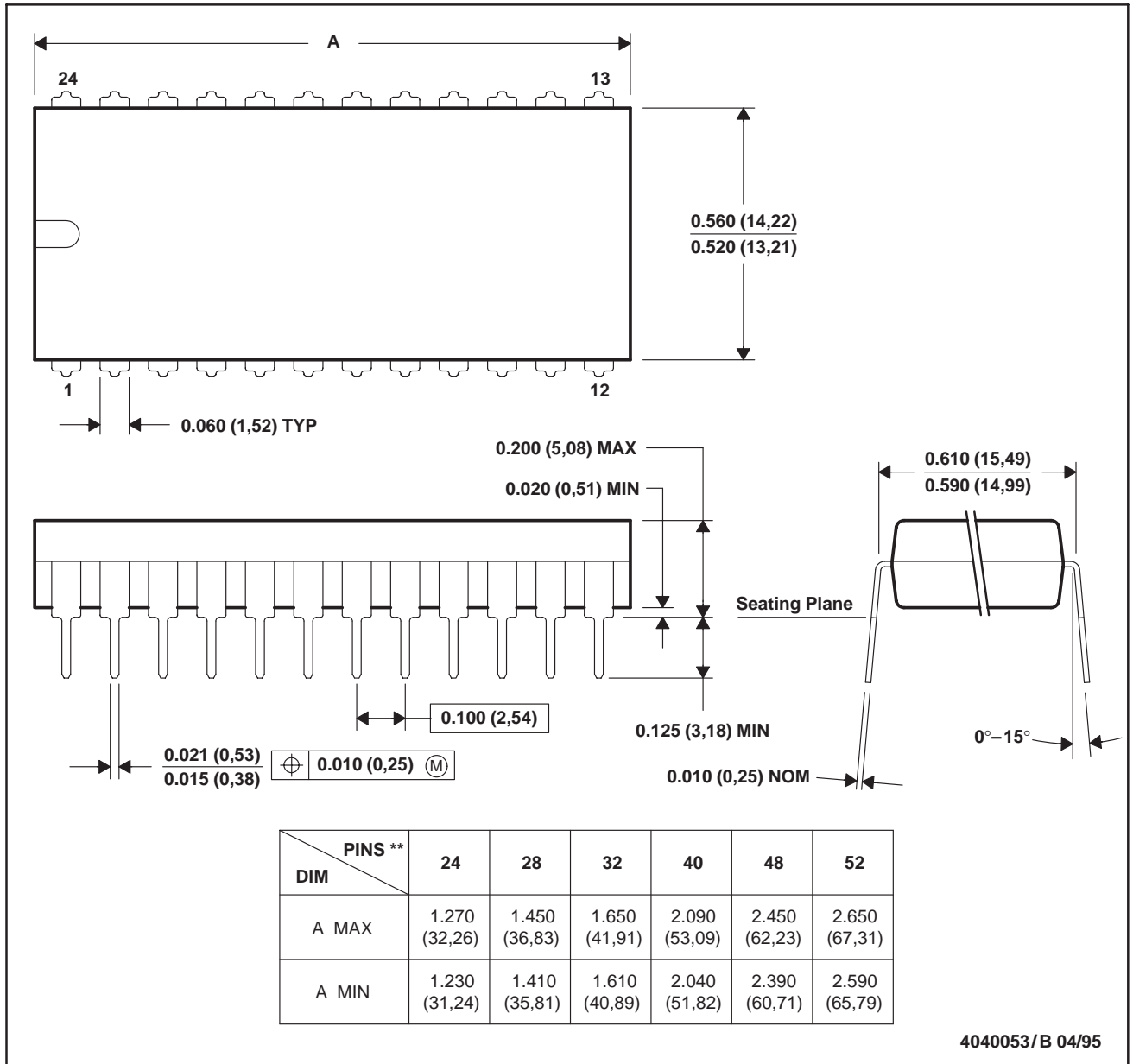

- NOTES: A. All linear dimensions are in inches (millimeters).  
 B. This drawing is subject to change without notice.  
 C. Falls within JEDEC MS-011  
 D. Falls within JEDEC MS-015 (32 pin only)

## IMPORTANT NOTICE

Texas Instruments Incorporated and its subsidiaries (TI) reserve the right to make corrections, enhancements, improvements and other changes to its semiconductor products and services per JESD46, latest issue, and to discontinue any product or service per JESD48, latest issue. Buyers should obtain the latest relevant information before placing orders and should verify that such information is current and complete. All semiconductor products (also referred to herein as "components") are sold subject to TI's terms and conditions of sale supplied at the time of order acknowledgment.

TI warrants performance of its components to the specifications applicable at the time of sale, in accordance with the warranty in TI's terms and conditions of sale of semiconductor products. Testing and other quality control techniques are used to the extent TI deems necessary to support this warranty. Except where mandated by applicable law, testing of all parameters of each component is not necessarily performed.

TI assumes no liability for applications assistance or the design of Buyers' products. Buyers are responsible for their products and applications using TI components. To minimize the risks associated with Buyers' products and applications, Buyers should provide adequate design and operating safeguards.

TI does not warrant or represent that any license, either express or implied, is granted under any patent right, copyright, mask work right, or other intellectual property right relating to any combination, machine, or process in which TI components or services are used. Information published by TI regarding third-party products or services does not constitute a license to use such products or services or a warranty or endorsement thereof. Use of such information may require a license from a third party under the patents or other intellectual property of the third party, or a license from TI under the patents or other intellectual property of TI.

Reproduction of significant portions of TI information in TI data books or data sheets is permissible only if reproduction is without alteration and is accompanied by all associated warranties, conditions, limitations, and notices. TI is not responsible or liable for such altered documentation. Information of third parties may be subject to additional restrictions.

Resale of TI components or services with statements different from or beyond the parameters stated by TI for that component or service voids all express and any implied warranties for the associated TI component or service and is an unfair and deceptive business practice. TI is not responsible or liable for any such statements.

Buyer acknowledges and agrees that it is solely responsible for compliance with all legal, regulatory and safety-related requirements concerning its products, and any use of TI components in its applications, notwithstanding any applications-related information or support that may be provided by TI. Buyer represents and agrees that it has all the necessary expertise to create and implement safeguards which anticipate dangerous consequences of failures, monitor failures and their consequences, lessen the likelihood of failures that might cause harm and take appropriate remedial actions. Buyer will fully indemnify TI and its representatives against any damages arising out of the use of any TI components in safety-critical applications.

In some cases, TI components may be promoted specifically to facilitate safety-related applications. With such components, TI's goal is to help enable customers to design and create their own end-product solutions that meet applicable functional safety standards and requirements. Nonetheless, such components are subject to these terms.

No TI components are authorized for use in FDA Class III (or similar life-critical medical equipment) unless authorized officers of the parties have executed a special agreement specifically governing such use.

Only those TI components which TI has specifically designated as military grade or "enhanced plastic" are designed and intended for use in military/aerospace applications or environments. Buyer acknowledges and agrees that any military or aerospace use of TI components which have **not** been so designated is solely at the Buyer's risk, and that Buyer is solely responsible for compliance with all legal and regulatory requirements in connection with such use.

TI has specifically designated certain components as meeting ISO/TS16949 requirements, mainly for automotive use. In any case of use of non-designated products, TI will not be responsible for any failure to meet ISO/TS16949.

### Products

Audio	<a href="http://www.ti.com/audio">www.ti.com/audio</a>
Amplifiers	<a href="http://amplifier.ti.com">amplifier.ti.com</a>
Data Converters	<a href="http://dataconverter.ti.com">dataconverter.ti.com</a>
DLP® Products	<a href="http://www.dlp.com">www.dlp.com</a>
DSP	<a href="http://dsp.ti.com">dsp.ti.com</a>
Clocks and Timers	<a href="http://www.ti.com/clocks">www.ti.com/clocks</a>
Interface	<a href="http://interface.ti.com">interface.ti.com</a>
Logic	<a href="http://logic.ti.com">logic.ti.com</a>
Power Mgmt	<a href="http://power.ti.com">power.ti.com</a>
Microcontrollers	<a href="http://microcontroller.ti.com">microcontroller.ti.com</a>
RFID	<a href="http://www.ti-rfid.com">www.ti-rfid.com</a>
OMAP Applications Processors	<a href="http://www.ti.com/omap">www.ti.com/omap</a>
Wireless Connectivity	<a href="http://www.ti.com/wirelessconnectivity">www.ti.com/wirelessconnectivity</a>

### Applications

Automotive and Transportation	<a href="http://www.ti.com/automotive">www.ti.com/automotive</a>
Communications and Telecom	<a href="http://www.ti.com/communications">www.ti.com/communications</a>
Computers and Peripherals	<a href="http://www.ti.com/computers">www.ti.com/computers</a>
Consumer Electronics	<a href="http://www.ti.com/consumer-apps">www.ti.com/consumer-apps</a>
Energy and Lighting	<a href="http://www.ti.com/energy">www.ti.com/energy</a>
Industrial	<a href="http://www.ti.com/industrial">www.ti.com/industrial</a>
Medical	<a href="http://www.ti.com/medical">www.ti.com/medical</a>
Security	<a href="http://www.ti.com/security">www.ti.com/security</a>
Space, Avionics and Defense	<a href="http://www.ti.com/space-avionics-defense">www.ti.com/space-avionics-defense</a>
Video and Imaging	<a href="http://www.ti.com/video">www.ti.com/video</a>

### TI E2E Community

[e2e.ti.com](http://e2e.ti.com)