



## Excellent Integrated System Limited

Stocking Distributor

Click to view price, real time Inventory, Delivery & Lifecycle Information:

[Panasonic Electronic Components](#)  
[AN26214A-PR](#)

For any questions, you can email us directly:

[sales@integrated-circuit.com](mailto:sales@integrated-circuit.com)

Code No.:	Total Pages	Page
	31	1

# Product Standards

Part No.	AN26214A
Package Code No.	XLGA011-W-1612-AN26214A

Analogue LSI Business Unit  
Semiconductor Company  
Matsushita Electric Industrial Co., Ltd.

Established by	Applied by	Checked by	Prepared by
S.Okada	M.Hiramatsu	M.Ishida	J.Ito

Established	Revised	
-------------	---------	--

	<h1>Product Standards</h1>	<b>AN26214A</b>	
		Total Pages	Page
		31	2

### Contents

■ Overview .....		3
■ Features .....		3
■ Applications .....		3
■ Package .....		3
■ Type .....		3
■ Application Circuit Example (Block Diagram).....		4
■ Pin Descriptions .....		5
■ Absolute Maximum Ratings .....		6
■ Operating Supply Voltage Range .....		6
■ Voltage and Current Ranges .....		7
■ Electrical Characteristics .....		8
■ Electrical Characteristics (Guaranteed design parameters).....		12
■ Control Pin Mode Table .....		25
■ Test Circuit Diagram .....		26
■ Technical Data .....		30
• I/O block circuit diagrams and pin function descriptions .....		30

Established	Revised	

	<h1>Product Standards</h1>	<h2>AN26214A</h2>	
		Total Pages	Page
		31	3

# AN26214A

## W-CDMA Triple Band LNA-IC

### ■ Overview

- AN26214A is LNA-IC for triple band (800 MHz / 2.1 GHz / 1.7GHz) WCDMA.
- Realizing high performance by using 0.18 mm SiGeC Bi-CMOS process ( $f_T = 90$  GHz,  $f_{max} = 140$  GHz).
- Each Band is selectable and Gain-mode is changeable, controlled by integrated CMOS logic circuit.
- Achieving miniaturization by using small size Wafer Level Chip Size Package (WLCSP).

### ■ Features

- Low voltage operation +2.85 V typ.
- Low current consumption
  - 3 mA typ. (High-Gain mode)
  - 11  $\mu$ A typ. (2GHz Low-Gain mode)
  - 25  $\mu$ A typ. (800 MHz/1.7 GHz Low-Gain mode)
- High gain(Gain)
  - 16.3 dB typ. fRX = 2140 MHz (High-Gain mode)
  - 16.3 dB typ. fRX = 884.5 MHz (High-Gain mode)
  - 16.3 dB typ. fRX = 1862.5 MHz (High-Gain mode)
- Low noise figure(NF)
  - 1.55 dB typ. fRX = 2140 MHz (High-Gain mode)
  - 1.25 dB typ. fRX = 884.5 MHz (High-Gain mode)
  - 1.35 dB typ. fRX = 1862.5 MHz (High-Gain mode)
- Low distortion
  - (IIP3 +10 MHz detuning) -6.0 dBm typ. fRX = 2140 MHz (High-Gain mode)
  - 2.0 dBm typ. fRX = 884.5 MHz (High-Gain mode)
  - 6.0 dBm typ. fRX = 1862.5 MHz (High-Gain mode)
- Small package(WLCSP)

### ■ Applications

- Triple-band W-CDMA handset.

### ■ Package

- 11 pin Wafer level chip size package (WLCSP)  
Size : 1.16 × 1.56 mm (0.4 mm pitch)

### ■ Type

- Bi-CMOS IC

Established	Revised	

<h1>Product Standards</h1>	<h2>AN26214A</h2>	
	Total Pages	Page
	31	4

■ Application Circuit Example (Block Diagram)

(Top View)

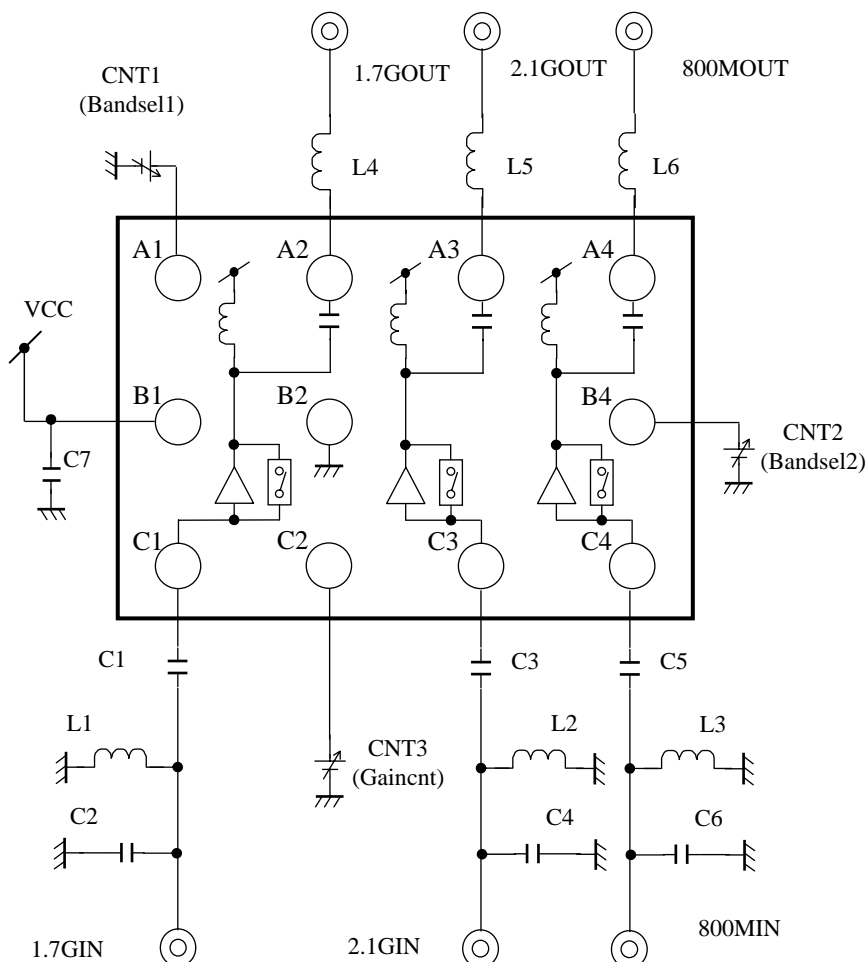

Part name	Chip size	Value	Model	Manufacturer
L1	1005	1 nH	ELJRF1NDF2	Panasonic
L2	1005	1.2 nH	ELJRF1N2DF2	Panasonic
L3	1005	3.3 nH	ELJRF3N3DF2	Panasonic
L4	1005	8.2 nH	ELJRF8N2JF2	Panasonic
L5	1005	5.6 nH	ELJRF5N6JF2	Panasonic
L6	1005	15 nH	ELJRF15NJF2	Panasonic
C1	1005	100 pF	ECJ0EB1H101K	Panasonic
C2	1005	2.7 pF	ECDG0E2R4B	Panasonic
C3	1005	100 pF	ECJ0EB1H101K	Panasonic
C4	1005	2.2 pF	ECDG0E2R2B	Panasonic
C5	1005	100 pF	ECJ0EB1H101K	Panasonic
C6	1005	6.8 pF	ECDG0E6R8C	Panasonic
C7	1005	10 pF//100 pF//1000 pF	ECJ0EB1H102K and other	Panasonic

Established	Revised
-------------	---------

	<h1>Product Standards</h1>	<b>AN26214A</b>	
		Total Pages	Page
		31	5

■ Pin Descriptions

Pin No.	Pin name	Type	Description
A1	CNT1	Input	Band SW1
A2	OUT1	Output	1.7 GHz RF Output
A3	OUT2	Output	2.1 GHz RF Output
A4	OUT3	Output	800 MHz RF Output
B1	V <sub>CC1</sub>	Power Supply	V <sub>CC</sub>
B2	GND	Ground	GND
B3	N.C.	-	N.C
B4	CNT2	Input	Band SW2
C1	IN1	Input	1.7 GHz RF Input
C2	CNT3	Input	High-Gain / Low-Gain SW
C3	IN2	Input	2.1 GHz RF Input
C4	IN3	Input	800 MHz RF Input

Established	Revised	

	<h1>Product Standards</h1>	<h2>AN26214A</h2>	
		Total Pages	Page
		31	6

■ Absolute Maximum Ratings

A No.	Parameter	Symbol	Rating	Unit	Notes
1	Supply voltage	$V_{CC}$	3.0	V	*1
2	Supply current	$I_{CC}$	20	mA	—
3	Power dissipation	$P_D$	50.8	mW	*2
4	Operating ambient temperature	$T_{opr}$	-20 to +85	°C	*3
5	Storage temperature	$T_{stg}$	-40 to +125	°C	*3

Notes)\*1: The values under the condition not exceeding the above absolute maximum ratings and the power dissipation.

\*2: The power dissipation shown is the value at  $T_a = 85^\circ\text{C}$  for the independent (unmounted) IC package.

When using this IC, refer to the  $P_D$ - $T_a$  diagram of the package standard and use under the condition not exceeding the allowable value.

\*3: Except for the power dissipation, operating ambient temperature, and storage temperature, all ratings are for  $T_a = 25^\circ\text{C}$ .

■ Operating supply voltage range

Parameter	Symbol	Range	Unit	Notes
Supply voltage range	$V_{CC}$	2.70 to 2.95	V	*

Note) \*: The values under the condition not exceeding the above absolute maximum ratings and the power dissipation.

Established	Revised	

	<h1>Product Standards</h1>	<h2>AN26214A</h2>	
		Total Pages	Page
		31	7

**■ Voltage and Current Ranges**

Note) • The ranges on the list are the voltages of respective pins in relation to GND.

- Do not apply the voltages or the currents from external into the pins which are not on the list.

Pin No.	Pin name	Range	Unit	Note
A1	CNT1	- 0.3 to (V <sub>CC</sub> )	V	—
A2	OUT1	- 0.3 to (V <sub>CC</sub> )	V	—
A3	OUT2	- 0.3 to (V <sub>CC</sub> )	V	—
A4	OUT3	- 0.3 to (V <sub>CC</sub> )	V	—
B1	V <sub>CC1</sub>	0 to 3.0	V	—
B2	GND	0	V	—
B3	N.C.	—	V	—
B4	CNT2	- 0.3 to (V <sub>CC</sub> )	V	—
C1	IN1	—	V	*1
C2	CNT3	- 0.3 to (V <sub>CC</sub> )	V	—
C3	IN2	—	V	*1
C4	IN3	—	V	*1

Note) \*1 : RF signal input pin. (Maximum input power is 0dBm.) Do not apply DC voltages.

Established	Revised	



	<h1>Product Standards</h1>	<b>AN26214A</b>	
		Total Pages	Page
		31	8

■ Electrical Characteristics at  $V_{CC} = 2.85\text{ V}$

Note)  $T_a = 25^\circ\text{C} \pm 2^\circ\text{C}$  unless otherwise specified.

B No.	Parameter	Symbol	Test circuits	Conditions	Limits			Unit	Notes
					Min	Typ	Max		
DC electrical characteristics									
DC-1	Circuit current HG (2.1 GHz)	IccHa	1	$V_{CC}$ current at 2.1 GHz High-Gain mode. No input signal	—	3.0	4.2	mA	—
DC-2	Circuit current HG (800 MHz)	IccHb	1	$V_{CC}$ current at 800 MHz High-Gain mode. No input signal	—	3.0	4.2	mA	—
DC-3	Circuit current HG (1.7 GHz)	IccHc	1	$V_{CC}$ current at 1.7 GHz High-Gain mode. No input signal	—	3.0	4.2	mA	—
DC-4	Circuit current LG (2.1 GHz)	IccLa	1	$V_{CC}$ current at 2.1 GHz Low-Gain mode. No input signal	—	11	60	$\mu\text{A}$	—
DC-5	Circuit current LG (800 MHz)	IccLb	1	$V_{CC}$ current at 800 MHz Low-Gain mode. No input signal	—	25	80	$\mu\text{A}$	—
DC-6	Circuit current LG (1.7 GHz)	IccLc	1	$V_{CC}$ current at 1.7 GHz Low-Gain mode. No input signal	—	25	80	$\mu\text{A}$	—
DC-7	SW voltage(High)	VIH	1	$VIH = V_{CC} \times 0.90$	2.57	2.85	3.0	V	—
DC-8	SW voltage(Low)	VIL	1	$VIL = V_{CC} \times 0.20$	0.0	—	0.6	V	—
DC-9	SW current(High)	IIH	1	Current at SW pin $VIH = V_{CC}$	—	10	30	$\mu\text{A}$	—
DC-10	SW current(Low)	IIL	1	Current at SW pin $VIL = 0\text{ V}$	—	0	30	$\mu\text{A}$	—

Established	Revised	

<h1>Product Standards</h1>	<h2>AN26214A</h2>	
	Total Pages	Page
	31	9

**■ Electrical Characteristics (continued)  $V_{CC} = 2.85\text{ V}$** 

 (Note)  $T_a = 25^\circ\text{C} \pm 2^\circ\text{C}$ ,  $f_{RXa} = 2\ 140\ \text{MHz}$ ,  $PRX = -30\ \text{dBm}$ , CW unless otherwise specified.

B No.	Parameter	Symbol	Test circuits	Conditions	Limits			Unit	Notes
					Min	Typ	Max		
2.1 GHz : AC electrical characteristics (High-Gain mode)									
A-1	Power Gain HG	GHSa	1	High-Gain mode $f = 2\ 140\ \text{MHz}$	14.8	16.3	18.0	dB	—
A-2	Power Gain LG	GLSa	1	Low-Gain mode $f = 2\ 140\ \text{MHz}$ , $PRX = -20\ \text{dBm}$	-9.5	-7.0	-4.5	dB	—
A-3	IIP3 +10 MHz detuning HG	IIP3H1Sa	1	High-Gain mode $f1 = f_{RXa} + 10\ \text{MHz}$ $f2 = f_{RXa} + 20\ \text{MHz}$ Input 2 signals ( $f1, f2$ )	-11.0	-6.0	—	dBm	—
A-4	IIP3 -10 MHz detuning HG	IIP3H2Sa	1	High-Gain mode $f1 = f_{RXa} - 10\ \text{MHz}$ $f2 = f_{RXa} - 20\ \text{MHz}$ Input 2 signals ( $f1, f2$ )	-11.0	0.0	—	dBm	—
A-5	IIP3 -95 MHz detuning HG	IIP3_2045 HSa	1	High-Gain mode $f1 = f_{RXa} - 190\ \text{MHz}$ $PRX1 = -27\ \text{dBm}$ $f2 = f_{RXa} - 95\ \text{MHz}$ $PRX2 = -33\ \text{dBm}$ Input 2 signals ( $f1, f2$ )	-6.0	-1.0	—	dBm	—
A-6	IIP3 -190 MHz detuning HG	IIP3_1760 HSa	1	High-Gain mode $f1 = f_{RXa} - 190\ \text{MHz}$ $PRX1 = -27\ \text{dBm}$ $f2 = f_{RXa} - 380\ \text{MHz}$ $PRX2 = -45\ \text{dBm}$ Input 2 signals ( $f1, f2$ )	-8.0	-4.5	—	dBm	—
A-7	Input P1dB TX undesired signal input HG	IP1dBHSa	1	High-Gain mode $f1 = 2170\ \text{MHz}$ , $PRX1 = -40\ \text{dBm}$ $f2 = 2170\ \text{MHz} - 190\ \text{MHz}$ Input 2 signals ( $f1, f2$ )	-19	-12	—	dBm	—

Established	Revised	

<h1>Product Standards</h1>	AN26214A	
	Total Pages	Page
	31	10

■ Electrical Characteristics (continued)  $V_{CC} = 2.85 V$

Note)  $T_a = 25^{\circ}C \pm 2^{\circ}C$ ,  $f_{RXa} = 2140 MHz$ ,  $PRX = -30 dBm$ , CW unless otherwise specified.

B No.	Parameter	Symbol	Test circuits	Conditions	Limits			Unit	Notes
					Min	Typ	Max		
800 MHz : LNA AC characteristics									
B-1	Power Gain HG	GHSb	2	High-Gain mode $f = 884.5 MHz$	14.8	16.3	18.0	dB	—
B-2	Power Gain LG	GLSb	2	Low-Gain mode $f = 884.5 MHz$ , $PRX = -20 dBm$	-7.5	-5.0	-2.5	dB	—
B-3	IIP3 +10 MHz detuning HG	IIP3H1Sb	2	High-Gain mode $f1 = f_{RXb} + 10 MHz$ $f2 = f_{RXb} + 20 MHz$ Input 2 signals ( $f1, f2$ )	-8.0	2.0	—	dBm	—
B-4	IIP3 -10 MHz detuning HG	IIP3H2Sb	2	High-Gain mode $f1 = f_{RXb} - 10 MHz$ $f2 = f_{RXb} - 20 MHz$ Input 2 signals ( $f1, f2$ )	-8.0	0.0	—	dBm	—
B-5	IIP3 -22.5 MHz detuning HG	IIP3_862 HSb	2	High-Gain mode $f1 = f_{RXb} - 45 MHz$ $PRX1 = -27 dBm$ $f2 = f_{RXb} - 22.5 MHz$ $PRX2 = -47 dBm$ Input 2 signals ( $f1, f2$ )	7.5	12.5	—	dBm	—
B-6	IIP3 -45 MHz detuning HG	IIP3_794.5 HSb	2	High-Gain mode $f1 = f_{RXb} - 45 MHz$ $PRX1 = -27 dBm$ $f2 = f_{RXb} - 90 MHz$ $PRX2 = -50 dBm$ Input 2 signals ( $f1, f2$ )	-5.5	2.0	—	dBm	—
B-7	Input P1dB TX undesired signal input HG	IP1dBHSb	2	High-Gain mode $f1 = f_{RXb}$ $PRX1 = -40 dBm$ $f2 = f_{RXb} - 45 MHz$ Input 2 signals ( $f1, f2$ )	-19	-12	—	dBm	—

Established	Revised	

<h1>Product Standards</h1>	<h2>AN26214A</h2>	
	Total Pages	Page
	31	11

**■ Electrical Characteristics (continued)  $V_{CC} = 2.85\text{ V}$** 

 (Note)  $T_a = 25^\circ\text{C} \pm 2^\circ\text{C}$ ,  $f_{RXa} = 2\,140\text{ MHz}$ ,  $PRX = -30\text{ dBm}$ , CW unless otherwise specified.

B No.	Parameter	Symbol	Test circuits	Conditions	Limits			Unit	Notes
					Min	Typ	Max		
1.7 GHz : LNA AC characteristics									
C-1	Power Gain HG	GHSc	3	High-Gain mode $f = 1\,862.5\text{ MHz}$	14.8	16.3	18.0	dB	—
C-2	Power Gain LG	GLSc	3	Low-Gain mode $f = 1\,862.5\text{ MHz}$ , $PRX = -20\text{ dBm}$	-10.5	-8.0	-5.5	dB	—
C-3	IIP3 +10 MHz detuning HG	IIP3H1Sc	3	High-Gain mode $f1 = f_{RXa} + 10\text{ MHz}$ $f2 = f_{RXa} + 20\text{ MHz}$ Input 2 signals ( $f1, f2$ )	-11.0	-6.0	—	dBm	—
C-4	IIP3 -10 MHz detuning HG	IIP3H2Sc	3	High-Gain mode $f1 = f_{RXa} - 10\text{ MHz}$ $f2 = f_{RXa} - 20\text{ MHz}$ Input 2 signals ( $f1, f2$ )	-11.0	-4.5	—	dBm	—
C-5	IIP3 -47.5 MHz detuning HG	IIP3_1815 HSc	3	High-Gain mode $f1 = f_{RXa} - 95\text{ MHz}$ $PRX1 = -27\text{ dBm}$ $f2 = f_{RXa} - 47.5\text{ MHz}$ $PRX2 = -33\text{ dBm}$ Input 2 signals ( $f1, f2$ )	-6.0	-1.0	—	dBm	—
C-6	IIP3 -95 MHz detuning HG	IIP3_1672.5 HSc	3	High-Gain mode $f1 = f_{RXa} - 95\text{ MHz}$ $PRX1 = -27\text{ dBm}$ $f2 = f_{RXa} - 190\text{ MHz}$ $PRX2 = -45\text{ dBm}$ Input 2 signals ( $f1, f2$ )	-6.5	-3.0	—	dBm	—
C-7	Input P1dB TX undesired signal input HG	IP1dBHSc	3	High-Gain mode $f1 = 1880\text{ MHz}$ , $PRX1 = -40\text{ dBm}$ $f2 = 1880\text{ MHz} - 95\text{ MHz}$ Input 2 signals ( $f1, f2$ )	-19	-12	—	dBm	—

Established	Revised	

<h1>Product Standards</h1>	<h2>AN26214A</h2>	
	Total Pages	Page
	31	12

**■ Electrical Characteristics (Reference values for design)  $V_{CC} = 2.85\text{ V}$** 

 Notes) •  $T_a = 25^\circ\text{C} \pm 2^\circ\text{C}$ ,  $f_{RXa} = 2\,110\text{ MHz}$  to  $2\,170\text{ MHz}$ ,  $PRX = -30\text{ dBm}$ , CW unless otherwise specified.

• The characteristics are logical values derived from the design of the IC and are not guaranteed by inspection.

If a problem does occur related to these characteristics, Matsushita will respond in good faith to user concerns.

B No.	Parameter	Symbol	Test circuits	Conditions	Limits			Unit	Notes
					Min	Typ	Max		
<b>2.1 GHz : LNA AC characteristics</b>									
D-1	Power Gain HG	GHa	1	High-Gain mode $f = f_{RXa}$	14.8	16.3	18.0	dB	—
D-2	Power Gain LG	GLa	1	Low-Gain mode $f = f_{RXa}$ , $PRX = -20\text{ dBm}$	-9.5	-7.0	-4.5	dB	—
D-3	Noise figure HG	NFHa	1	High-Gain mode $f = f_{RXa}$	—	1.55	1.90	dB	—
D-4	Noise figure LG	NFLa	1	Low-Gain mode $f = f_{RXa}$	—	7.0	10.0	dB	—
D-5	2nd intermodulation distortion Input level HG	IM2_190 Ha	1	High-Gain mode $f1 = f_{RXa} - 190\text{ MHz}$ $PRX1 = -27\text{ dBm}$ $f2 = 190\text{ MHz}$ $PRX2 = -75\text{ dBm}$ Input 2 signals ( $f1, f2$ )	—	-120	-113	dBm	—
D-6	2nd intermodulation distortion Input level HG	IM2_4090 Ha	1	High-Gain mode $f1 = f_{RX} - 190\text{ MHz}$ $PRX1 = -27\text{ dBm}$ $f2 = 2f_{RX} - 190\text{ MHz}$ $PRX2 = -35\text{ dBm}$ Input 2 signals ( $f1, f2$ )	—	-100	-95	dBm	—
D-7	IIP3 +10 MHz detuning HG	IIP3H1a	1	High-Gain mode $f1 = f_{RXa} + 10\text{ MHz}$ $f2 = f_{RXa} + 20\text{ MHz}$ Input 2 signals ( $f1, f2$ )	-11.0	-6.0	—	dBm	—
D-8	IIP3 -10 MHz detuning HG	IIP3H2a	1	High-Gain mode $f1 = f_{RXa} - 10\text{ MHz}$ $f2 = f_{RXa} - 20\text{ MHz}$ Input 2 signals ( $f1, f2$ )	-11.0	0.0	—	dBm	—
D-9	IIP3 -95 MHz detuning HG	IIP3_2045 Ha	1	High-Gain mode $f1 = f_{RXa} - 190\text{ MHz}$ $PRX1 = -27\text{ dBm}$ $f2 = f_{RXa} - 95\text{ MHz}$ $PRX2 = -33\text{ dBm}$ Input 2 signals ( $f1, f2$ )	-6.0	-1.0	—	dBm	—
D-10	IIP3 -190 MHz detuning HG	IIP3_1760 Ha	1	High-Gain mode $f1 = f_{RXa} - 190\text{ MHz}$ $PRX1 = -27\text{ dBm}$ $f2 = f_{RXa} - 380\text{ MHz}$ $PRX2 = -45\text{ dBm}$ Input 2 signals ( $f1, f2$ )	-8.0	-4.5	—	dBm	—

Established	Revised	

	<h1>Product Standards</h1>	<h2>AN26214A</h2>	
		Total Pages	Page
		31	13

■ Electrical Characteristics (Reference values for design) (continued)  $V_{CC} = 2.85 V$

Notes) •  $T_a = 25^{\circ}C \pm 2^{\circ}C$ ,  $f_{RXa} = 2\ 110\ MHz$  to  $2\ 170\ MHz$ ,  $PRX = -30\ dBm$ , CW unless otherwise specified.

• The characteristics are logical values derived from the design of the IC and are not guaranteed by inspection.

If a problem does occur related to these characteristics, Matsushita will respond in good faith to user concerns.

B No.	Parameter	Symbol	Test circuits	Conditions	Reference values			Unit	Notes
					Min	Typ	Max		
2.1 GHz : LNA AC characteristics									
D-11	IIP3 HG	IIP3_6040 Ha	1	High-Gain mode $f1 = f_{RX} - 190\ MHz$ $PRX1 = -27\ dBm$ $f2 = 2f1 + f_{RX}$ $PRX2 = -25\ dBm$ Input 2 signals ( $f1, f2$ )	-6.5	-1.5	—	dBm	—
D-12	Input P1dB TX undesired signal input HG	IP1dB Ha	1	High-Gain mode $f1 = f_{RX}$ $PRX1 = -40\ dBm$ $f2 = f_{RX} - 190\ MHz$ $PRX2 : Var.$ Input 2 signals ( $f1, f2$ )	-19	-12	—	dBm	—
D-13	Reverse isolation HG	ISOHa	1	High-Gain mode $f = f_{RXa}$	—	-30	-20	dB	—
D-14	Reverse isolation LG	ISOLa	1	Low-Gain mode $f = f_{RXa}$	—	-7.0	-4.0	dB	—
D-15	Input return loss HG	S11Ha	1	High-Gain mode $f = f_{RXa}$	7.0	8.0	—	dB	—
D-16	Input return loss LG	S11La	1	Low-Gain mode $f = f_{RXa}$	7.0	9.5	—	dB	—
D-17	Output return loss HG	S22Ha	1	High-Gain mode $f = f_{RXa}$	8.5	9.5	—	dB	—
D-18	Output return loss LG	S22La	1	Low-Gain mode $f = f_{RXa}$	8.5	9.5	—	dB	—

Established	Revised	

<h1>Product Standards</h1>	<h2>AN26214A</h2>	
	Total Pages	Page
	31	14

■ Electrical Characteristics (Reference values for design) (continued)  $V_{CC} = 2.85\text{ V}$

Notes) •  $T_a = 25^{\circ}\text{C} \pm 2^{\circ}\text{C}$ ,  $f_{RXb} = 869\text{ MHz}$  to  $900\text{ MHz}$ ,  $PRX = -30\text{ dBm}$ , CW unless otherwise specified.

• The characteristics are logical values derived from the design of the IC and are not guaranteed by inspection.

If a problem does occur related to these characteristics, Matsushita will respond in good faith to user concerns.

B No.	Parameter	Symbol	Test circuits	Conditions	Reference values			Unit	Notes
					Min	Typ	Max		
800 MHz : LNA AC characteristics									
E-1	Power Gain HG	GHb	2	High-Gain mode $f = f_{RXb}$	14.8	16.3	18.0	dB	—
E-2	Power Gain LG	GLb	2	Low-Gain mode $f = f_{RXb}$ $PRX = -20\text{ dBm}$	-7.5	-5.0	-2.5	dB	—
E-3	Noise figure HG	NFHb	2	High-Gain mode $f = f_{RXb}$	—	1.25	1.85	dB	—
E-4	Noise figure LG	NFLb	2	Low-Gain mode $f = f_{RXb}$	—	6.0	9.0	dB	—
E-5	2nd intermodulation distortion Input level HG	IM2_45 Hb	2	High-Gain mode $f1 = f_{RXb} - 45\text{ MHz}$ $PRX1 = -27\text{ dBm}$ $f2 = 45\text{ MHz}$ , $PRX2 = -55\text{ dBm}$ Input 2 signals ( $f1, f2$ )	—	-100	-90	dBm	—
E-6	2nd intermodulation distortion Input level HG	IM2_1715 Hb	2	High-Gain mode $f1 = f_{RX} - 45\text{ MHz}$ $PRX1 = -27\text{ dBm}$ $f2 = 2f_{RX} - 45\text{ MHz}$ $PRX2 = -50\text{ dBm}$ Input 2 signals ( $f1, f2$ )	—	-78	-72	dBm	—
E-7	IIP3 +10 MHz detuning HG	IIP3H1b	2	High-Gain mode $f1 = f_{RXb} + 10\text{ MHz}$ $f2 = f_{RXb} + 20\text{ MHz}$ Input 2 signals ( $f1, f2$ )	-8.0	2.0	—	dBm	—
E-8	IIP3 -10 MHz detuning HG	IIP3H2b	2	High-Gain mode $f1 = f_{RXb} - 10\text{ MHz}$ $f2 = f_{RXb} - 20\text{ MHz}$ Input 2 signals ( $f1, f2$ )	-8.0	0.0	—	dBm	—
E-9	IIP3 -22.5 MHz detuning HG	IIP3_862 Hb	2	High-Gain mode $f1 = f_{RXb} - 45\text{ MHz}$ $PRX1 = -27\text{ dBm}$ $f2 = f_{RXb} - 22.5\text{ MHz}$ $PRX2 = -47\text{ dBm}$ Input 2 signals ( $f1, f2$ )	7.5	12.5	—	dBm	—
E-10	IIP3 -45 MHz detuning HG	IIP3_794.5 Hb	2	High-Gain mode $f1 = f_{RXb} - 45\text{ MHz}$ $PRX1 = -27\text{ dBm}$ $f2 = f_{RXb} - 90\text{ MHz}$ $PRX2 = -50\text{ dBm}$ Input 2 signals ( $f1, f2$ )	-5.5	2.0	—	dBm	—

Established	Revised	

<h1>Product Standards</h1>	<h2>AN26214A</h2>	
	Total Pages	Page
	31	15

■ Electrical Characteristics (Reference values for design) (continued)  $V_{CC} = 2.85 V$

Notes) •  $T_a = 25^{\circ}C \pm 2^{\circ}C$ ,  $f_{RXb} = 869 MHz$  to  $900 MHz$ ,  $PRX = -30dBm$  unless otherwise specified.

• The characteristics are logical values derived from the design of the IC and are not guaranteed by inspection.

If a problem does occur related to these characteristics, Matsushita will respond in good faith to user concerns.

B No.	Parameter	Symbol	Test circuits	Conditions	Reference values			Unit	Notes
					Min	Typ	Max		
800 MHz : LNA AC characteristics									
E-11	IIP3 HG	IIP3_2563.5 Hb	2	High-Gain mode $f1 = f_{RX} - 45 MHz$ $PRX1 = -27 dBm$ $f2 = 2f1 + f_{RX}$ $PRX2 = -45 dBm$ Input 2 signals ( $f1, f2$ )	-5.0	5.0	—	dBm	—
E-12	Input P1dB TX undesired signal input HG	IP1dB Hb	2	High-Gain mode $f1 = f_{RXb}$ $PRX1 = -40 dBm$ $f2 = f_{RXb} - 45 MHz$ $PRX2 : Var.$ Input 2 signals ( $f1, f2$ )	-19	-12	—	dBm	—
E-13	Reverse isolation HG	ISOHb	2	High-Gain mode $f = f_{RXb}$	—	-24	-18	dB	—
E-14	Reverse isolation LG	ISOLb	2	Low-Gain mode $f = f_{RXb}$	—	-6.0	-3.0	dB	—
E-15	Input return loss HG	S11Hb	2	High-Gain mode $f = f_{RXb}$	8.5	9.5	—	dB	—
E-16	Input return loss LG	S11Lb	2	Low-Gain mode $f = f_{RXb}$	8.5	9.5	—	dB	—
E-17	Output return loss HG	S22Hb	2	High-Gain mode $f = f_{RXb}$	8.5	9.5	—	dB	—
E-18	Output return loss LG	S22Lb	2	Low-Gain mode $f = f_{RXb}$	8.5	9.5	—	dB	—

Established	Revised	



<h1>Product Standards</h1>	<h2>AN26214A</h2>	
	Total Pages	Page
	31	16

**■ Electrical Characteristics (Reference values for design) (continued)  $V_{CC} = 2.85\text{ V}$** 

 Notes) •  $T_a = 25^\circ\text{C} \pm 2^\circ\text{C}$ , fRXc = 1 844.9 MHz to 1 880 MHz, PRX = -30 dBm, CW unless otherwise specified.

• The characteristics are logical values derived from the design of the IC and are not guaranteed by inspection.

If a problem does occur related to these characteristics, Matsushita will respond in good faith to user concerns.

B No.	Parameter	Symbol	Test circuits	Conditions	Reference values			Unit	Notes
					Min	Typ	Max		
<b>1.7 GHz : LNA AC characteristics</b>									
F-1	Power Gain HG	GHc	3	High-Gain mode f = fRXc	14.8	16.3	18.0	dB	—
F-2	Power Gain LG	GLc	3	Low-Gain mode f = fRXc, PRX = -20 dBm	-10.5	-8.0	-5.5	dB	—
F-3	Noise figure HG	NFHc	3	High-Gain mode f = fRXc	—	1.35	1.95	dB	—
F-4	Noise figure LG	NFLc	3	Low-Gain mode f = fRXc	—	9.0	12.0	dB	—
F-5	2nd intermodulation distortion Input level HG	IM2_95 Hc	3	High-Gain mode f1 = fRXc - 95 MHz PRX1 = -27 dBm f2 = 95 MHz PRX2 = -75 dBm Input 2 signals (f1, f2)	—	-120	-113	dBm	—
F-6	2nd intermodulation distortion Input level HG	IM2_3630 Hc	3	High-Gain mode f1 = fRX - 95 MHz PRX1 = -27 dBm f2 = 2fRX - 95 MHz PRX2 = -35 dBm Input 2 signals (f1, f2)	—	-95	-90	dBm	—
F-7	IIP3 +10 MHz detuning HG	IIP3H1c	3	High-Gain mode f1 = fRXc + 10 MHz f2 = fRXc + 20 MHz Input 2 signals (f1, f2)	-11.0	-6.0	—	dBm	—
F-8	IIP3 -10 MHz detuning HG	IIP3H2c	3	High-Gain mode f1 = fRXc - 10 MHz f2 = fRXc - 20 MHz Input 2 signals (f1, f2)	-11.0	-4.5	—	dBm	—
F-9	IIP3 -47.5 MHz detuning HG	IIP3_1815 Hc	3	High-Gain mode f1 = fRXc - 95 MHz PRX1 = -27 dBm f2 = fRXc - 47.5 MHz PRX2 = -33 dBm Input 2 signals (f1, f2)	-6.0	-1.0	—	dBm	—
F-10	IIP3 -95 MHz detuning HG	IIP3_1672. 5 Hc	3	High-Gain mode f1 = fRXc - 95 MHz PRX1 = -27 dBm f2 = fRXc - 190 MHz PRX2 = -45 dBm Input 2 signals (f1, f2)	-6.5	-3.0	—	dBm	—

Established	Revised	

<h1 style="margin: 0;">Product Standards</h1>	AN26214A	
	Total Pages	Page
	31	17

■ Electrical Characteristics (Reference values for design) (continued)  $V_{CC} = 2.85 V$

Notes) •  $T_a = 25^{\circ}C \pm 2^{\circ}C$ ,  $f_{RXc} = 1\ 844.9\ MHz$  to  $1\ 880\ MHz$ ,  $PRX = -30\ dBm$ , CW unless otherwise specified.

• The characteristics are logical values derived from the design of the IC and are not guaranteed by inspection.

If a problem does occur related to these characteristics, Matsushita will respond in good faith to user concerns.

B No.	Parameter	Symbol	Test circuits	Conditions	Reference values			Unit	Notes
					Min	Typ	Max		
1.7 GHz : LNA AC characteristics									
F-11	IIP3 HG	IIP3_5397.5 Hc	3	High-Gain mode f1 = fRX - 95 MHz PRX1 = -27 dBm f2 = 2f1 + fRX PRX2 = -25 dBm Input 2 signals (f1, f2)	-4.0	1.0	—	dBm	—
F-12	Input P1dB TX undesired signal input HG	IP1dB H1c	3	High-Gain mode f1 = fRX PRX1 = -40 dBm f2 = fRX - 95 MHz PRX2 : Var. Input 2 signals (f1, f2)	-19	-12	—	dBm	—
F-13	Reverse isolation HG	ISOHc	3	High-Gain mode f = fRXc	—	-30	-20	dB	—
F-14	Reverse isolation LG	ISOLc	3	Low-Gain mode f = fRXc	—	-9.0	-6.0	dB	—
F-15	Input return loss HG	S11Hc	3	High-Gain mode f = fRXc	8.0	9.5	—	dB	—
F-16	Input return loss LG	S11Lc	3	Low-Gain mode f = fRXc	5.0	6.0	—	dB	—
F-17	Output return loss HG	S22Hc	3	High-Gain mode f = fRXc	7.0	9.5	—	dB	—
F-18	Output return loss LG	S22Lc	3	Low-Gain mode f = fRXc	8.5	9.5	—	dB	—

Established	Revised	

<h1>Product Standards</h1>	<h2>AN26214A</h2>	
	Total Pages	Page
	31	18

■ Electrical Characteristics (Reference values for design) (continued)  $V_{CC} = 2.7\text{ V to }2.95\text{ V}$

Notes) •  $T_a = 25^\circ\text{C} \pm 2^\circ\text{C}$  unless otherwise specified.

• The characteristics are logical values derived from the design of the IC and are not guaranteed by inspection.

If a problem does occur related to these characteristics, Matsushita will respond in good faith to user concerns.

B No.	Parameter	Symbol	Test circuits	Conditions	Reference values			Unit	Notes
					Min	Typ	Max		
DC characteristics									
DCT-1	Circuit current HG (2.1 GHz)	IccHTa	1	$V_{CC}$ current at 2.1 GHz High-Gain mode. No input signal	—	3.0	5.0	mA	—
DCT-2	Circuit current HG (800 MHz)	IccHTb	1	$V_{CC}$ current at 800 MHz High-Gain mode. No input signal	—	3.0	5.0	mA	—
DCT-3	Circuit current HG (1.7 GHz)	IccHTc	1	$V_{CC}$ current at 1.7 GHz High-Gain mode. No input signal	—	3.0	5.0	mA	—
DCT-4	Circuit current LG (2.1 GHz)	IccLTa	1	$V_{CC}$ current at 2.1 GHz Low-Gain mode. No input signal	—	11	80	$\mu\text{A}$	—
DCT-5	Circuit current LG (800 MHz)	IccLTb	1	$V_{CC}$ current at 800 MHz Low-Gain mode. No input signal	—	25	100	$\mu\text{A}$	—
DCT-6	Circuit current LG (1.7 GHz)	IccLTc	1	$V_{CC}$ current at 1.7 GHz Low-Gain mode. No input signal	—	25	100	$\mu\text{A}$	—

Established	Revised	

<h1>Product Standards</h1>	<h2>AN26214A</h2>	
	Total Pages	Page
	31	19

■ Electrical Characteristics (Reference values for design) (continued)  $V_{CC} = 2.7\text{ V to }2.95\text{ V}$

Notes) •  $T_a = -20^\circ\text{C to }85^\circ\text{C}$ ,  $f_{RXa} = 2\ 110\text{ MHz to }2\ 170\text{ MHz}$ ,  $PRX = -30\text{ dBm}$ , CW unless otherwise specified.

• The characteristics are logical values derived from the design of the IC and are not guaranteed by inspection.

If a problem does occur related to these characteristics, Matsushita will respond in good faith to user concerns.

B No.	Parameter	Symbol	Test circuits	Conditions	Reference values			Unit	Notes
					Min	Typ	Max		
2.1 GHz : LNA AC characteristics									
G-1	Power Gain HG	GHTa	1	High-Gain mode $f = f_{RXa}$	13.5	16.3	19.0	dB	—
G-2	Power Gain LG	GLTa	1	Low-Gain mode $f = f_{RXa}$ , $PRX = -20\text{ dBm}$	-10.0	-7.0	-4.0	dB	—
G-3	Noise figure HG	NFHTa	1	High-Gain mode $f = f_{RXa}$	—	1.55	2.25	dB	—
G-4	Noise figure LG	NFLTa	1	Low-Gain mode $f = f_{RXa}$	—	7.0	10.5	dB	—
G-5	2nd intermodulation distortion Input level HG	IM2_190 HTa	1	High-Gain mode $f1 = f_{RXa} - 190\text{ MHz}$ $PRX1 = -27\text{ dBm}$ $f2 = 190\text{ MHz}$ $PRX2 = -75\text{ dBm}$ Input 2 signals ( $f1, f2$ )	—	-120	-110	dBm	—
G-6	2nd intermodulation distortion Input level HG	IM2_4090 HTa	1	High-Gain mode $f1 = f_{RX} - 190\text{ MHz}$ $PRX1 = -27\text{ dBm}$ $f2 = 2f_{RX} - 190\text{ MHz}$ $PRX2 = -35\text{ dBm}$ Input 2 signals ( $f1, f2$ )	—	-100	-93	dBm	—
G-7	IIP3 +10 MHz detuning HG	IIP3H1Ta	1	High-Gain mode $f1 = f_{RXa} + 10\text{ MHz}$ $f2 = f_{RXa} + 20\text{ MHz}$ Input 2 signals ( $f1, f2$ )	-14.0	-6.0	—	dBm	—
G-8	IIP3 -10 MHz detuning HG	IIP3H2Ta	1	High-Gain mode $f1 = f_{RXa} - 10\text{ MHz}$ $f2 = f_{RXa} - 20\text{ MHz}$ Input 2 signals ( $f1, f2$ )	-14.0	-0.0	—	dBm	—
G-9	IIP3 -95 MHz detuning HG	IIP3_2045 HTa	1	High-Gain mode $f1 = f_{RXa} - 190\text{ MHz}$ $PRX1 = -27\text{ dBm}$ $f2 = f_{RXa} - 95\text{ MHz}$ $PRX2 = -33\text{ dBm}$ Input 2 signals ( $f1, f2$ )	-7.5	-1.0	—	dBm	—
G-10	IIP3 -190 MHz detuning HG	IIP3_1760 HTa	1	High-Gain mode $f1 = f_{RXa} - 190\text{ MHz}$ $PRX1 = -27\text{ dBm}$ $f2 = f_{RXa} - 380\text{ MHz}$ $PRX2 = -45\text{ dBm}$ Input 2 signals ( $f1, f2$ )	-10.0	-4.5	—	dBm	—

Established	Revised	

<h1>Product Standards</h1>	<h2>AN26214A</h2>	
	Total Pages	Page
	31	20

■ Electrical Characteristics (Reference values for design) (continued)  $V_{CC} = 2.7\text{ V to }2.95\text{ V}$

Notes) •  $T_a = -20^\circ\text{C to }85^\circ\text{C}$ ,  $f_{RXa} = 2\ 110\text{ MHz to }2\ 170\text{ MHz}$ ,  $PRX = -30\text{ dBm}$ , CW unless otherwise specified.

• The characteristics are logical values derived from the design of the IC and are not guaranteed by inspection.

If a problem does occur related to these characteristics, Matsushita will respond in good faith to user concerns.

B No.	Parameter	Symbol	Test circuits	Conditions	Reference values			Unit	Notes
					Min	Typ	Max		
2.1 GHz : LNA AC characteristics									
G-11	IIP3 HG	IIP3_6040 HTa	1	High-Gain mode f1 = fRX - 190 MHz PRX1 = -27 dBm f2 = 2f1 + fRX PRX2 = -25 dBm Input 2 signals (f1, f2)	-8.5	-1.5	—	dBm	—
G-12	Input P1dB TX undesired signal input HG	IP1dB HTa	1	High-Gain mode f1 = fRX PRX1 = -40 dBm f2 = fRX - 190 MHz PRX2 : Var. Input 2 signals (f1, f2)	-21	-12	—	dBm	—

Established	Revised	

<h1>Product Standards</h1>	<h2>AN26214A</h2>	
	Total Pages	Page
	31	21

**■ Electrical Characteristics (Reference values for design) (continued)  $V_{CC} = 2.7\text{ V}$  to  $2.95\text{ V}$** 

 Note) •  $T_a = -20^\circ\text{C}$  to  $85^\circ\text{C}$ ,  $f_{RXa} = 869\text{ MHz}$  to  $900\text{ MHz}$ ,  $PRX = -30\text{ dBm}$ , CW unless otherwise specified.

- The characteristics are logical values derived from the design of the IC and are not guaranteed by inspection.

If a problem does occur related to these characteristics, Matsushita will respond in good faith to user concerns.

B No.	Parameter	Symbol	Test circuits	Conditions	Reference values			Unit	Notes
					Min	Typ	Max		
<b>800 MHz : LNA AC characteristics</b>									
H-1	Power Gain HG	GHTb	2	High-Gain mode $f = f_{RXb}$	13.5	16.3	19.0	dB	—
H-2	Power Gain LG	GLTb	2	Low-Gain mode $f = f_{RXb}$ $PRX = -20\text{ dBm}$	-8.0	-5.0	-2.0	dB	—
H-3	Noise figure HG	NFHTb	2	High-Gain mode $f = f_{RXb}$	—	1.25	2.15	dB	—
H-4	Noise figure LG	NFLTb	2	Low-Gain mode $f = f_{RXb}$	—	6.0	9.5	dB	—
H-5	2nd intermodulation distortion Input level HG	IM2_45 HTb	2	High-Gain mode $f1 = f_{RXb} - 45\text{ MHz}$ $PRX1 = -27\text{ dBm}$ $f2 = 45\text{ MHz}$ , $PRX2 = -55\text{ dBm}$ Input 2 signals ( $f1, f2$ )	—	-100	-87	dBm	—
H-6	2nd intermodulation distortion Input level HG	IM2_1715 HTb	2	High-Gain mode $f1 = f_{RX} - 45\text{ MHz}$ $PRX1 = -27\text{ dBm}$ $f2 = 2f_{RX} - 45\text{ MHz}$ $PRX2 = -50\text{ dBm}$ Input 2 signals ( $f1, f2$ )	—	-78	-69	dBm	—
H-7	IIP3 +10 MHz detuning HG	IIP3H1Tb	2	High-Gain mode $f1 = f_{RXb} + 10\text{ MHz}$ $f2 = f_{RXb} + 20\text{ MHz}$ Input 2 signals ( $f1, f2$ )	-10.0	2.0	—	dBm	—
H-8	IIP3 -10 MHz detuning HG	IIP3H2Tb	2	High-Gain mode $f1 = f_{RXb} - 10\text{ MHz}$ $f2 = f_{RXb} - 20\text{ MHz}$ Input 2 signals ( $f1, f2$ )	-10.0	0.0	—	dBm	—
H-9	IIP3 -22.5 MHz detuning HG	IIP3_862 HTb	2	High-Gain mode $f1 = f_{RXb} - 45\text{ MHz}$ $PRX1 = -27\text{ dBm}$ $f2 = f_{RXb} - 22.5\text{ MHz}$ $PRX2 = -47\text{ dBm}$ Input 2 signals ( $f1, f2$ )	4.5	12.5	—	dBm	—
H-10	IIP3 -45 MHz detuning HG	IIP3_794.5 HTb	2	High-Gain mode $f1 = f_{RXb} - 45\text{ MHz}$ $PRX1 = -27\text{ dBm}$ $f2 = f_{RXb} - 90\text{ MHz}$ $PRX2 = -50\text{ dBm}$ Input 2 signals ( $f1, f2$ )	-8.0	2.0	—	dBm	—

Established	Revised	

<h1>Product Standards</h1>	<h2>AN26214A</h2>	
	Total Pages	Page
	31	22

■ Electrical Characteristics (Reference values for design) (continued)  $V_{CC} = 2.7\text{ V to }2.95\text{ V}$

Note) •  $T_a = -20^{\circ}\text{C to }85^{\circ}\text{C}$ ,  $f_{RXb} = 869\text{ MHz to }900\text{ MHz}$ ,  $PRX = -30\text{dBm}$  unless otherwise specified.

- The characteristics are logical values derived from the design of the IC and are not guaranteed by inspection.

If a problem does occur related to these characteristics, Matsushita will respond in good faith to user concerns.

B No.	Parameter	Symbol	Test circuits	Conditions	Reference values			Unit	Notes
					Min	Typ	Max		
800 MHz : LNA AC characteristics									
H-11	IIP3 HG	IIP3_2563.5 HTb	2	High-Gain mode f1 = fRX - 45 MHz PRX1 = -27 dBm f2 = 2f1 + fRX PRX2 = -45 dBm Input 2 signals (f1, f2)	-10	5	—	dBm	—
H-12	Input P1dB TX undesired signal input HG	IP1dB HTb	2	High-Gain mode f1 = fRXb PRX1 = -40 dBm f2 = fRXb - 45 MHz PRX2 : Var. Input 2 signals (f1, f2)	-21	-12	—	dBm	—

Established	Revised	

<h1>Product Standards</h1>	<h2>AN26214A</h2>	
	Total Pages	Page
	31	23

■ Electrical Characteristics (Reference values for design) (continued)  $V_{CC} = 2.7\text{ V to }2.95\text{ V}$

Note) •  $T_a = -20^\circ\text{C to }85^\circ\text{C}$ ,  $f_{RXa} = 1\,844.9\text{ MHz to }1\,880\text{ MHz}$ ,  $PRX = -30\text{ dBm}$ , CW unless otherwise specified.

• The characteristics are logical values derived from the design of the IC and are not guaranteed by inspection.

If a problem does occur related to these characteristics, Matsushita will respond in good faith to user concerns.

B No.	Parameter	Symbol	Test circuits	Conditions	Reference values			Unit	Notes
					Min	Typ	Max		
1.7 GHz : LNA AC characteristics									
I-1	Power Gain HG	GHTc	3	High-Gain mode $f = f_{RXc}$	13.5	16.3	19.0	dB	—
I-2	Power Gain LG	GLTc	3	Low-Gain mode $f = f_{RXc}$ , $PRX = -20\text{ dBm}$	-11.0	-8.0	-5.0	dB	—
I-3	Noise figure HG	NFHTc	3	High-Gain mode $f = f_{RXc}$	—	1.35	2.20	dB	—
I-4	Noise figure LG	NFLTc	3	Low-Gain mode $f = f_{RXc}$	—	9.0	12.5	dB	—
I-5	2nd intermodulation distortion Input level HG	IM2_95 HTc	3	High-Gain mode $f1 = f_{RXc} - 95\text{ MHz}$ $PRX1 = -27\text{ dBm}$ $f2 = 95\text{ MHz}$ $PRX2 = -75\text{ dBm}$ Input 2 signals ( $f1, f2$ )	—	-120	-110	dBm	—
I-6	2nd intermodulation distortion Input level HG	IM2_3630 HTc	3	High-Gain mode $f1 = f_{RX} - 95\text{ MHz}$ $PRX1 = -27\text{ dBm}$ $f2 = 2f_{RX} - 95\text{ MHz}$ $PRX2 = -35\text{ dBm}$ Input 2 signals ( $f1, f2$ )	—	-95	-88	dBm	—
I-7	IIP3 +10 MHz detuning HG	IIP3H1Tc	3	High-Gain mode $f1 = f_{RXc} + 10\text{ MHz}$ $f2 = f_{RXc} + 20\text{ MHz}$ Input 2 signals ( $f1, f2$ )	-14.0	-6.0	—	dBm	—
I-8	IIP3 -10 MHz detuning HG	IIP3H2Tc	3	High-Gain mode $f1 = f_{RXc} - 10\text{ MHz}$ $f2 = f_{RXc} - 20\text{ MHz}$ Input 2 signals ( $f1, f2$ )	-14.0	-4.5	—	dBm	—
I-9	IIP3 -47.5 MHz detuning HG	IIP3_1815 HTc	3	High-Gain mode $f1 = f_{RXc} - 95\text{ MHz}$ $PRX1 = -27\text{ dBm}$ $f2 = f_{RXc} - 47.5\text{ MHz}$ $PRX2 = -33\text{ dBm}$ Input 2 signals ( $f1, f2$ )	-7.5	-1.0	—	dBm	—
I-10	IIP3 -95 MHz detuning HG	IIP3_1672. 5 HTc	3	High-Gain mode $f1 = f_{RXc} - 95\text{ MHz}$ $PRX1 = -27\text{ dBm}$ $f2 = f_{RXc} - 190\text{ MHz}$ $PRX2 = -45\text{ dBm}$ Input 2 signals ( $f1, f2$ )	-8.5	-3.0	—	dBm	—

Established	Revised	



	<h1>Product Standards</h1>	<b>AN26214A</b>	
		Total Pages	Page
		31	24

■ Electrical Characteristics (Reference values for design) (continued)  $V_{CC} = 2.7\text{ V to }2.95\text{ V}$

Note) •  $T_a = -20^\circ\text{C to }85^\circ\text{C}$ ,  $f_{RXa} = 1\,844.9\text{ MHz to }1\,880\text{ MHz}$ ,  $PRX = -30\text{ dBm}$ , CW unless otherwise specified.

- The characteristics are logical values derived from the design of the IC and are not guaranteed by inspection.

If a problem does occur related to these characteristics, Matsushita will respond in good faith to user concerns.

B No.	Parameter	Symbol	Test circuits	Conditions	Reference values			Unit	Notes
					Min	Typ	Max		
1.7 GHz : LNA AC characteristics									
I-11	IIP3 HG	IIP3_5397.5 Hc	3	High-Gain mode f1 = fRX - 95 MHz PRX1 = -27 dBm f2 = 2f1 + fRX PRX2 = -25 dBm Input 2 signals (f1, f2)	-6.0	1.0	—	dBm	—
I-12	Input P1dB TX undesired signal input HG	IP1dB Hc	3	High-Gain mode f1 = fRX PRX1 = -40 dBm f2 = fRX - 95 MHz PRX2 : Var. Input 2 signals (f1, f2)	-21	-12	—	dBm	—

Established	Revised	

	<h1>Product Standards</h1>	<b>AN26214A</b>	
		Total Pages	Page
		31	25

■ Control Pin Mode Table

Note) See parameters B No.DC-7 to B No.DC-8 in the Electrical Characteristics for control voltage retention ranges.

CNT1 (Band Select1) (A1)	CNT2 (Band Select2) (B4)	CNT3 (Gain Control) (C2)	Band1 (2.1 GHz)	Band2 (800 MHz)	Band3 (1.7 GHz)	Mode
Low	Low	High	High-Gain	Off	Off	2.1 GHz High-Gain
		Low	Low-Gain	Off	Off	2.1 GHz Low-Gain
High	Low	High	Off	High-Gain	Off	800 MHz High-Gain
		Low	Off	Low-Gain	Off	800 MHz Low-Gain
Low	High	High	Off	Off	High-Gain	1.7 GHz High-Gain
		Low	Off	Off	Low-Gain	1.7 GHz Low-Gain
High	High	—	—	—	—	—

Established	Revised	

<h1>Product Standards</h1>	<h2>AN26214A</h2>	
	Total Pages	Page
	31	26

■ Test Circuit Diagram

Note) See "External parts" on Page29.

1. Test Circuit Diagram 1

(Top View)

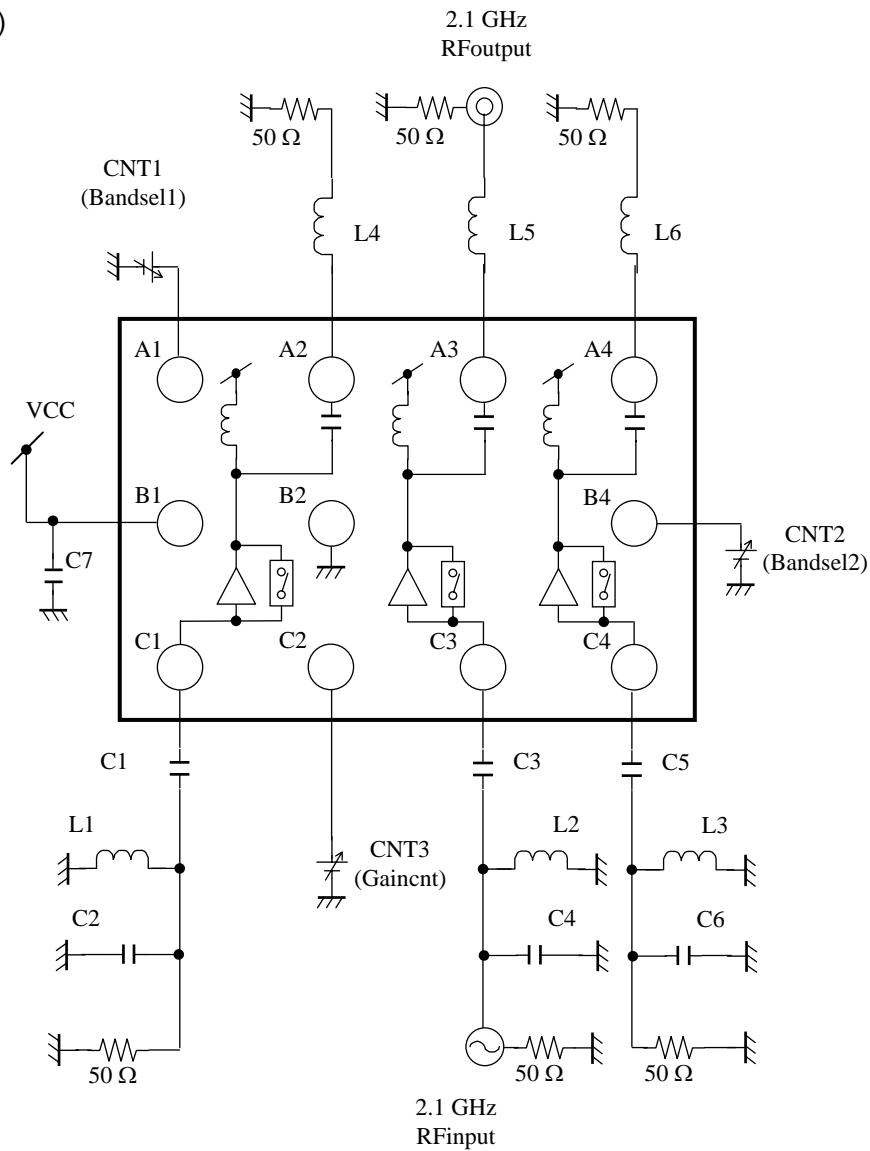

Established	Revised	

<h1>Product Standards</h1>	<h2>AN26214A</h2>	
	Total Pages	Page
	31	27

■ Test Circuit Diagram (continued)

Note) See "External parts" on Page29.

2. Test Circuit Diagram 2

(Top View)

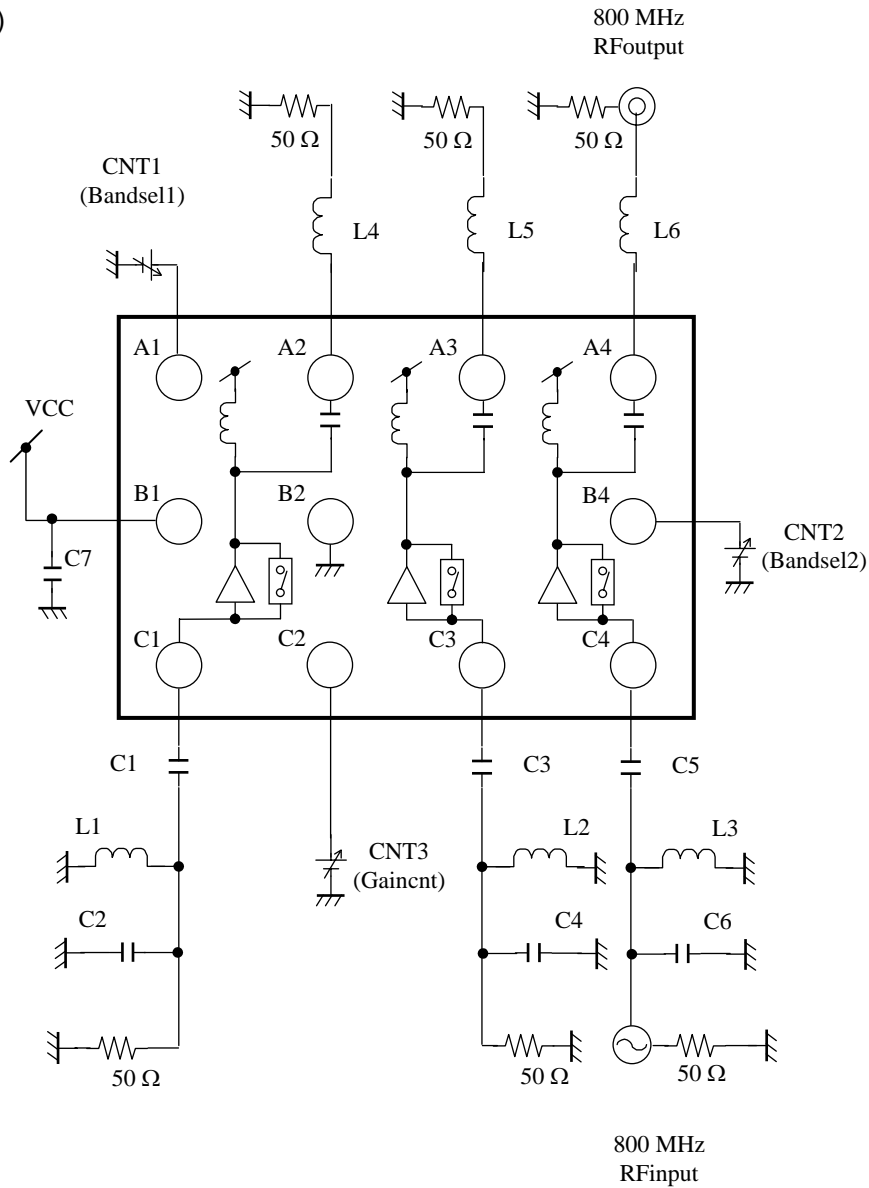

Established	Revised	

<h1>Product Standards</h1>	<h2>AN26214A</h2>	
	Total Pages	Page
	31	28

■ Test Circuit Diagram (continued)

Note) See "External parts" on Page29.

3. Test Circuit Diagram 3

(Top View)

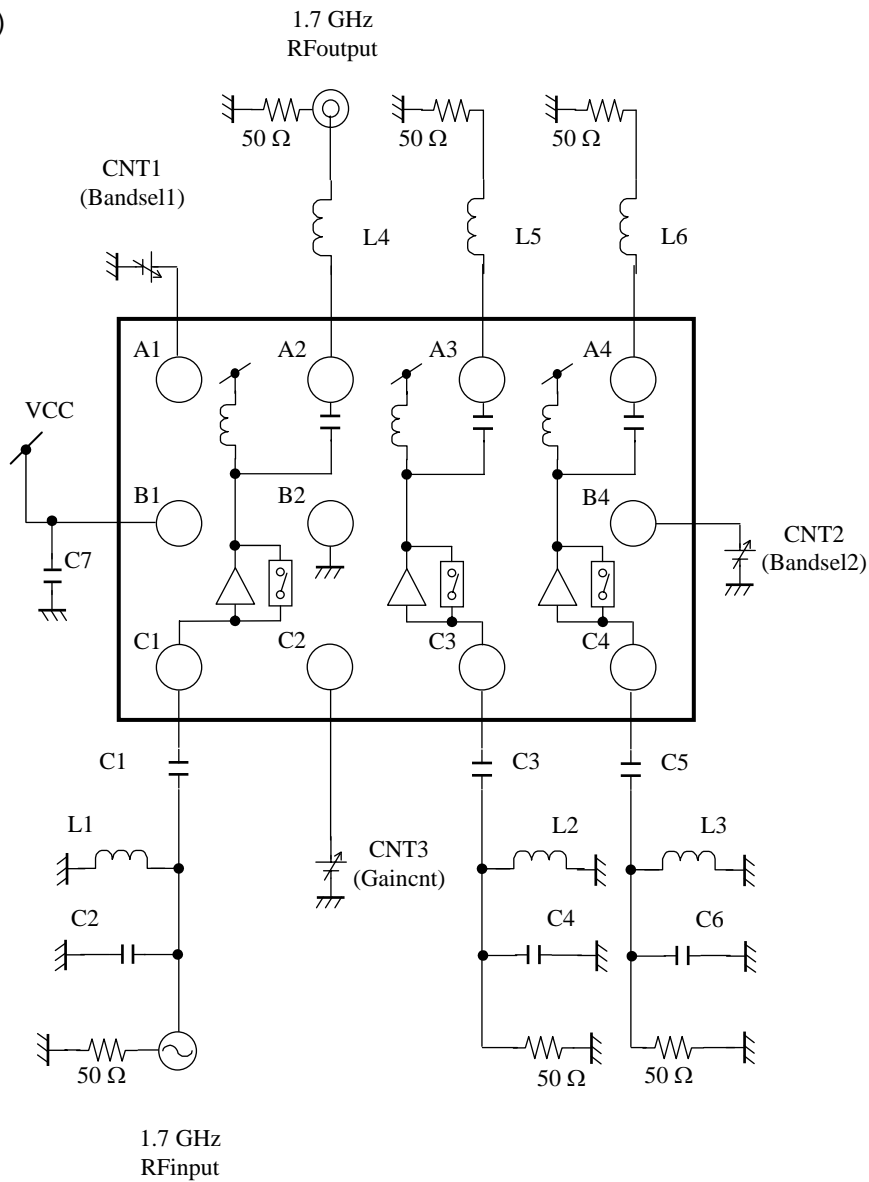

Established	Revised	

	<h1>Product Standards</h1>	<b>AN26214A</b>	
		Total Pages	Page
		31	29

■ Test Circuit Diagram (continued)

- External parts

Part name	Chip size	Value	Model	Manufacturer
L1	1005	1 nH	ELJRF1NDF2	Panasonic
L2	1005	1.2 nH	ELJRF1N2DF2	Panasonic
L3	1005	3.3 nH	ELJRF3N3DF2	Panasonic
L4	1005	8.2 nH	ELJRF8N2JF2	Panasonic
L5	1005	5.6 nH	ELJRF5N6JF2	Panasonic
L6	1005	15 nH	ELJRF15NJF2	Panasonic
C1	1005	100 pF	ECJ0EB1H101K	Panasonic
C2	1005	2.7 pF	ECDG0E2R4B	Panasonic
C3	1005	100 pF	ECJ0EB1H101K	Panasonic
C4	1005	2.2 pF	ECDG0E2R2B	Panasonic
C5	1005	100 pF	ECJ0EB1H101K	Panasonic
C6	1005	6.8 pF	ECDG0E6R8C	Panasonic
C7	1005	10 pF//100 pF//1000 pF	ECJ0EB1H102K and other	Panasonic

Established	Revised	

Product Standards	AN26214A	
	Total Pages	Page
	31	30

■ Technical Data

- I/O block circuit diagrams and pin function descriptions

Note) The characteristics listed below are reference values based on the IC design and are not guaranteed.

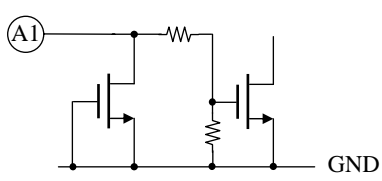
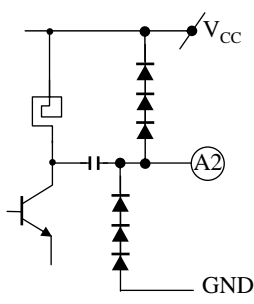
Pin No.	Voltage	Internal Circuit	Description
A1	—		2.1 GHz/800 MHz/1.7 GHz Band SW input 1 0.60 V( $V_{CC} \times 0.2$ ) or less : Low 2.57 V( $2.85 \times 0.9$ ) or more : High
A2	—		1.7 GHz LNA Output
A3	—	Refer to A2	2.1 GHz LNA Output
A4	—	Refer to A2	800 MHz LNA Output
B1	2.85 V	—	$V_{CC}$
B2	0.0 V	—	GND
B3	—	—	N.C.
B4	—	Refer to A1	2.1 GHz/800 MHz/1.7 GHz Band SW input2 0.60 V( $V_{CC} \times 0.2$ ) or less : Low 2.57 V( $2.85 \times 0.9$ ) or more : High

Established	Revised	
-------------	---------	--

	<h1>Product Standards</h1>	<b>AN26214A</b>	
		Total Pages	Page
		31	31

■ Technical Data (continued)

- I/O block circuit diagrams and pin function descriptions (continued)

Note) The characteristics listed below are reference values based on the IC design and are not guaranteed.

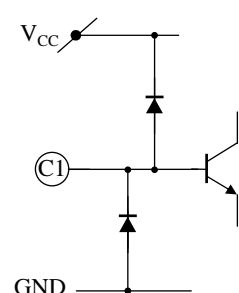
Pin No.	Voltage	Internal Circuit	Description
C1	0.75 V		1.7 GHz LNA Input
C2	—	Refer to A1	High-Gain/Low-Gain SW input 0.60 V( $V_{CC} \times 0.2$ ) or less : Low-Gain mode 2.57 V( $2.85 \times 0.9$ ) or more : High
C3	0.75 V	Refer to C1	2.1 GHz LNA Input
C4	0.75 V	Refer to C1	800 MHz LNA Input

Established	Revised	