

## Excellent Integrated System Limited

Stocking Distributor

Click to view price, real time Inventory, Delivery & Lifecycle Information:

[TDK-Lambda Americas, Inc.](#)

[DIN01](#)

For any questions, you can email us directly:

[sales@integrated-circuit.com](mailto:sales@integrated-circuit.com)

RoHS Compliance

REFER TO DL GROUP GREEN PROCUREMENT GUIDE LINE (DL-EMS-010\_).

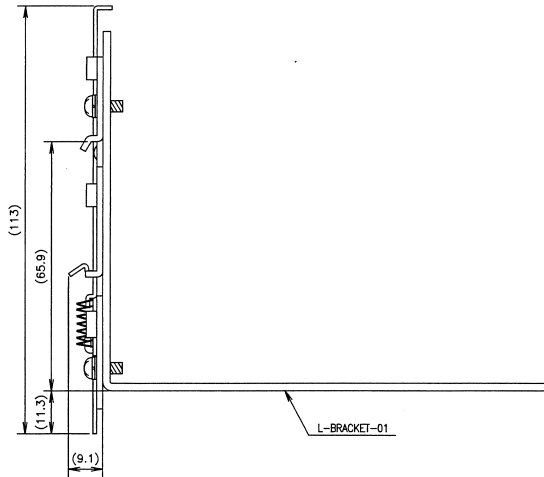
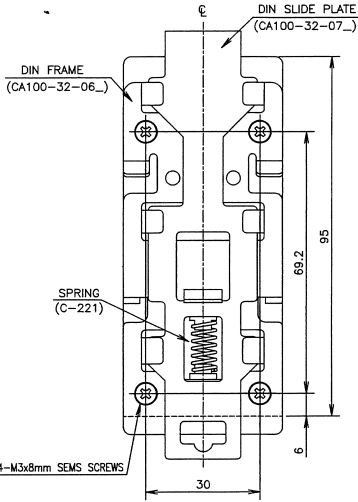
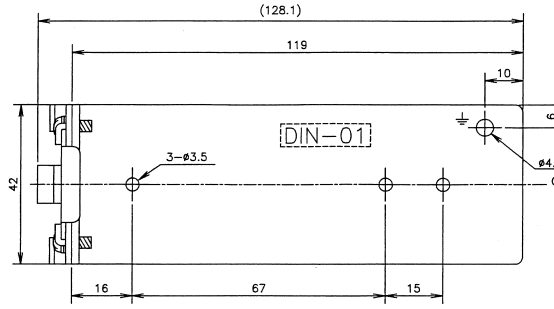

PARTS LIST

PARTS LIST	CATALOG No.	NET MANUFACTURE
1 DIN FRAME (CA100-32-06_)	CA100-32-06_ (ONWARD CA100-32-06C)	1 D-L
2 DIN SLIDE PLATE (CA100-32-07_)	CA100-32-07_ (ONWARD CA100-32-07C)	1 D-L
3 L-BLACKET-01	8000-3-667_	1 D-L
4 SPRING	C-221	1 KATO SPRING
5 SCREWS	M3x8mm SEMS	4 D-L



SCALE	1/1	MATERIALS	TITLE
UNITS	mm	SPCC-SD t=2.0	DIN-01(HWS15/30) MOUNTING PLATE
		FINISH	DRAWING No. 8000-3-664 -

-	-1	NEW RELEASE	29/2.1/05	43.Kanda	Fukuda	Shige
D	REV	CONTENTS	DATE	ENGR	CHK	APPD

3RD ANGLE PROJECTION

DENSEI-LAMBDA