

PFE700S SERIES

Instruction Manual

BEFORE USING THE POWER SUPPLY UNIT

Be sure to read this instruction manual thoroughly before using this product. Pay attention to all cautions and warnings before using this product. Incorrect usage could lead to an electrical shock, damage to the unit or a fire hazard.

WARNING

- Do not make unauthorized changes to power supply unit, otherwise you may have electric shock and void your warranty.
- Do not touch this unit and the internal components in operation or shortly after shut down. They may have high voltage or high temperature and as the unit dissipates its heat so the surface of the unit is hot. You may receive electric shock or burn.
- When the unit is operating, keep your hands and face away from it; you may be injured by an accident.
- Do not use unit under unusual condition such as emission of smoke or abnormal smell and sound etc. It might cause fire and electric shock. In such case, please contact us; do not repair by yourself, as it is dangerous for the user.
- Do not drop or insert anything into unit. It might cause failure and fire.
- Do not operate these units under condensation condition. It may cause fire and electric shock.

CAUTION

- As a component part, compliance with the standard will be based upon installation in the final application. This product must be installed in a restricted access location, accessible to authorized competent personnel only. These AC to DC converters have reinforced insulation between the input and the output. The outputs of these products are energy hazards. This model is considered to be non-SELV. As such, the instructions for use must refer to these energy hazardous outputs and Non-SELV outputs in that the outputs must not be accessible to the operator. The installer must also provide protection against inadvertent contact by a service engineer.
- The equipment has been evaluated for use in a Pollution Degree 2 environment.
- This power supply is primarily designed and manufactured to be used and enclosed in other equipment.
- Confirm connections to input/output terminals and signal terminals are correct as indicated in the instruction manual.
- Attach a HBC external fuse to each module to ensure safety operation and compliance to each safety standard approval. The recommended input fuse rating within the instructions is as follows: -15AHBC, 250V fast acting fuse. The breaking capacity and voltage rating of this fuse may be subject to the end use application.
- Input voltage, Output current, Output power, ambient temperature and ambient humidity should be used within specifications, otherwise the unit will be damaged.
- For application equipment, which requires very high reliability (Nuclear related equipment, traffic control equipment, medical equipment, etc.), please provide fail safety function in the equipment.
- Do not use the product in environment with strong electromagnetic field, corrosive gas and conductive substance.
- Do not operate and store this unit at an environment where condensation occurs. In such case, waterproof treatment is necessary.
- Never operate the unit under over current or shorted conditions for 30 seconds or more and out of Input Voltage Range as specification. Insulation failure, smoking, burning or other damage may occur to the unit.
- The output voltage of this power supply unit is considered to be a hazardous energy level (The voltage is 2V or more and the electric power is 240VA or more). Prevention from direct contact with output terminal is highly necessary. While installing or servicing this power supply unit, avoid dropping tools by mistake or direct contact with output terminal. This might cause an electrical shock. While repairing this power supply unit, the AC input power must be switched off and the input and output voltage should be level.
- To maintain the SELV output for outputs less than 28VDC, under fault conditions, the output must be connected to earth in the final application.
- The application circuits and their parameter are for reference only. Be sure to verify effectiveness of application circuits and their parameters before finalizing circuit design.
- Do not inject abnormal voltage to output terminal and signal terminal from the outside. The injection of reverse voltage or over voltage exceeding nominal output voltage to output terminals might cause damage to internal components.
- This information in this document is subject to change without prior notice. For actual design-in, please refer to the latest publications of data sheet, etc., for the most up-to date specifications of the unit.
- No part of this document may be copied or reproduced in any form without prior written consent of Denset-Lambda.

Note : CE MARKING

CE Marking, when applied to a product covered by this handbook, indicates compliance with the low voltage directive.

Table of Contents

■ Block Diagram

■ Sequence Time Chart

■ Terminal Explanation

■ Explanation on Specifications

1. **Input Voltage Range**
2. **Maximum Output Ripple and Noise**
3. **Maximum Line Regulation**
4. **Maximum Load Regulation**
5. **Over Current Protection (OCP)**
6. **Over Voltage Protection (OVP)**
7. **Over Thermal Protection (OTP)**
8. **Parallel Operation**
9. **Series Operation**
10. **Power ON Signal (ENA Terminal)**
11. **Operating Temperature Range**
12. **Operating Humidity**
13. **Storage Temperature**
14. **Storage Humidity**
15. **Cooling Method**
16. **Withstand Voltage**
17. **Insulation Resistance**
18. **Recommended Soldering Condition**

■ Before concluding module damage

Block Diagram

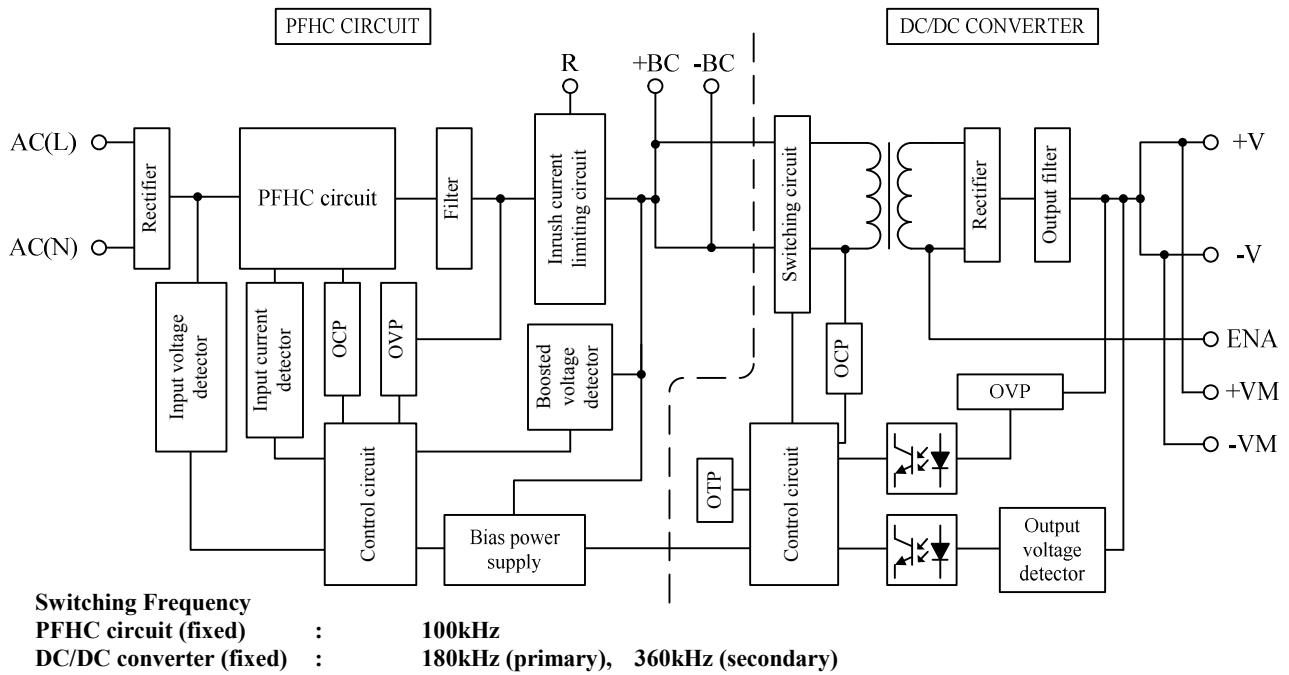

Sequence Time Chart

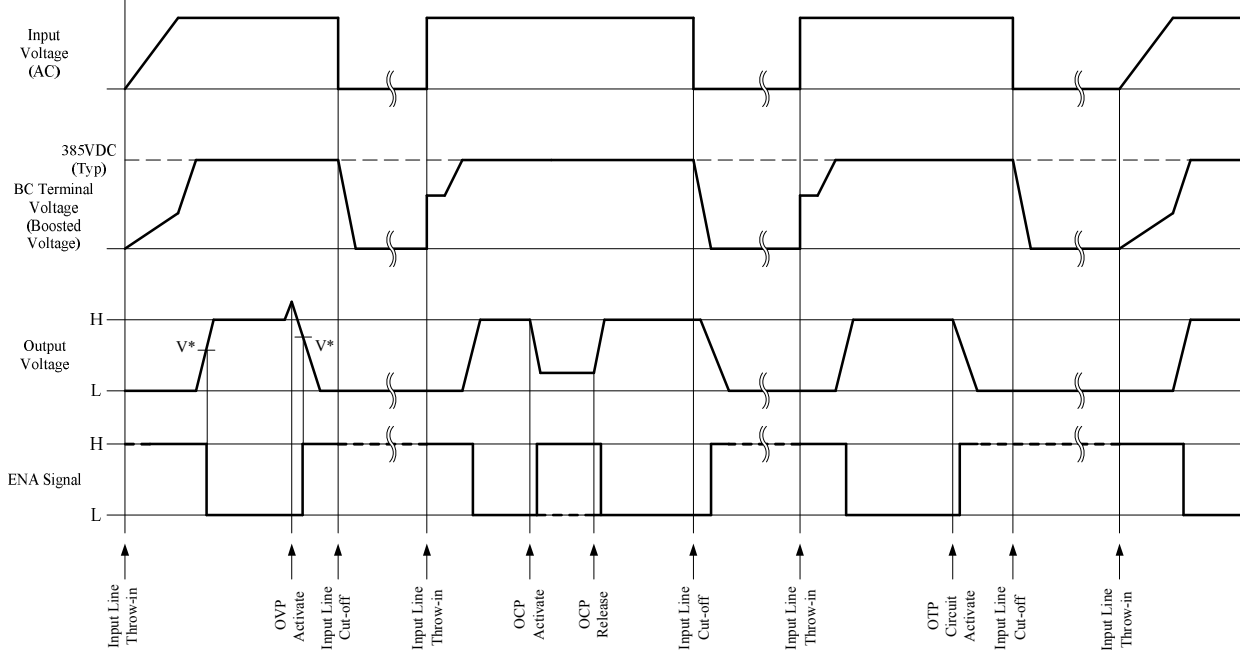

Note : This product has no remote ON/OFF function.

V* voltage level: Refer to Application Notes "10.Power ON Signal (ENA Terminal)" section.

■ Terminal Explanation

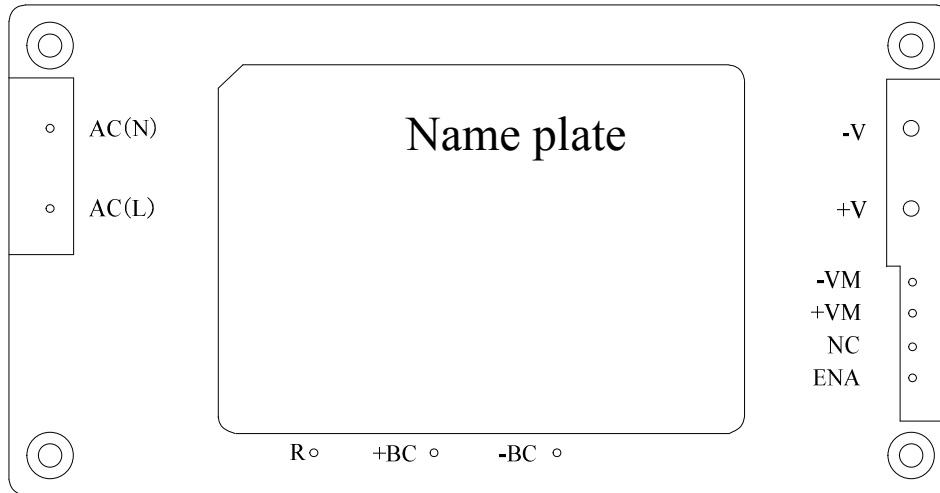

[Input side terminals]
 AC (L) : Input terminal live line
 AC (N) : Input terminal neutral line

+BC : +Boost voltage terminal
 -BC : -Boost voltage terminal
 R : External inrush current limiting resistor

[Output side terminals]
 +V : +Output terminal
 -V : -Output terminal

+VM : +Output monitor terminal
 -VM : -Output monitor terminal
 NC : Make no external connection
 ENA : Power on signal terminal

- Baseplate can be connected to FG through M3 mounting tapped holes.
- Consider contact resistance when connecting AC (L), AC (N), R, +BC, -BC, +V, -V.
- Note that +BC and -BC terminals are primary voltage with high voltage (385VDC).
 Do not connect load from these terminals.
- Do not make external connection to NC terminal.

■ Explanations on Specifications

1. Input Voltage Range

Input voltage range is indicated below. Take care not to apply input voltage which is out of this specified range nor should a DC input voltage be applied as this would result into power module damage.

Input Voltage Range : Single Phase 85 to 265VAC Line Frequency Range : 47 to 63Hz

● Basic Connection

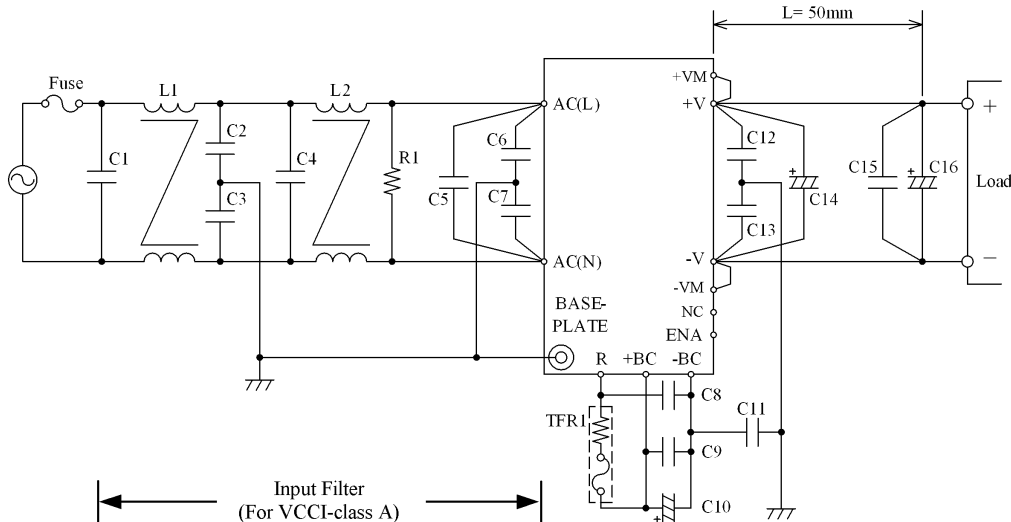

Fig. 1-1 Basic Connection

External Input Fuse

This power module has no internal fuse. Use external fuse to acquire each Safety Standard and to further improve safety. Further, Fast-Blow type fuse must be used per one module. Also, in-rush surge current flows during line throw-in. Be sure to check I^2t rating of external switch and external fuse.

Recommended External Fuse : F15AH, 250V

Note) Select fuse based on rated voltage, rated current and surge current capability.

(1) Voltage Ratings

100VAC line : AC125V

200VAC line : AC250V

(2) Current Ratings

Rated current is determined by the maximum input current based on operating conditions and can be calculated by the following formula.

$$I_{in(max)} = \frac{P_{out}}{V_{in} \times \text{Eff} \times \text{PF}} \quad (\text{Arms}) \quad (\text{Formula 1-1})$$

$I_{in(max)}$: Maximum Input Current
P_{out}	: Maximum Output Power
V_{in}	: Minimum Input Voltage
Eff	: Efficiency
PF	: Power Factor

For Efficiency and Power Factor values, refer to separate document "PFE700S Series Evaluation Data".

C1, C4, C5 : 1uF (Film Capacitor)

Ripple current flows through this capacitor. When selecting capacitor, be sure to check the allowable maximum ripple current rating of this capacitor. Verify the actual ripple current flowing through this capacitor by doing actual measurement.

Recommended Voltage Rating : 250VAC

Note) Connect C5 as close as possible towards the input terminals of this power module.

L1, L2 : 6mH

Add common mode choke coil as EMI/EMS countermeasure. When using multiple modules, connect coil to each module.

Note) Depending on the input filter used, noise might increase or power module might malfunction due to filter resonance.

C2, C3 : 4,700pF (Ceramic Capacitor)

Add ceramic capacitor as EMI/EMS countermeasure. Be sure to consider leakage current of your equipment when adding this capacitor.

High withstand voltage are applied across this capacitor depending on the application. Select capacitors with high withstand voltage rating.

R1 : 470kΩ

Connect bleeder resistor across AC(L) and AC(N) terminals.

C6, C7 : 1000pF (Ceramic Capacitor)

Add ceramic capacitor as EMI/EMS countermeasure. Be sure to consider leakage current of your equipment when adding this capacitor.

High withstand voltage are applied across this capacitor during withstand voltage test depending on the application. Select capacitors with high withstand voltage rating.

Also, connect C6, C7 as close as possible to the terminals.

C8, C9 : 1uF (Film Capacitor)

Ripple current flows through this capacitor. When selecting capacitor, be sure to check the allowable maximum ripple current rating of this capacitor. Verify the actual ripple current flowing through this capacitor by doing actual measurement.

Recommended Voltage Rating : 450VDC

Note) Select Capacitor with more than 3A (rms) rating. Connect C8, C9 as close as possible towards the output terminals of this power module.

**C10: 780uF (390uF x 2 parallel)
(Electrolytic Capacitor)**

Refer to "Selection Method of External Bulk Capacitor for Boost Voltage" below.

Allowable External Capacitance at nominal capacitor value is shown below.

Recommended Voltage Rating : 450VDC

Recommended Total Capacitor : 390uF to 1,200uF

Note) 1. Do not connect capacitors with more than the above capacitance value as this would result into power module damage.
2. When using module below -20 °C ambient temperature, AC ripple of boost voltage, output ripple voltage and start up characteristics might be affected by ESR characteristics of the bulk capacitors. Therefore, be sure to verify characteristics by actual evaluation.

C11 : 1000pF (Ceramic Capacitor)

Add ceramic capacitor as EMI/EMS countermeasure.

High withstand voltage are applied across this capacitor during withstand voltage test depending on the application. Select capacitors with high withstand voltage rating.

Also, connect C11 as close as possible to the terminals.

C12, C13 : 0.033uF

Connect ceramic or film capacitor as EMI/EMS countermeasure and to reduce spike noise.

Note) High Voltage is applied across this capacitor during withstand voltage test depending on the application.

Connect C12, C13 as close as possible towards the output terminals of this power module.

C14 : 220uF

To reduce output ripple noise voltage, connect electrolytic capacitors across +V and -V.

Note) Connect C14 as close as possible to the +V and -V output terminals of this power module.

Recommended Voltage Rating : 100VDC

C15 : 2.2uF

Connect chip ceramic capacitor within 50mm from the output terminals +V and -V of the power module to reduce output spike noise.

Also, note that output spike voltage may vary depending on the wiring pattern of the printed circuit board.

C16 : 220uF

Connect C16 within 50mm from the output terminals +V and -V of the power module to stabilize operation.

Note that the output ripple and line turn off characteristics of the power module might be affected by the ESR and ESL of the electrolytic capacitor.

Also, note that output ripple voltage may vary depending on the wiring pattern of the printed circuit board.

Sudden change in output voltage due to sudden load change or sudden input voltage change can be reduced by increasing external output capacitor value.

Recommended Voltage Rating : 100VDC

Note) 1. Use low-impedance electrolytic capacitors with excellent temperature characteristics.
(Nichicon PM Series or equivalent)
2. For module operation at ambient temperature -20 °C or less, output ripple voltage might be affected by ESR characteristics of the electrolytic capacitors. Increase the capacitor values shown below.

**C14, C16 : 100V 220uF x 2 parallel
(Ambient Temperature < -20°C)**

3. Take note of the maximum allowable ripple current of the electrolytic capacitor used. Especially, for sudden load current changes, verify actual ripple current and make sure that allowable maximum ripple current is not exceeded.

● **Selection Method of External Bulk Capacitor for Boost Voltage**

Boost voltage bulk capacitor is determined by boost voltage ripple voltage, ripple current and hold-up time.

Select capacitor value such that boost voltage ripple voltage does not exceed 15Vp-p.

Note) When ambient temperature is -20°C or less,

Boost voltage might increase due to ESR characteristics. Therefore, verify above characteristics by actual evaluation.

For output hold-up time, refer to separate document "PFE700S Series Evaluation Data" and use appropriate capacitor up to 1,200uF maximum. (It is recommended that verification should be done through actual evaluation).

For allowable ripple current value, refer to Fig. 1-2 and select a capacitor with higher ripple current rating.

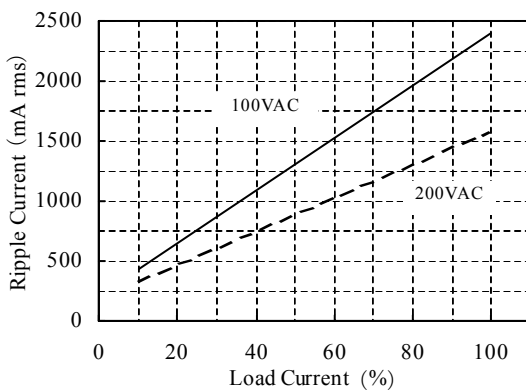

Fig. 1-2 Allowable ripple current value

The recommended boost voltage bulk capacitor value range is 390uF-1200uF.

When using with reduced the bulk capacitor value, it is necessary to reduce output power as shown in Fig1-3.

Note that reducing the bulk capacitance affects output hold-up time, dynamic line response and dynamic load response characteristics.

It is recommended that verification should be done through actual evaluation.

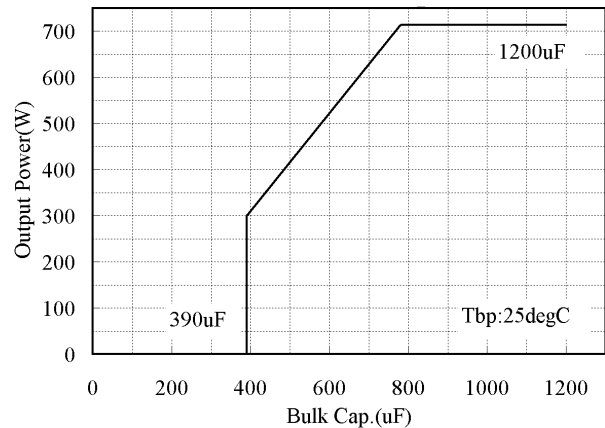

Fig. 1-3

Output Power v.s. Boost Voltage Bulk Capacitance

TFR1 : 10 to 100 Ω

By connecting thermal fuse resistor across R and +BC terminals as shown in Fig. 1-1, in-rush current during line throw-in can be suppressed. Failures due to in-rush current such as melting of external fuse, welding of relay or switch connecting joints or shutdown of No-Fuse Breakers (NFB) might occur. Therefore, be sure to connect this external thermal fuse resistor.

Note that this module will not operate without this external resistor.

● **Selection Method of External Resistor**

(1) Calculating Resistance Value for TFR1

Resistance can be calculated by the formula below.

$$R = \frac{V_{in}}{I_{rush}} \quad (\Omega) \quad (\text{Formula 1-2})$$

R : Resistance Value for External TFR1
 Vin : Input Voltage converted to DC value
 = Input Voltage (rms) x $\sqrt{2}$
 Irush : Input surge current value

(2) Required Surge Current Rating

Sufficient surge current withstand capability is required for external TFR1. Required Surge Current Rating can be selected by I^2t . (Current squared multiplied by time)

$$I^2t = \frac{C_o \times V_{in}^2}{2 \times R} \quad (A^2s) \quad (\text{Formula 1-3})$$

I^2t : Current-squared multiplied by time
 Co : Boost Voltage Bulk Capacitance
 Vin : Input Voltage converted to DC value
 = Input Voltage (rms) x $\sqrt{2}$
 R : Resistance Value for External TFR1

2. Maximum Ripple and Noise

This value is measured according to the description below in accordance with JEITA-9131A (Section 7.12 and Section 7.13).

In the basic connection shown in Fig. 1-1, additional connection shown in Fig. 2-1 is done for measurement. Capacitor (Ceramic Capacitor 2.2uF and Electrolytic Capacitor : 220uF) must be connected within 50mm from the output terminals. Then, connect coaxial cable with JEITA attachment across the ceramic capacitor electrodes. Use 100MHz bandwidth oscillo-scope or equivalent.

Also, note that output ripple voltage and output spike noise may vary depending on the wiring pattern of the printed circuit board.

In general, output ripple voltage and output spike noise can be reduced by increasing external capacitor value.

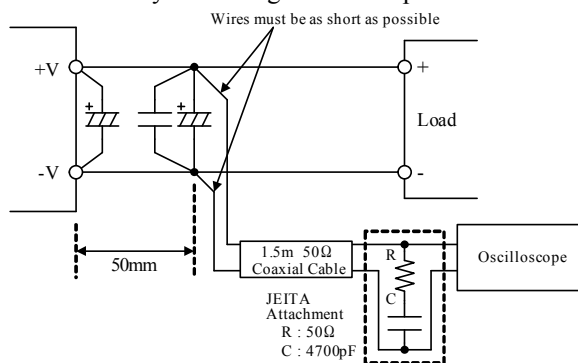

Fig. 2-1
Output Ripple Voltage (including Spike Noise)
Measurement Method

3. Maximum Line Regulation

Maximum line regulation is defined as the maximum output voltage change when input voltage is gradually changed (Steady-State) within specification range.

4. Maximum Load Regulation

Maximum load regulation is defined as the maximum output voltage change when output load current is gradually changed (Steady-State) within specification range.

When using power module in dynamic load mode, audible sound could be heard from the power module or large output voltage change can occur. Make prior evaluation thoroughly before using this power module.

5. Over Current Protection (OCP)

This module is equipped with OCP function.

Output will automatically recover when short circuit or overload condition is removed. OCP value is fixed and cannot be adjusted externally.

Note that continuous short circuit or overload condition might result in power module damage.

6. Over Voltage Protection (OVP)

This module is equipped with OVP function. This value is set between 60.0V to 69.6V.

When the OVP function activates, first cut off input line and verify that boost voltage has dropped down to 20V or less. Then, recover output by recycling input line.

OVP value is fixed and cannot be set externally.

7. Over Temperature Protection (OTP)

This module is equipped with OTP function. This function will activate and shut down the output when ambient temperature or internal temperature abnormally rises. OTP activates at following baseplate temperature.

OTP operate temperature : 105 to 130°C

When OTP function operates, output can be recovered by cooling down the baseplate sufficiently and letting the boost voltage drop down to 20V or less before recycling the input line.

8. Parallel Operation

Output current share parallel operation is possible for PFE700S Series by connecting the output terminal of each power module. Verify the allowable maximum total output current by actual evaluation such that maximum output current rating of each module is not exceeded.

Consult us for details when using PFE700S Series at parallel operation.

9. Series Operation

Series operation is possible for PFE700S Series. Connections shown in Fig. 9-1 and Fig. 9-2 are possible.

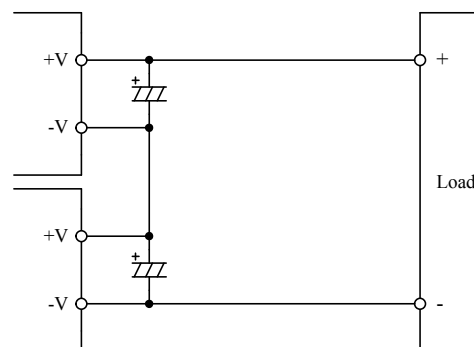

Fig. 9-1 Series Operation for
High Output Voltage Applications

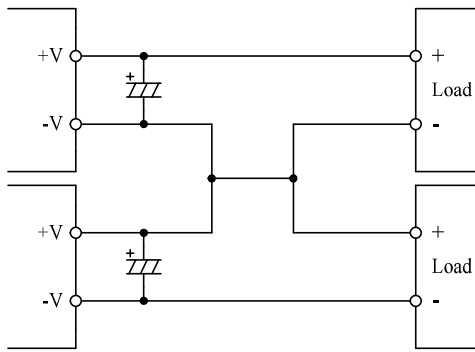

Fig. 9-2 +/--Output Series Applications

10. Power ON Signal (ENA Terminal)

This signal is located at the secondary side (output side) and is an open collector output.

(Maximum sink current is 10mA and maximum applied voltage is 75V.)

When output voltage goes over 46V(TYP) at start up, Power ON signal is “Low level”.

On the other hand, output voltage threshold level for Power ON signal to turn “High level” at shutdown varies according to output condition.

Therefore, be sure to do actual verification.

11. Operating Temperature Range

These products can be used in any orientation but be sure to consider enough airflow to avoid heat accumulation around the module. Consider surrounding components layout and set the PCB mounting direction such that air can flow through the heatsink by forced or convection cooling.

This product can operate at actual mounting condition when baseplate temperature is maintained at or below the 100°C.

Verify baseplate temperature at worst case operating condition at the measuring point shown in Fig. 11-1.

For Thermal Design details, refer to Application Notes “Thermal Design” section.

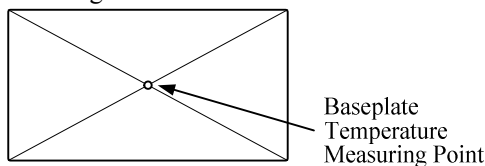

Fig. 11-1 Baseplate Measuring Point

Baseplate temperature range is limited according to Fig. 11-2.

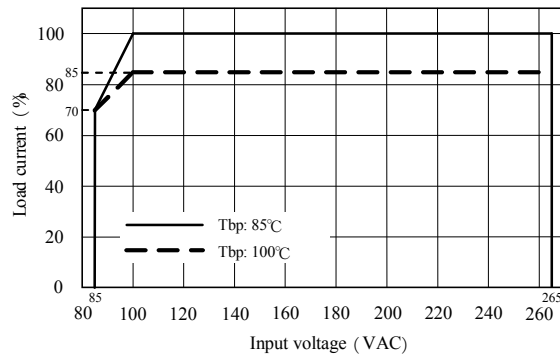
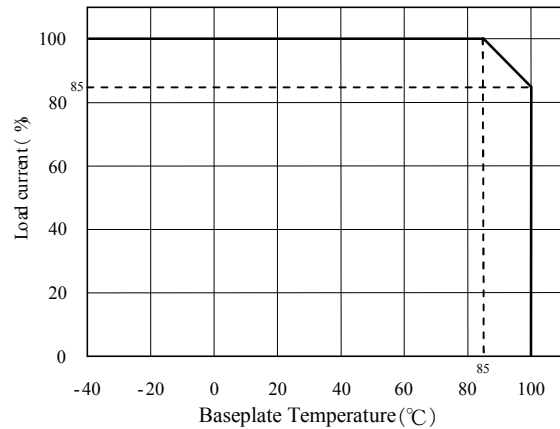

Fig. 11-2 Derating Curve

To further improve the reliability, it is recommended to use this module with baseplate temperature derating.

12. Operating Humidity

Note that dewdrop might cause power module abnormal operation or damage.

13. Storage Temperature

Note that rapid temperature change causes dewdrop causing harmful effect on soldering condition of the terminal pins.

14. Storage Humidity

Storage under high temperature and high humidity causes rust on terminal pins that causes deterioration of soldering conditions. Take enough caution when storing this module.

15. Cooling Method

For details of thermal design, refer to Application Notes “Thermal Design” section.

16. Withstand Voltage

This module is designed to withstand applied voltage 2.5kVAC between input and baseplate, 3kVAC between input and output for a duration of 1 minute. When doing this test during incoming inspection, set the current limit of test equipment to 20mA.

This module is designed to withstand applied voltage 1.5kVDC between output and baseplate for 1 minute. When doing this test during incoming inspection, be sure to apply DC voltage only. Avoid applying AC voltage during this test because this will damage the module.

Refrain from injecting high test voltage suddenly. Be sure to gradually increase the applied withstand voltage during testing and gradually reduce the voltage after the test.

Especially, when using timer switch of the test equipment, impulse voltage which is higher than the applied set voltage, is generated when the timer switch is cut off. This causes damage to the power module. Connect each terminal according to the circuit diagram shown below.

For basic connection shown in Fig. 1-1, do the same terminal connections.

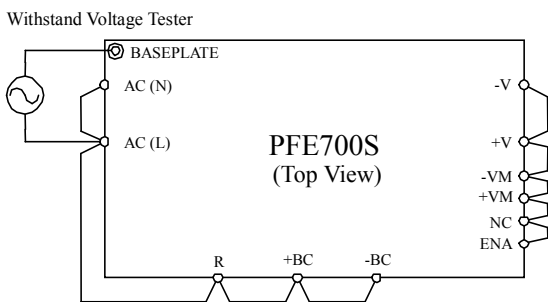

2.5kVAC 1 minute (20mA)

Fig. 16-1 Input to Baseplate Withstand Voltage Test Method

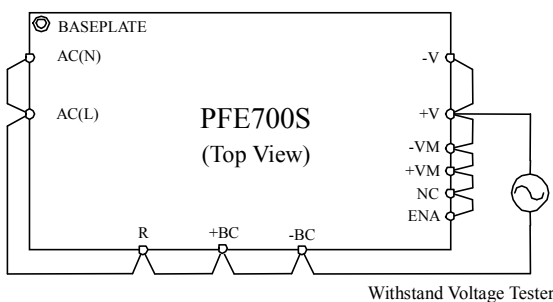

3kVAC 1 minute (20mA)

Fig.16-2 Input to Output Withstand Voltage Test Method

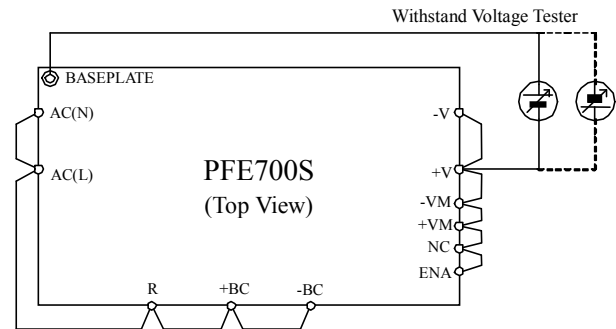

1.5kVDC 1 minute

Fig.16-3 Output to Baseplate Withstand Voltage Test Method

17. Insulation Resistance

Use DC Insulation Resistance test equipment (MAX.500V) between output and baseplate.

Insulation Resistance must be 100M Ω or more at 500VDC. Take caution that some types of test equipment generate high pulse voltage when switching applied voltage. After test, discharge this module using resistor, etc.

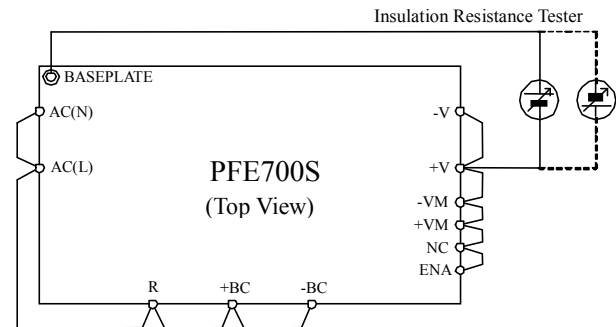

100M Ω or more at 500VDC

Fig. 17-1 Insulation Resistance Test Method

18. Recommended Soldering Condition

Recommended soldering temperature is as follows.

(1) Soldering Dip:

260°C, within 10 seconds

Preheat:

130°C, within 60 seconds

(2) Soldering Iron:

350°C, within 3 seconds

■ Before Concluding Power Module Damage

Verify following items before concluding power module damage.

1) No output voltage

- Is specified input voltage applied?
- Is there no abnormality with the output load?
- Is the actual baseplate temperature within the specified operating temperature of this module?

2) Output voltage is low

- Is specified input voltage applied?
- Is there no abnormality with the output load?

3) Load regulation or line regulation is large

- Is specified input voltage applied?
- Are the input or output terminals firmly connected?
- Are the input and output wires too thin?

4) Large output ripple

- Is the measurement done according to methods described Application Notes or is it an equivalent method?