

Excellent Integrated System Limited

Stocking Distributor

Click to view price, real time Inventory, Delivery & Lifecycle Information:

[IXYS Corporation](#)

[DGS15-018CS](#)

For any questions, you can email us directly:



sales@integrated-circuit.com

	DGS 15-018CS DGSK 32-018CS
---	---

Gallium Arsenide Schottky Rectifier

Second generation

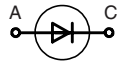
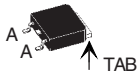
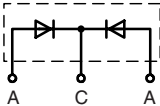
$V_{RRM} = 180\text{ V}$
 $I_{DC} = 24\text{ A}$
 $C_{Junction} = 21\text{ pF}$

Type	Marking on product	Circuit	Package
DGS 15-018CS	15A180AS	Single 	TO-252 AA 
DGSK 32-018CS	DGSK 32-018CS	Common cathode 	TO-263 AB  A = Anode, TAB = Cathode

Diode		
Symbol	Conditions	Maximum Ratings
$V_{RRM/RSM}$		180 V
I_{FAV}	$T_C = 25^\circ\text{C}; \text{DC}$	24 A
I_{FAV}	$T_C = 90^\circ\text{C}; \text{DC}$	15 A
I_{FSM}	$T_{VJ} = 45^\circ\text{C}; t_p = 10\text{ ms (50 Hz), sine}$	80 A
P_{tot}	$T_C = 25^\circ\text{C}$	34 W

Symbol	Conditions	Characteristic Values		
		min.	typ.	max.
V_F	$I_F = 7.5\text{ A}; T_{VJ} = 25^\circ\text{C}$ $I_F = 7.5\text{ A}; T_{VJ} = 125^\circ\text{C}$	1.25	1.5	V
I_R	$V_R = V_{RRM}; T_{VJ} = 25^\circ\text{C}$ $V_R = V_{RRM}; T_{VJ} = 125^\circ\text{C}$	0.25	0.25	mA
I_{RM} t_{rr}	$I_F = 5\text{ A}; -di_F/dt = 150\text{ A}/\mu\text{s};$ $V_R = 100\text{ V}; T_{VJ} = 125^\circ\text{C}$	1.1	23	A ns
C_J	$V_R = 100\text{ V}; T_{VJ} = 125^\circ\text{C}$	21		pF
R_{thJC}			4.4	K/W

Data according to IEC 60747 and per diode unless otherwise specified

Component		
Symbol	Conditions	Maximum Ratings
T_{VJ}		-55...+175 °C
T_{stg}		-55...+150 °C

Symbol	Conditions	Characteristic Values		
		min.	typ.	max.
Weight	TO-252	0.3		g
	TO-263	2		g

Features

GaAs Schottky Diode with Enhanced Barrier Height:

- lowest operating forward voltage drop due to additional injection of minority carriers
- high switching speed
- low junction capacity of GaAs diode independent from temperature
- short and low reverse recovery current peak due to short lifetime of minority carriers
- soft turn off

Surface Mount Packages:

- Incorporating Single and Dual Diode Topologies
- Industry Standard Package Outlines
- Epoxy meets UL 94V-0

Applications

Switched Mode Power Supplies:

- AC-DC converters
 - DC-DC converters
- with:*
- high switching frequency
 - high efficiency
 - low EMI
- for use e. g. in:*
- telecom
 - computer
 - automotive equipment

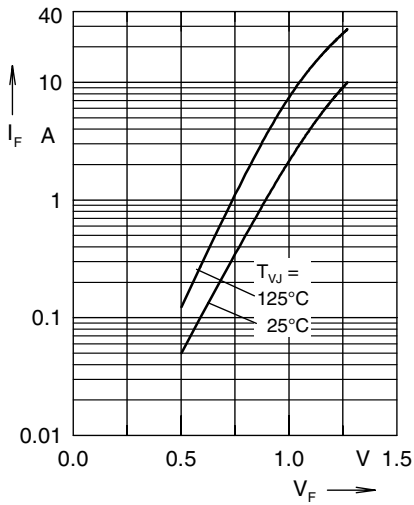

Fig. 1 typ. forward characteristics

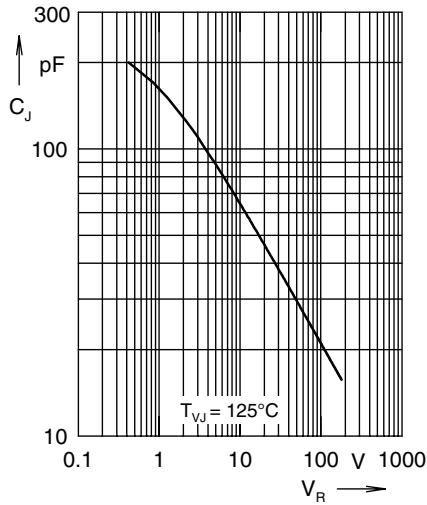

Fig. 2 typ. junction capacity versus blocking voltage

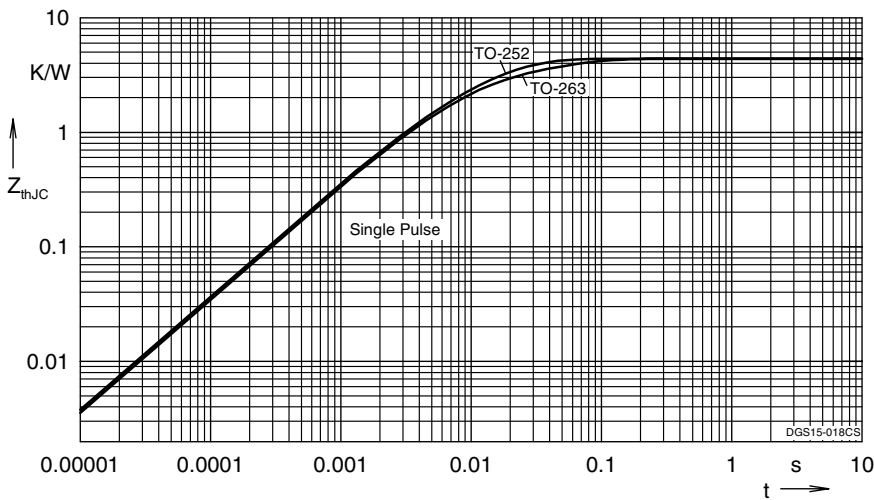
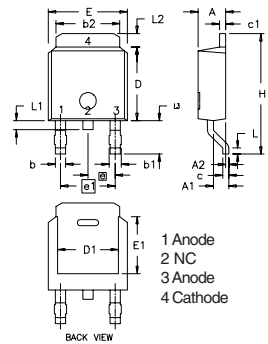

Fig. 3 typ. thermal impedance junction to case

Outlines TO-252 AA



Dim.	Millimeter		Inches	
	Min.	Max.	Min.	Max.
A	2.19	2.38	0.086	0.094
A1	0.89	1.14	0.035	0.045
A2	0	0.13	0	0.005
b	0.64	0.89	0.025	0.035
b1	0.76	1.14	0.030	0.045
b2	5.21	5.46	0.205	0.215
c	0.46	0.58	0.018	0.023
c1	0.46	0.58	0.018	0.023
D	5.97	6.22	0.235	0.245
D1	4.32	5.21	0.170	0.205
E	6.35	6.73	0.250	0.265
E1	4.32	5.21	0.170	0.205
e	2.28 BSC		0.090 BSC	
e1	4.57 BSC		0.180 BSC	
H	9.40	10.42	0.370	0.410
L	0.51	1.02	0.020	0.040
L1	0.64	1.02	0.025	0.040
L2	0.89	1.27	0.035	0.050
L3	2.54	2.92	0.100	0.115

Outlines TO-263 AB

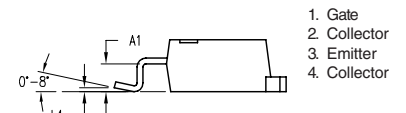
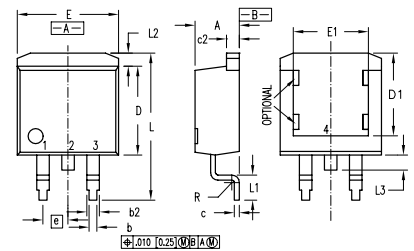

Dim.	Millimeter		Inches	
	Min.	Max.	Min.	Max.
A	4.06	4.83	.160	.190
A1	2.03	2.79	.080	.110
b	0.51	0.99	.020	.039
b2	1.14	1.40	.045	.055
c	0.46	0.74	.018	.029
c2	1.14	1.40	.045	.055
D	8.64	9.65	.340	.380
D1	8.00	8.89	.315	.350
E	9.65	10.29	.380	.405
E1	6.22	8.13	.245	.320
e	2.54 BSC		.100 BSC	
L	14.61	15.88	.575	.625
L1	2.29	2.79	.090	.110
L2	1.02	1.40	.040	.055
L3	1.27	1.78	.050	.070
L4	0	0.20	0	.008
R	0.46	0.74	.018	.029