

Excellent Integrated System Limited

Stocking Distributor

Click to view price, real time Inventory, Delivery & Lifecycle Information:

[IXYS Corporation](#)

[DSEP30-12CR](#)

For any questions, you can email us directly:

sales@integrated-circuit.com

DSEP30-12CR

HiPerDynFRED

High Performance Dynamic Fast Recovery Diode
 Extreme Low Loss and Soft Recovery
 Single Diode

Part number

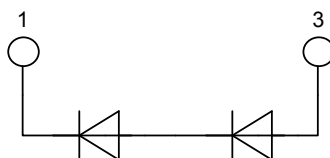
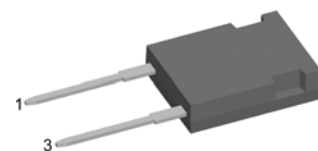
DSEP30-12CR

 $V_{RRM} = 1200\text{ V}$
 $I_{FAV} = 30\text{ A}$
 $t_{rr} = 15\text{ ns}$

Backside: isolated

Features / Advantages:

- Planar passivated chips
- Very low leakage current
- Very short recovery time
- Improved thermal behaviour
- Very low I_{rm} -values
- Very soft recovery behaviour
- Soft reverse recovery for low EMI/RFI
- Low I_{rm} reduces:
 - Power dissipation within the diode
 - Turn-on loss in the commutating switch

Applications:

- Antiparallel diode for high frequency switching devices
- Antisaturation diode
- Snubber diode
- Free wheeling diode
- Rectifiers in switch mode power supplies (SMPS)
- Uninterruptible power supplies (UPS)

Package:

- Housing: ISOPLUS247
- Industry standard outline
- DCB isolated backside
- Isolation Voltage 3000 V
- Epoxy meets UL 94V-0
- RoHS compliant

 Ratings

Symbol	Definition	Conditions	min.	typ.	max.	Unit	
V_{RRM}	max. repetitive reverse voltage	$T_{VJ} = 25^\circ\text{C}$			1200	V	
I_R	reverse current	$V_R = 1200\text{ V}$			250	μA	
		$V_R = 1200\text{ V}$			2	mA	
V_F	forward voltage	$I_F = 30\text{ A}$			4.98	V	
		$I_F = 60\text{ A}$			6.33	V	
		$I_F = 30\text{ A}$	$T_{VJ} = 150^\circ\text{C}$			3.18	V
		$I_F = 60\text{ A}$	$T_{VJ} = 150^\circ\text{C}$			4.40	V
I_{FAV}	average forward current	rectangular $d = 0.5$			30	A	
V_{F0}	threshold voltage	$T_{VJ} = 175^\circ\text{C}$			1.42	V	
r_F	slope resistance				24.4	m Ω	
R_{thJC}	thermal resistance junction to case				0.60	K/W	
T_{VJ}	virtual junction temperature		-55		175	$^\circ\text{C}$	
P_{tot}	total power dissipation	$T_C = 25^\circ\text{C}$			250	W	
I_{FSM}	max. forward surge current	$t = 10\text{ ms}$ (50 Hz), sine			250	A	
I_{RM}	max. reverse recovery current				5.5	A	
		$I_F = 30\text{ A}; V_R = 600\text{ V}$			12.5	A	
		$-di_F/dt = 600\text{ A}/\mu\text{s}$			15	ns	
t_{rr}	reverse recovery time	$T_{VJ} = 25^\circ\text{C}$			70	ns	
		$T_{VJ} = 100^\circ\text{C}$					
C_J	junction capacitance	$V_R = 800\text{ V}; f = 1\text{ MHz}$			13	pF	



DSEP30-12CR

Symbol	Definition	Conditions	Ratings			Unit
			min.	typ.	max.	
I_{RMS}	RMS current	per terminal			70	A
R_{thCH}	thermal resistance case to heatsink			0.25		K/W
T_{stg}	storage temperature		-55		150	°C
Weight				6		g
F_C	mounting force with clip		20		120	N
V_{ISOL}	isolation voltage	t = 1 second	3600			V
		t = 1 minute	3000			V
$d_{Spp/App}$	creepage striking distance on surface through air	terminal to terminal	5.5			mm
$d_{Spb/Apb}$	creepage striking distance on surface through air	terminal to backside	5.5			mm

Product Marking

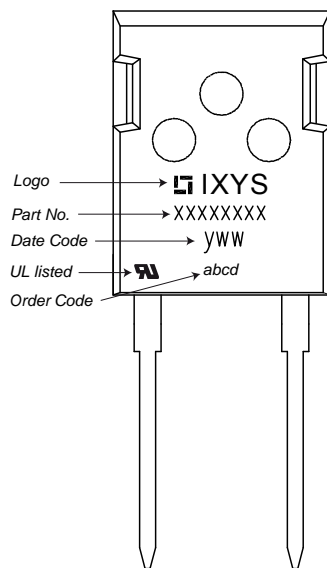

Ordering	Part Name	Marking on Product	Delivering Mode	Base Qty	Code Key
Standard	DSEP30-12CR	DSEP30-12CR	Tube	30	481955

Similar Part	Package	Voltage Class
DSEP30-12A	TO-247AD (2)	1200
DSEP29-12A	TO-220AC (2)	1200
DSEP30-12AR	ISOPLUS247 (2)	1200
DHG30I1200HA	TO-247AD (2)	1200

Outlines ISOPLUS247

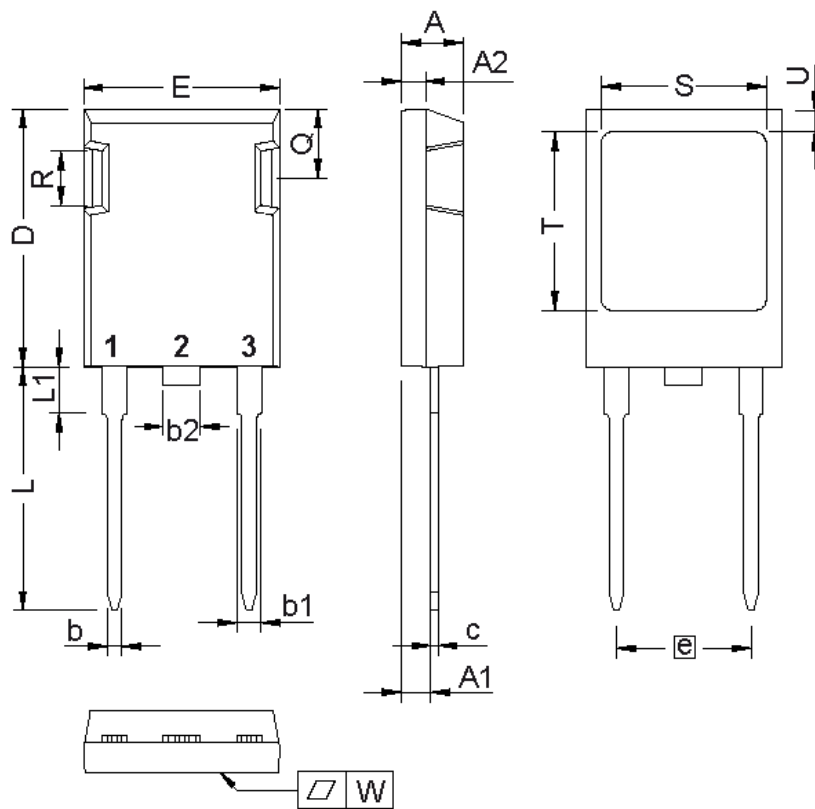

Dim.	Millimeter		Inches	
	min	max	min	max
A	4.83	5.21	0.190	0.205
A1	2.29	2.54	0.090	0.100
A2	1.91	2.16	0.075	0.085
b	1.14	1.40	0.045	0.055
b1	1.91	2.15	0.075	0.085
b2	2.92	3.20	0.115	0.126
c	0.61	0.83	0.024	0.033
D	20.80	21.34	0.819	0.840
E	15.75	16.13	0.620	0.635
e	10.90 BSC		0.430 BSC	
L	19.81	20.60	0.780	0.811
L1	3.81	4.38	0.150	0.172
L2	0.00	2.54	0.000	0.100
Q	5.59	6.20	0.220	0.244
R	4.32	4.85	0.170	0.191
S	13.21	13.72	0.520	0.540
T	15.75	16.26	0.620	0.640
U	1.65	2.03	0.065	0.080
W	-	0.10	-	0.004

Die konvexe Form des Substrates ist typ. < 0.04 mm über der Kunststoffoberfläche der Bauteilunterseite
The convex bow of substrate is typ. < 0.04 mm over plastic surface level of device bottom side

Die Gehäuseabmessungen entsprechen dem Typ TO-247 AD gemäß JEDEC außer Schraubloch und L_{max}.
This drawing will meet all dimensions requirement of JEDEC outline TO-247 AD except screw hole and except L_{max}.

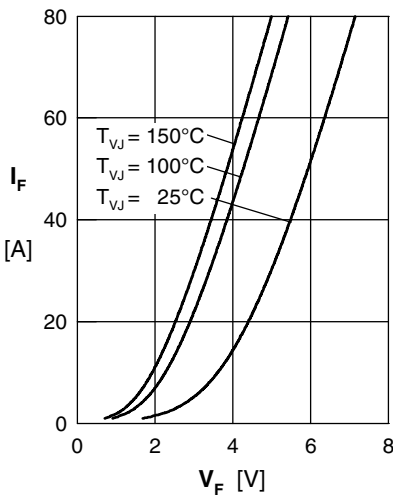

Fig. 1 Forward current I_F vs. V_F

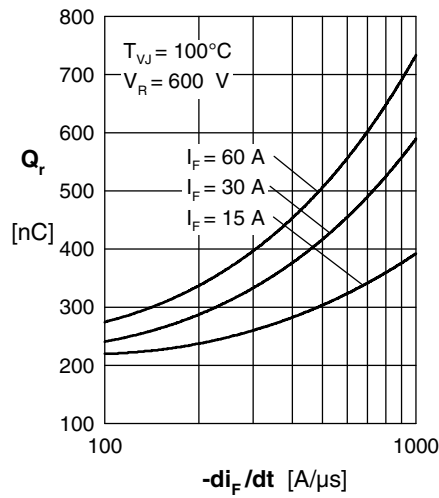

Fig. 2 Reverse recovery charge Q_r versus $-di_F/dt$

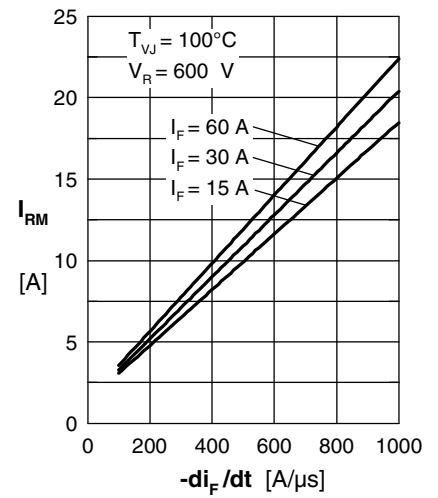

Fig. 3 Peak reverse current I_{RM} versus $-di_F/dt$

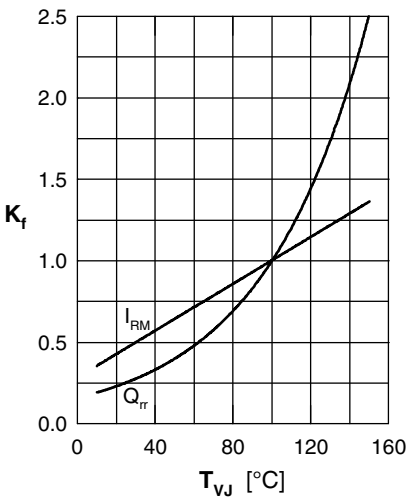

Fig. 4 Dynamic parameters Q_r , I_{RM} versus T_{VJ}

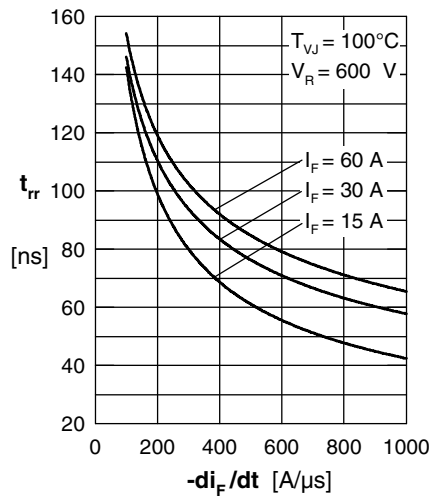

Fig. 5 Recovery time t_{tr} versus $-di_F/dt$

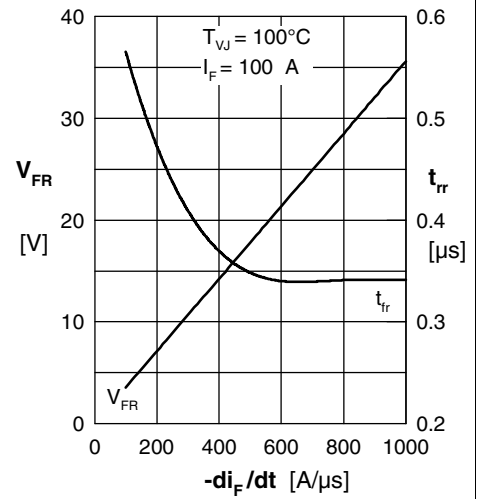

Fig. 6 Peak forward voltage V_{FR} and t_{tr} versus di_F/dt

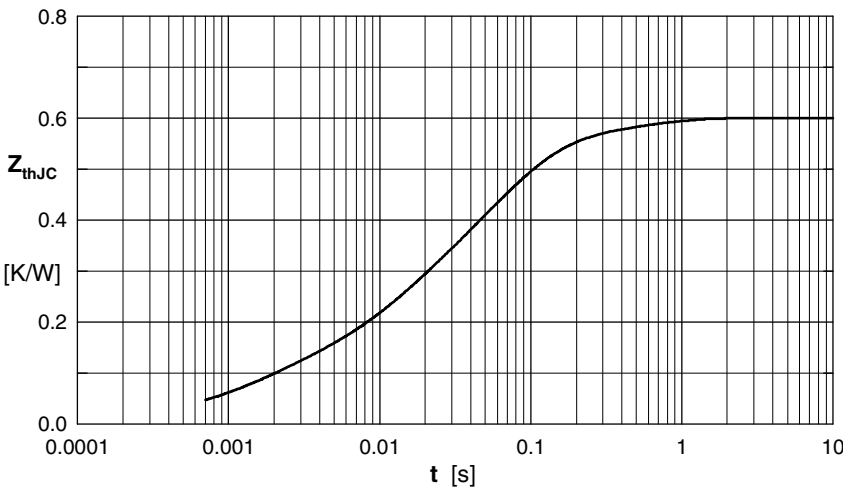

Fig. 7 Transient thermal resistance junction to case

Constants for Z_{thJC} calculation:

i	R_{thi} (K/W)	t_i (s)
1	0.08	0.0013
2	0.122	0.0097
3	0.116	0.037
4	0.23	0.07
5	0.052	0.45