

Excellent Integrated System Limited

Stocking Distributor

Click to view price, real time Inventory, Delivery & Lifecycle Information:

[IXYS Corporation](#)

[IXGQ85N33PCD1](#)

For any questions, you can email us directly:

sales@integrated-circuit.com



Advance Technical Information

Polar™ High Speed IGBT
with Anti-Parallel Diode
for PDP Sustain Circuit

IXGQ85N33PCD1

$$V_{CES} = 330 \text{ V}$$

$$I_{CP} = 340 \text{ A}$$

$$V_{CE(sat)} \leq 2.1 \text{ V}$$

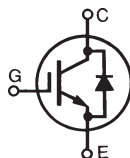

Symbol	Test Conditions	Maximum Ratings	
V_{CES}	$T_J = 25^\circ\text{C to } 150^\circ\text{C}$	330	V
V_{GEM}		± 30	V
I_{C25}	$T_C = 25^\circ\text{C}$, IGBT chip capability	85	A
I_{CP}	$T_J \leq 150^\circ\text{C}$, $t_p \leq 1 \mu\text{s}$, $D \leq 1\%$	340	A
I_{DP}	$T_J \leq 150^\circ\text{C}$, $t_p < 10 \mu\text{s}$	40	A
$I_{C(RMS)}$	Lead current limit	75	A
SSOA (RBSOA)	$V_{GE} = 15 \text{ V}$, $T_{VJ} = 150^\circ\text{C}$, $R_G = 20 \Omega$ Clamped inductive load, $V_{CE} < 300 \text{ V}$	$I_{CM} = 96$	A
P_c	$T_C = 25^\circ\text{C}$	150	W
T_J		-55 ... +150	$^\circ\text{C}$
T_{JM}		150	$^\circ\text{C}$
T_{stg}		-55 ... +150	$^\circ\text{C}$
	Maximum lead temperature for soldering 1.6 mm (0.062 in.) from case for 10 s	300	$^\circ\text{C}$
	Plastic body	260	
M_d	Mounting torque	1.3/10	Nm/lb.in.
Weight		5.5	g

TO-3P

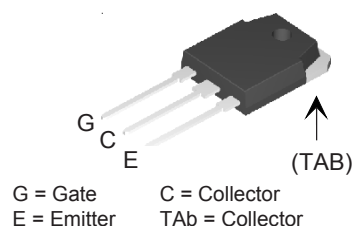
Features

- International standard package
- Fast t_{fi} for minimum turn off switching losses
- MOS Gate turn-on - drive simplicity
- Positive dV_{sat}/dt for paralleling

 \leq

Symbol	Test Conditions ($T_J = 25^\circ\text{C}$ unless otherwise specified)	Characteristic Values		
		Min.	Typ.	Max.
$V_{GE(th)}$	$I_C = 1 \text{ mA}$, $V_{CE} = V_{GE}$	3.0		6.0 V
I_{CES}	$V_{CE} = 330 \text{ V}$			1 μA
	$V_{GE} = 0 \text{ V}$		$T_J = 125^\circ\text{C}$	200 μA
I_{GES}	$V_{CE} = 0 \text{ V}$, $V_{GE} = \pm 20 \text{ V}$			$\pm 100 \text{ nA}$
$V_{CE(sat)}$	$V_{GE} = 15 \text{ V}$, Note 1	$I_C = 50 \text{ A}$		1.43 2.1 V
			$T_J = 125^\circ\text{C}$	1.47 V
		$I_C = 100 \text{ A}$		1.85 3.0 V
			$T_J = 125^\circ\text{C}$	2.0 V

Symbol		Test Conditions	Characteristic Values		
		($T_J = 25^\circ\text{C}$ unless otherwise specified)	Min.	Typ.	Max.
g_{fs}		$I_C = 43\text{ A}, V_{CE} = 10\text{ V}$	30	49	S
C_{ies}	}	$V_{CE} = 25\text{ V}, V_{GE} = 0\text{ V}, f = 1\text{ MHz}$		2200	pF
C_{oes}				155	pF
C_{res}				25	pF
Q_g	}	$I_C = 43\text{ A}, V_{GE} = 15\text{ V}, V_{CE} = 0.5 V_{CES}$		80	nC
Q_{ge}				15	nC
Q_{gc}				23	nC
$t_{d(on)}$	}	Resistive load, $T_J = 25^\circ\text{C}$ $I_C = 50\text{ A}, V_{GE} = 15\text{ V}$ $V_{CE} = 240\text{ V}, R_G = 5\ \Omega$		20	ns
t_{ri}				43	ns
$t_{d(off)}$				87	ns
t_{fi}				72	350
$t_{d(on)}$	}	Resistive load, $T_J = 125^\circ\text{C}$ $I_C = 50\text{ A}, V_{GE} = 15\text{ V}$ $V_{CE} = 240\text{ V}, R_G = 5\ \Omega$		20	ns
t_{ri}				95	ns
$t_{d(off)}$				88	ns
t_{fi}				130	ns
R_{thJC}					0.833 K/W
R_{thCK}			0.25		K/W

Reverse Diode		Characteristic Values		
		$(T_J = 25^\circ\text{C}$ unless otherwise specified)		
Symbol	Test Conditions	Min.	Typ.	Max.
V_F	$I_F = 20\text{ A}, V_{GE} = 0\text{ V}$, Note 1			2.0 V
	$I_F = 40\text{ A}, V_{GE} = 0\text{ V}$, Note 1			2.8 V
R_{thJC}				2.5 K/W
t_{rr}				250 ns

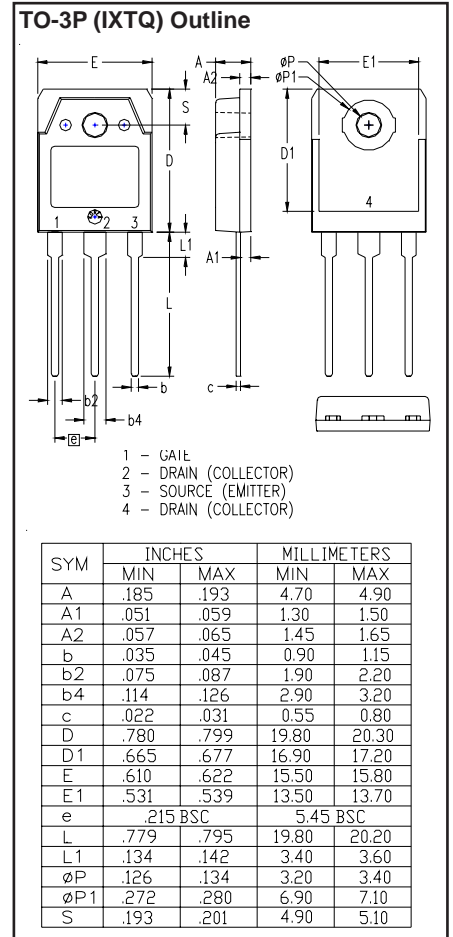
 Note 1: Pulse test, $t \leq 300\ \mu\text{s}$, duty cycle $\leq 2\%$

IXYS reserves the right to change limits, test conditions and dimensions.

 IXYS MOSFETs and IGBTs are covered by one or more of the following U.S. patents:

4,835,592	4,931,844	5,049,961	5,237,481	6,162,665	6,404,065 B1	6,683,344	6,727,585	7,005,734 B2	7,157,338 B2
4,850,072	5,017,508	5,063,307	5,381,025	6,259,123 B1	6,534,343	6,710,405 B2	6,759,692	7,063,975 B2	
4,881,106	5,034,796	5,187,117	5,486,715	6,306,728 B1	6,583,505	6,710,463	6,771,478 B2	7,071,537	

Fig. 1. Output Characteristics @ 25 °C

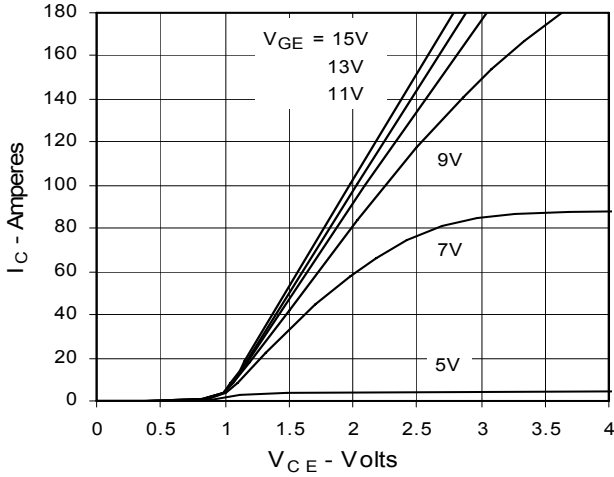

Fig. 2. Extended Output Characteristics @ 25 °C

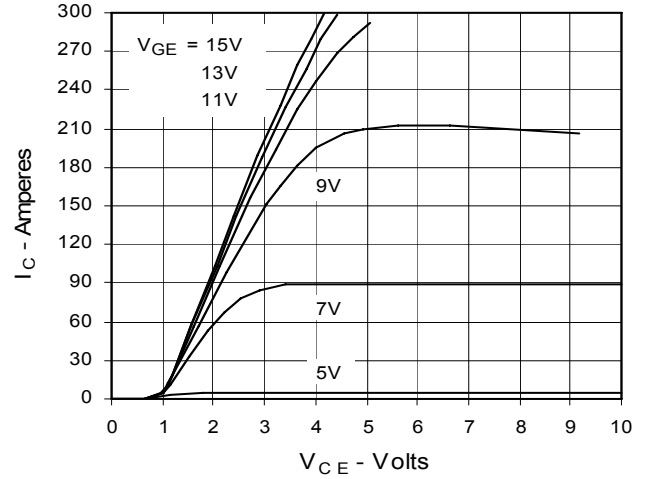

Fig. 3. Output Characteristics @ 125 °C

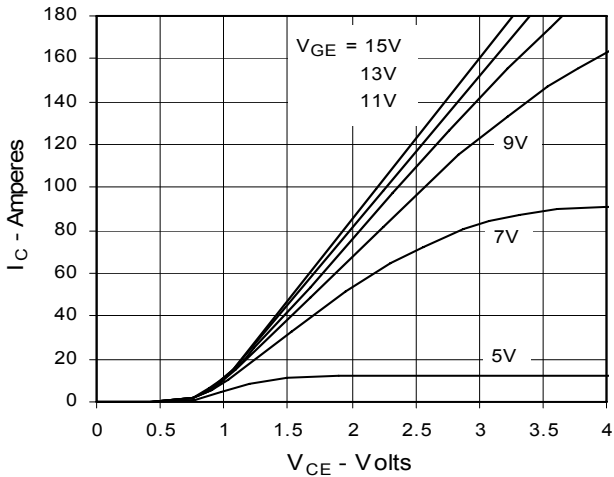

Fig. 4. Dependence of $V_{CE(sat)}$ on Temperature

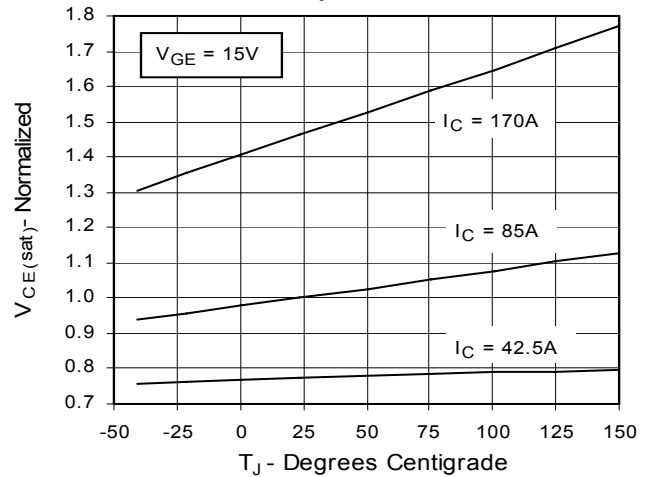

Fig. 5. Collector-to-Emitter Voltage vs. Gate-to-Emitter voltage

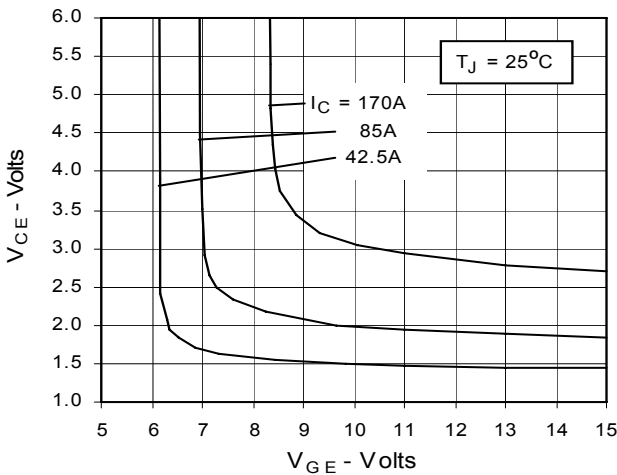

Fig. 6. Input Admittance

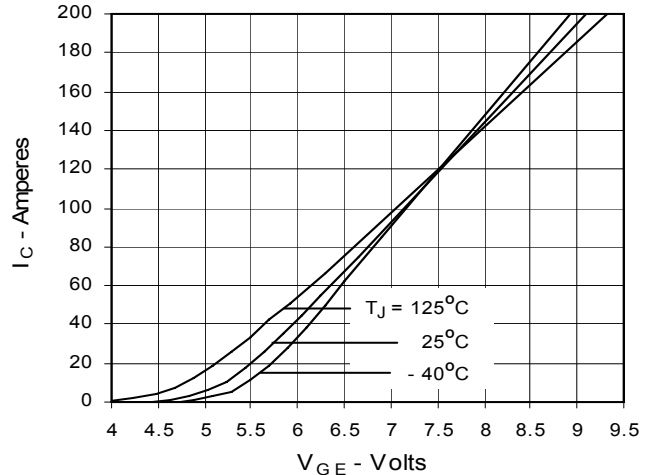

Fig. 7. Transconductance

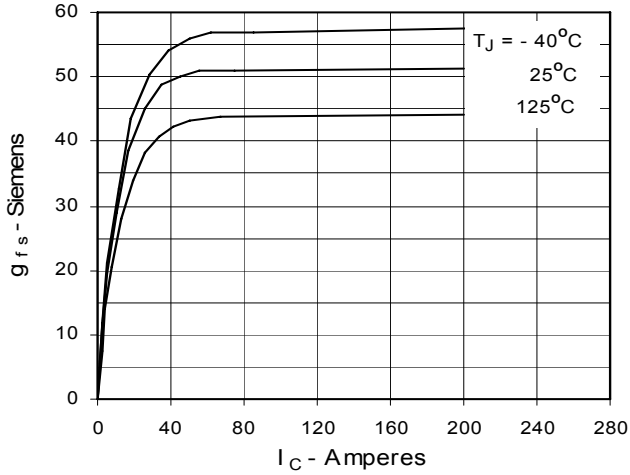

Fig. 8. Resistive Turn-On Rise Time vs. Junction Temperature

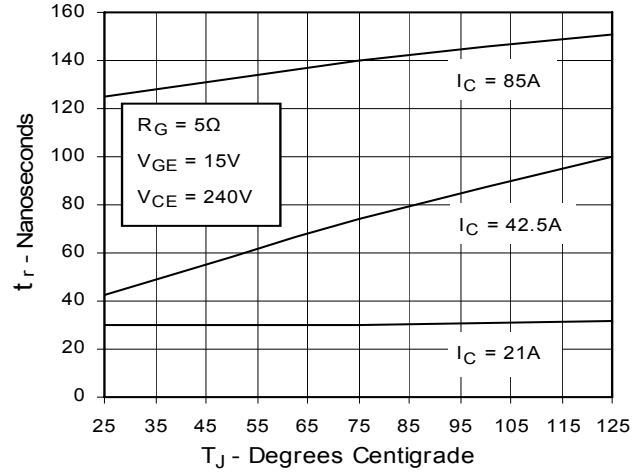

Fig. 9. Resistive Turn-On Rise Time vs. Collector Current

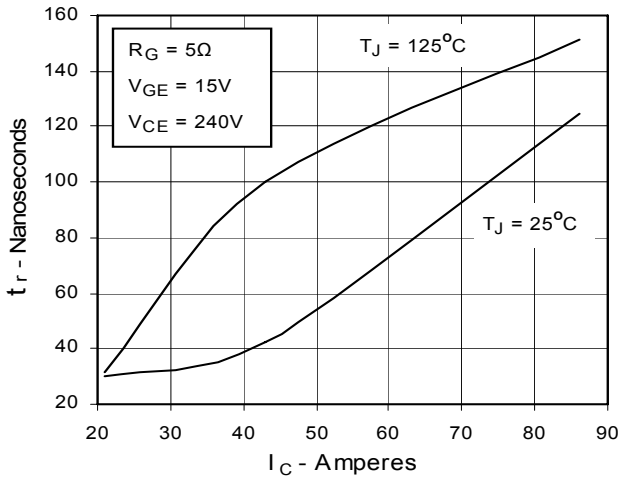

Fig. 10. Resistive Turn-On Rise Time vs. Gate Resistance

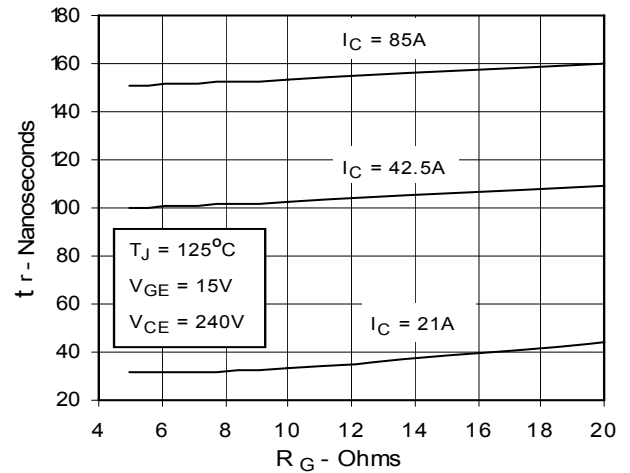

Fig. 11. Resistive Turn-On Delay Time vs. Gate Resistance

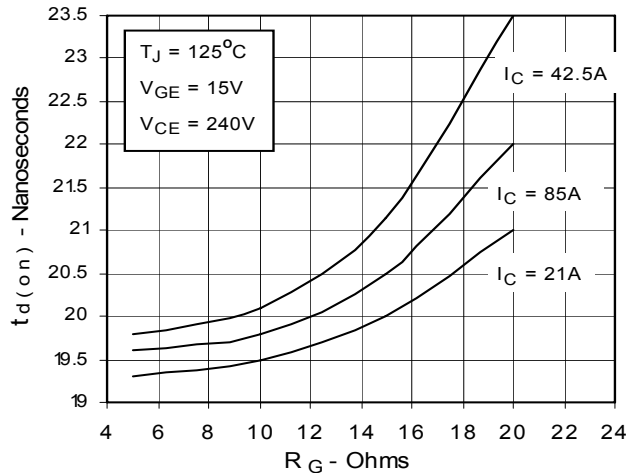

Fig. 12. Resistive Turn-Off Switching Time vs. Junction Temperature

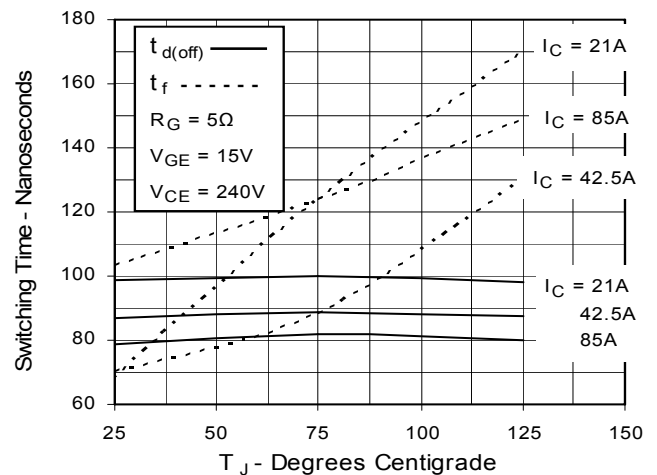

Fig. 13. Resistive Turn-Off Switching Time vs. Collector Current

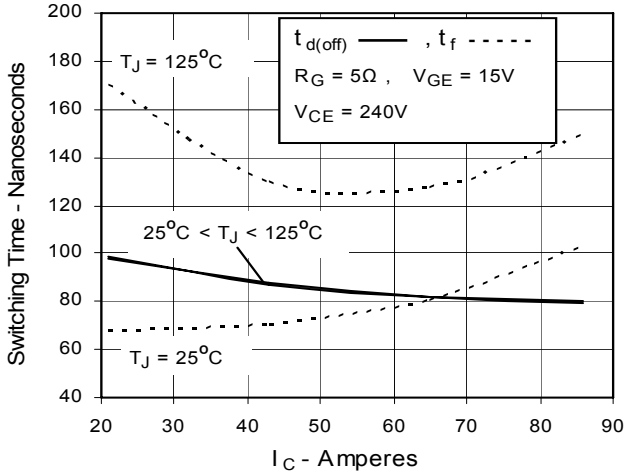

Fig. 14. Resistive Turn-off Switching Time vs. Gate Resistance

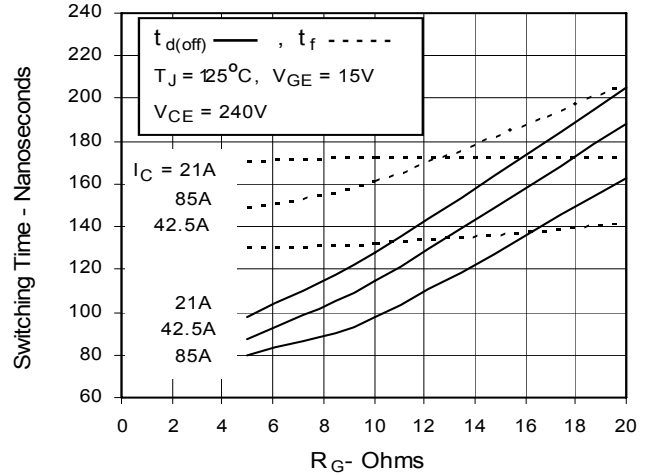

Fig. 15. Reverse-Bias Safe Operating Area

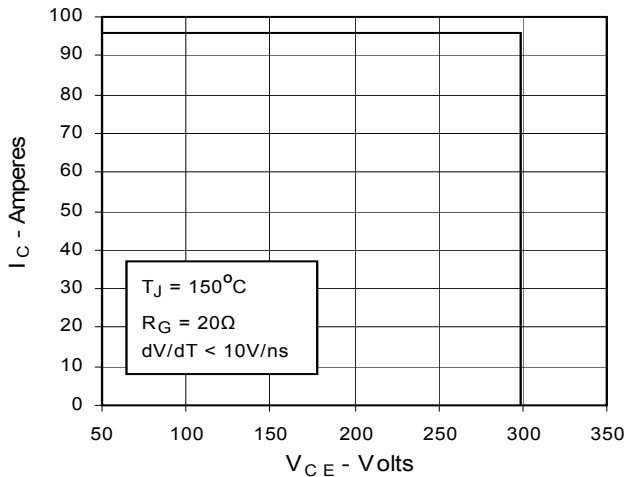

Fig. 16. Gate Charge

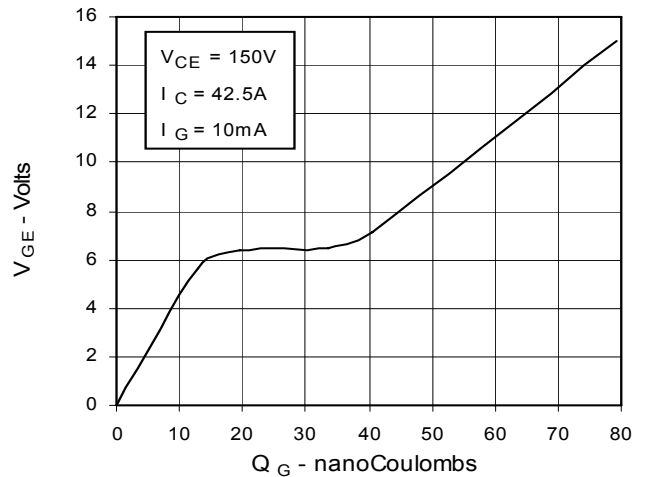

Fig. 17. Capacitance

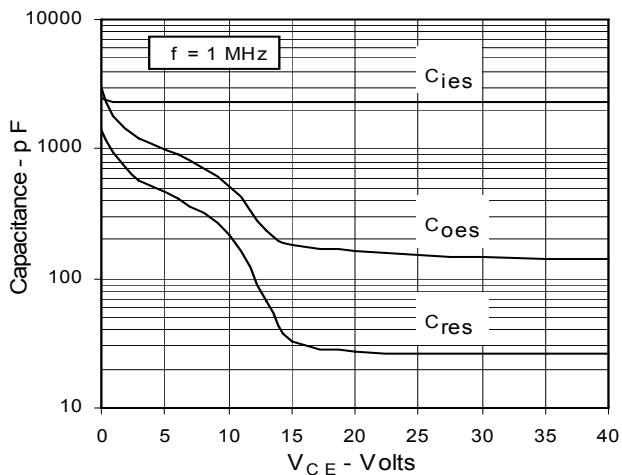

Fig. 18. Maximum Transient Thermal Resistance

