

Excellent Integrated System Limited

Stocking Distributor

Click to view price, real time Inventory, Delivery & Lifecycle Information:

[IXYS Corporation](#)

[VBO52-16NO7](#)

For any questions, you can email us directly:

sales@integrated-circuit.com

Standard Rectifier Module

1~ Rectifier	
V_{RRM}	= 1600 V
I_{DAV}	= 60 A
I_{FSM}	= 550 A

1~ Rectifier Bridge

Part number

VBO52-16NO7



 E72873

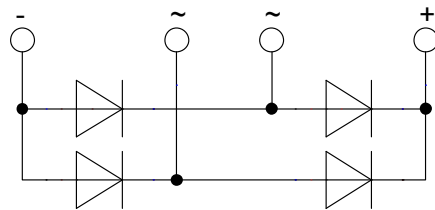

Features / Advantages:

- Package with DCB ceramic
- Improved temperature and power cycling
- Planar passivated chips
- Very low forward voltage drop
- Very low leakage current

Applications:

- Diode for main rectification
- For one phase bridge configurations
- Supplies for DC power equipment
- Input rectifiers for PWM inverter
- Battery DC power supplies
- Field supply for DC motors

Package: PWS-D

- Industry standard outline
- RoHS compliant
- Easy to mount with two screws
- Base plate: Copper internally DCB isolated
- Advanced power cycling

Rectifier				Ratings			
Symbol	Definition	Conditions	min.	typ.	max.	Unit	
V_{RSM}	max. non-repetitive reverse blocking voltage				1700	V	
V_{RRM}	max. repetitive reverse blocking voltage				1600	V	
I_R	reverse current	$V_R = 1600$ V			40	μ A	
		$V_R = 1600$ V			1.5	mA	
V_F	forward voltage drop	$I_F = 20$ A			1.07	V	
		$I_F = 40$ A			1.19	V	
		$I_F = 20$ A	$T_{VJ} = 125^\circ$ C			0.96	V
		$I_F = 40$ A				1.13	V
I_{DAV}	bridge output current	$T_C = 115^\circ$ C rectangular $d = 0.5$			60	A	
V_{F0}	threshold voltage	} for power loss calculation only			0.78	V	
r_F	slope resistance				8.1	m Ω	
R_{thJC}	thermal resistance junction to case				1.1	K/W	
R_{thCH}	thermal resistance case to heatsink			0.4		K/W	
P_{tot}	total power dissipation				110	W	
I_{FSM}	max. forward surge current	$t = 10$ ms; (50 Hz), sine	$T_{VJ} = 45^\circ$ C		550	A	
		$t = 8,3$ ms; (60 Hz), sine	$V_R = 0$ V		595	A	
		$t = 10$ ms; (50 Hz), sine	$T_{VJ} = 150^\circ$ C		470	A	
		$t = 8,3$ ms; (60 Hz), sine	$V_R = 0$ V		505	A	
I^2t	value for fusing	$t = 10$ ms; (50 Hz), sine	$T_{VJ} = 45^\circ$ C		1.52	kA ² s	
		$t = 8,3$ ms; (60 Hz), sine	$V_R = 0$ V		1.48	kA ² s	
		$t = 10$ ms; (50 Hz), sine	$T_{VJ} = 150^\circ$ C		1.11	kA ² s	
		$t = 8,3$ ms; (60 Hz), sine	$V_R = 0$ V		1.06	kA ² s	
C_J	junction capacitance	$V_R = 400$ V; $f = 1$ MHz			19	pF	



VBO52-16NO7

Package PWS-D		Ratings				
Symbol	Definition	Conditions	min.	typ.	max.	Unit
I_{RMS}	RMS current	per terminal			150	A
T_{stg}	storage temperature		-40		125	°C
T_{vj}	virtual junction temperature		-40		150	°C
Weight				153		g
M_D	mounting torque		4.25		5.75	Nm
M_T	terminal torque		4.25		5.75	Nm
$d_{Spp/App}$	creepage distance on surface striking distance through air	terminal to terminal	9.5			mm
$d_{Spb/Apb}$		terminal to backside	26.0			mm
V_{ISOL}	isolation voltage	t = 1 second	3000			V
		t = 1 minute	2500			V

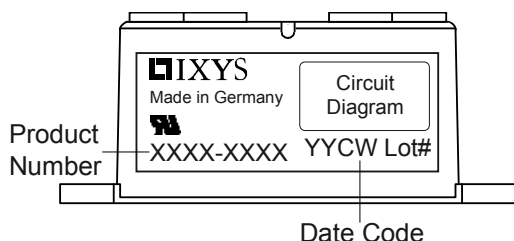

Ordering	Part Number	Marking on Product	Delivery Mode	Quantity	Code No.
Standard	VBO52-16NO7	VBO52-16NO7	Box	10	472352

Equivalent Circuits for Simulation

* on die level

$T_{vj} = 150\text{ °C}$

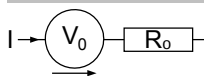

Rectifier

$V_{0\ max}$	threshold voltage	0.78	V
$R_{0\ max}$	slope resistance *	6.9	mΩ

Outlines PWS-D

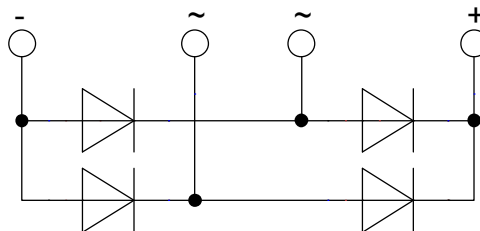
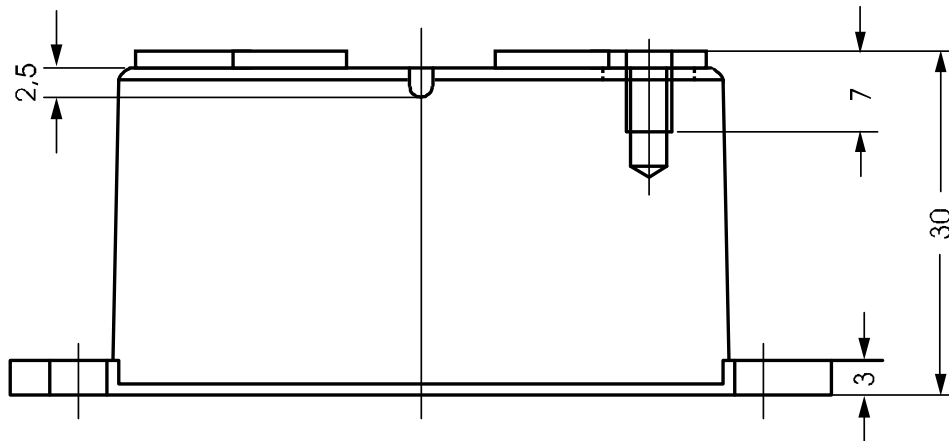
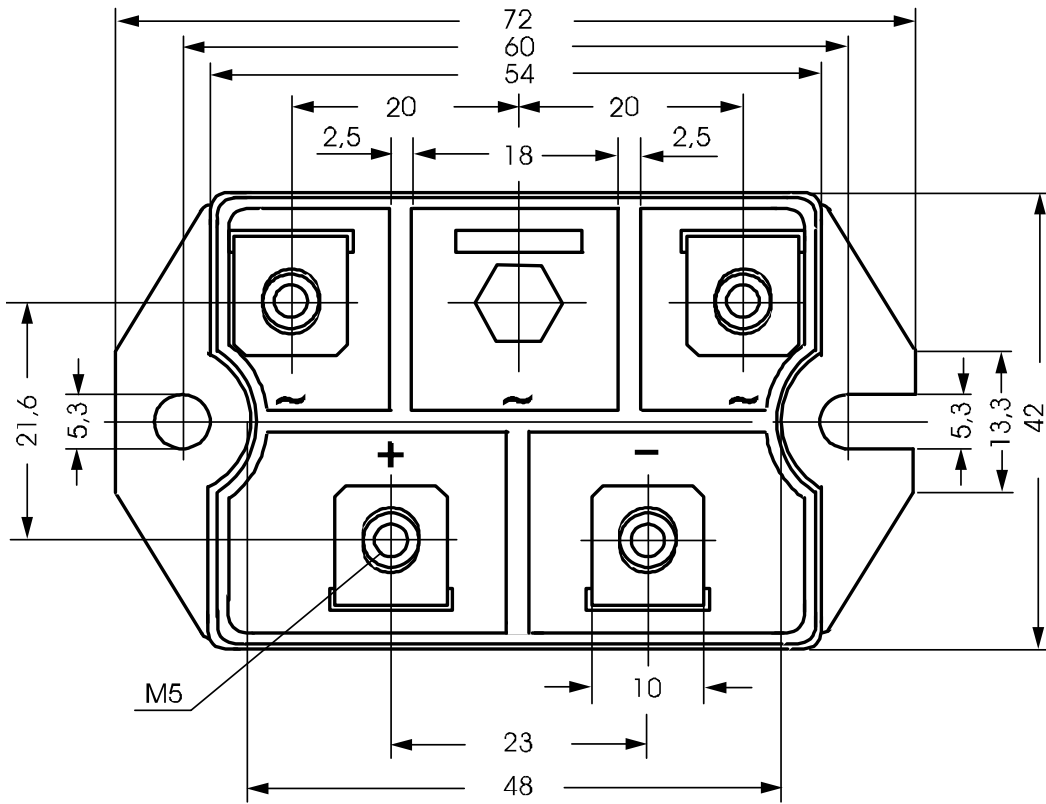

Rectifier

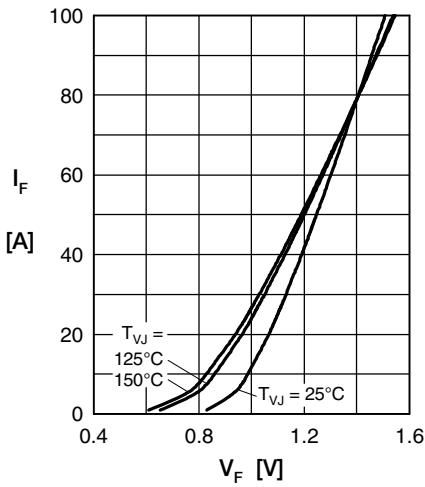

Fig. 1 Forward current vs. voltage drop per diode

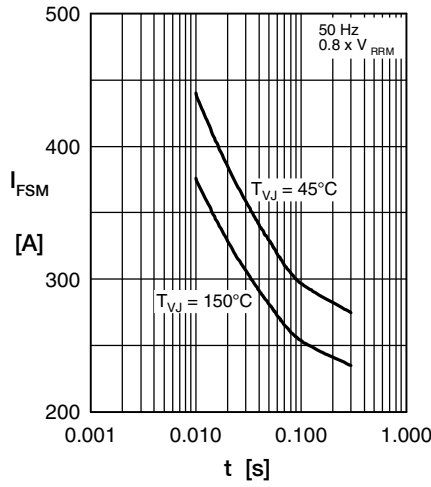

Fig. 2 Surge overload current vs. time per diode

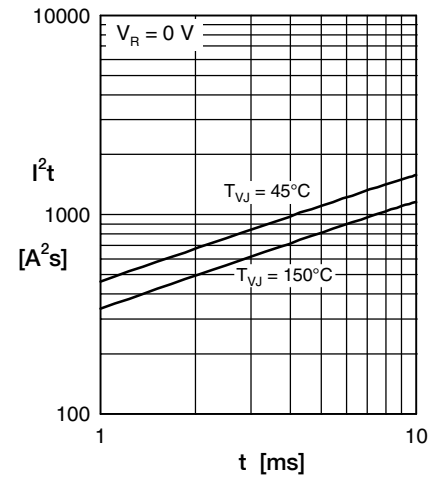

Fig. 3 I²t vs. time per diode

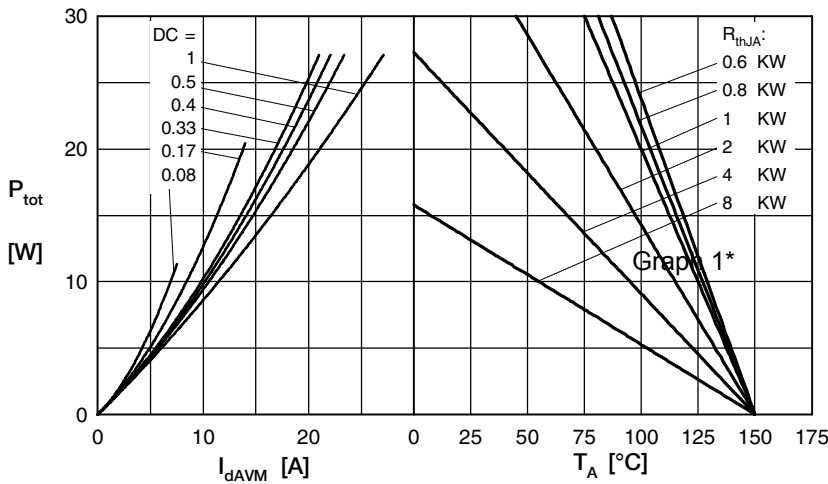

Fig. 4 Power dissipation vs. forward current and ambient temperature per diode

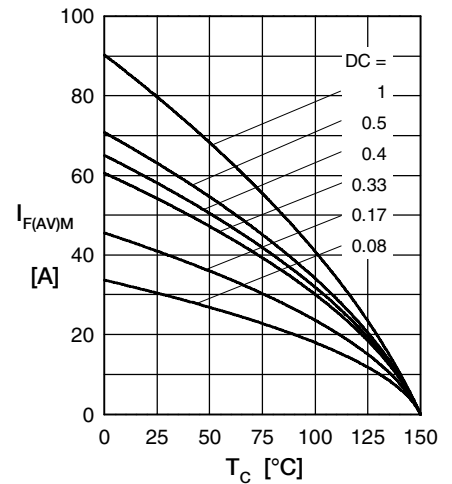

Fig. 5 Max. forward current vs. case temperature per diode

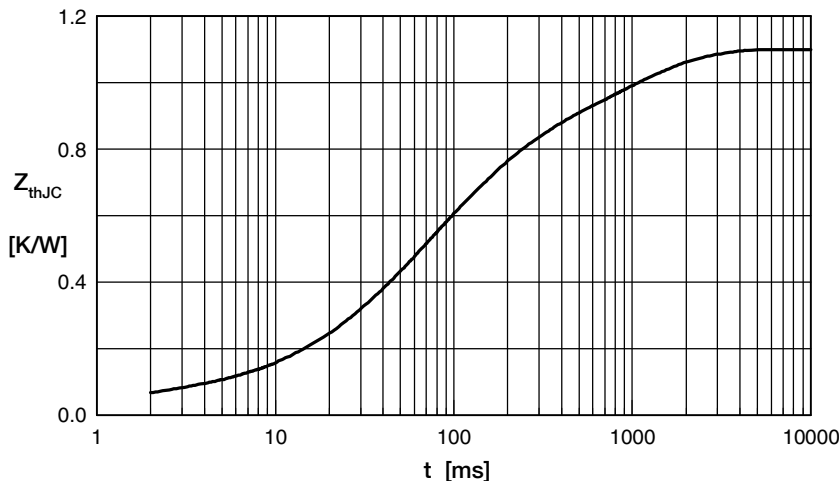

Fig. 6 Transient thermal impedance junction to case vs. time per diode

Constants for Z_{thJC} calculation:

i	R_{th} (K/W)	t_i (s)
1	0.05	0.001
2	0.14	0.030
3	0.25	0.060
4	0.35	0.130
5	0.31	0.920