

Excellent Integrated System Limited

Stocking Distributor

Click to view price, real time Inventory, Delivery & Lifecycle Information:

[IXYS Corporation](#)
[VUO110-12NO7](#)

For any questions, you can email us directly:

sales@integrated-circuit.com

Standard Rectifier Module

| | |
|-------------------------|----------|
| 3~ Rectifier | |
| V_{RRM} | = 1200 V |
| I_{DAV} | = 125 A |
| I_{FSM} | = 1200 A |

3~ Rectifier Bridge

Part number

VUO110-12N07

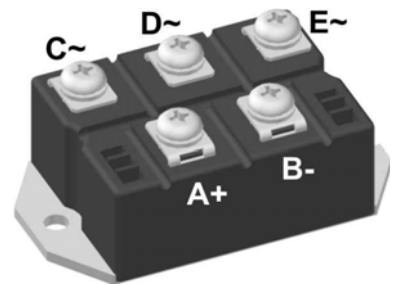

 E72873

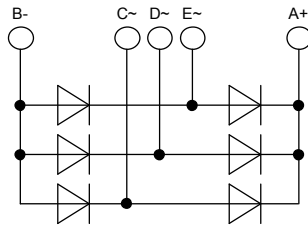

Features / Advantages:

- Package with DCB ceramic
- Improved temperature and power cycling
- Planar passivated chips
- Very low forward voltage drop
- Very low leakage current

Applications:

- Diode for main rectification
- For three phase bridge configurations
- Supplies for DC power equipment
- Input rectifiers for PWM inverter
- Battery DC power supplies
- Field supply for DC motors

Package: PWS-E

- Industry standard outline
- RoHS compliant
- Easy to mount with two screws
- Base plate: Copper internally DCB isolated
- Advanced power cycling

| Rectifier | | | | Ratings | | | |
|------------|--|--|------------------------------|------------------------------|------|-------------------|-------------------|
| Symbol | Definition | Conditions | min. | typ. | max. | Unit | |
| V_{RSM} | max. non-repetitive reverse blocking voltage | | | | 1300 | V | |
| V_{RRM} | max. repetitive reverse blocking voltage | | | | 1200 | V | |
| I_R | reverse current | $V_R = 1200\text{ V}$ | $T_{VJ} = 25^\circ\text{C}$ | | 100 | μA | |
| | | $V_R = 1200\text{ V}$ | $T_{VJ} = 150^\circ\text{C}$ | | 2 | mA | |
| V_F | forward voltage drop | $I_F = 50\text{ A}$ | $T_{VJ} = 25^\circ\text{C}$ | | 1.13 | V | |
| | | | | | 1.46 | V | |
| | | $I_F = 150\text{ A}$ | $T_{VJ} = 125^\circ\text{C}$ | | 1.04 | V | |
| | | | | | 1.47 | V | |
| I_{DAV} | bridge output current | $T_C = 110^\circ\text{C}$ rectangular $d = \frac{1}{3}$ | $T_{VJ} = 150^\circ\text{C}$ | | 125 | A | |
| | | | | | | | |
| V_{F0} | threshold voltage | } for power loss calculation only | $T_{VJ} = 150^\circ\text{C}$ | | 0.79 | V | |
| r_F | slope resistance | | | | 4.5 | m Ω | |
| R_{thJC} | thermal resistance junction to case | | | | 0.7 | K/W | |
| R_{thCH} | thermal resistance case to heatsink | | | 0.3 | | K/W | |
| P_{tot} | total power dissipation | | $T_C = 25^\circ\text{C}$ | | 175 | W | |
| I_{FSM} | max. forward surge current | $t = 10\text{ ms}; (50\text{ Hz}), \text{ sine}$ | $T_{VJ} = 45^\circ\text{C}$ | | 1.20 | kA | |
| | | | | | 1.30 | kA | |
| | | $t = 8,3\text{ ms}; (60\text{ Hz}), \text{ sine}$ | $V_R = 0\text{ V}$ | $T_{VJ} = 150^\circ\text{C}$ | | 1.02 | kA |
| | | | | | | 1.10 | kA |
| I^2t | value for fusing | $t = 10\text{ ms}; (50\text{ Hz}), \text{ sine}$ | $T_{VJ} = 45^\circ\text{C}$ | | 7.20 | kA ² s | |
| | | | | | 6.98 | kA ² s | |
| | | $t = 8,3\text{ ms}; (60\text{ Hz}), \text{ sine}$ | $V_R = 0\text{ V}$ | $T_{VJ} = 150^\circ\text{C}$ | | 5.20 | kA ² s |
| | | | | | | 5.04 | kA ² s |
| C_J | junction capacitance | $V_R = 400\text{ V}; f = 1\text{ MHz}$ | $T_{VJ} = 25^\circ\text{C}$ | 37 | | pF | |



VUO110-12NO7

| Package PWS-E | | Ratings | | | | |
|---------------|--|----------------------|------|------|------|------|
| Symbol | Definition | Conditions | min. | typ. | max. | Unit |
| I_{RMS} | RMS current | per terminal | | | 200 | A |
| T_{stg} | storage temperature | | -40 | | 125 | °C |
| T_{VJ} | virtual junction temperature | | -40 | | 150 | °C |
| Weight | | | | 284 | | g |
| M_D | mounting torque | | 4.25 | | 5.75 | Nm |
| M_T | terminal torque | | 4.25 | | 5.75 | Nm |
| $d_{Spp/App}$ | creepage distance on surface striking distance through air | terminal to terminal | 12.0 | | | mm |
| $d_{Spb/Apb}$ | | terminal to backside | 26.0 | | | mm |
| V_{ISOL} | isolation voltage | t = 1 second | 3000 | | | V |
| | | t = 1 minute | 2500 | | | V |

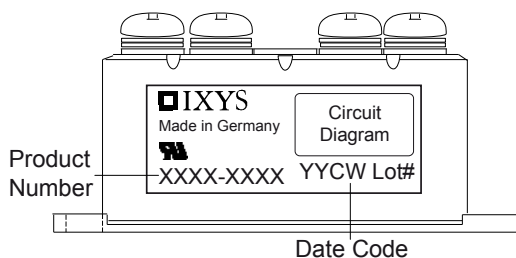

| Ordering | Part Number | Marking on Product | Delivery Mode | Quantity | Code No. |
|----------|--------------|--------------------|---------------|----------|----------|
| Standard | VUO110-12NO7 | VUO110-12NO7 | Box | 5 | 462373 |

Equivalent Circuits for Simulation

* on die level

$T_{VJ} = 150\text{ °C}$

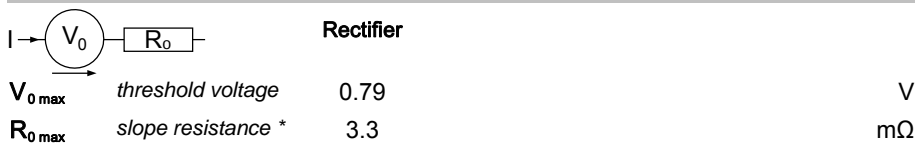

Outlines PWS-E

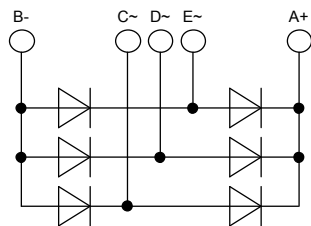
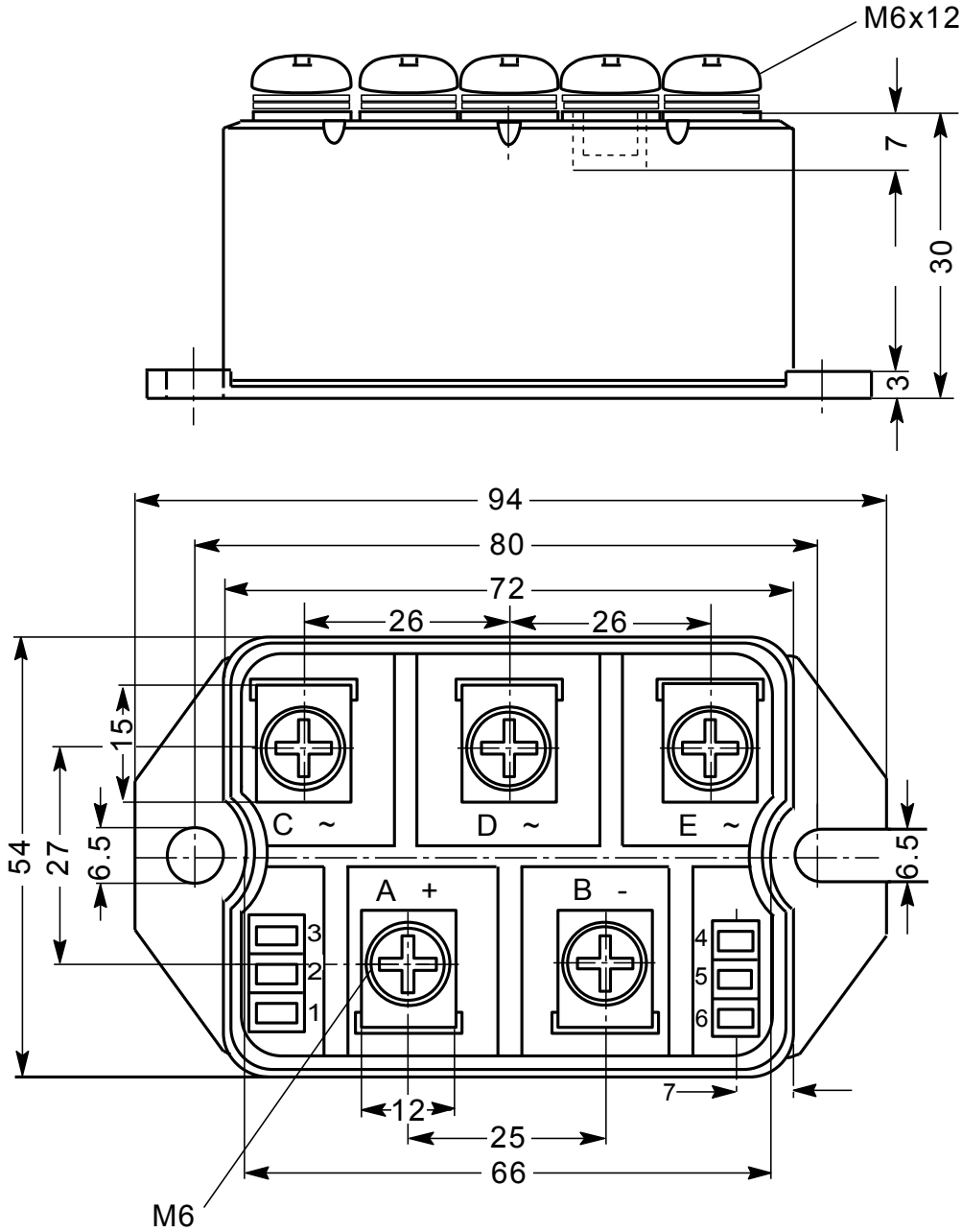

Rectifier

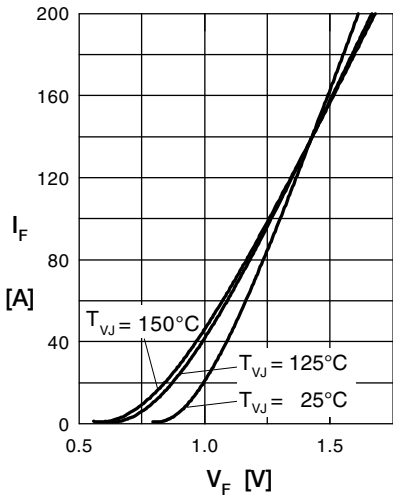

Fig. 1 Forward current vs. voltage drop per diode

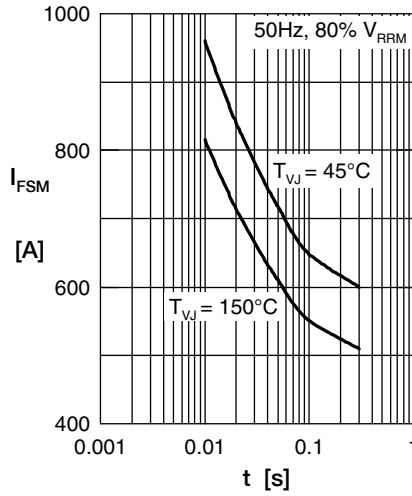

Fig. 2 Surge overload current vs. time per diode

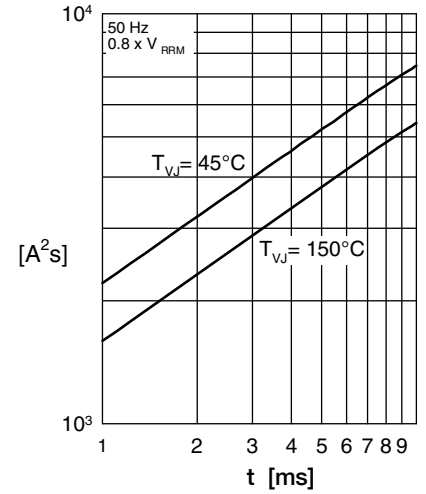

Fig. 3 I^2t vs. time per diode

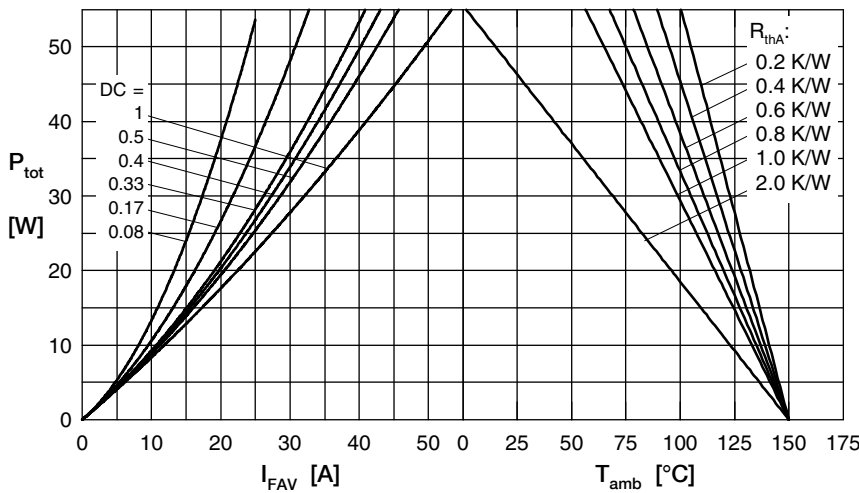

Fig. 4 Power dissipation vs. forward current and ambient temperature per diode

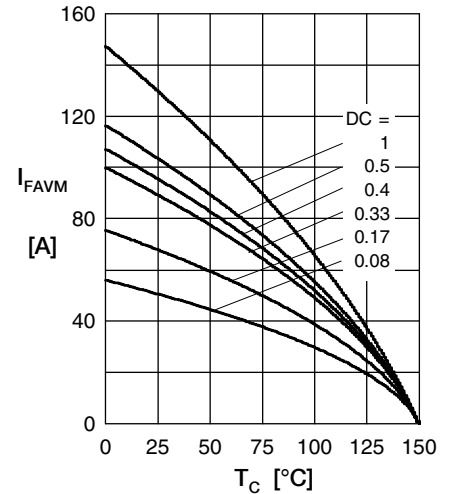

Fig. 5 Max. forward current vs. case temperature per diode

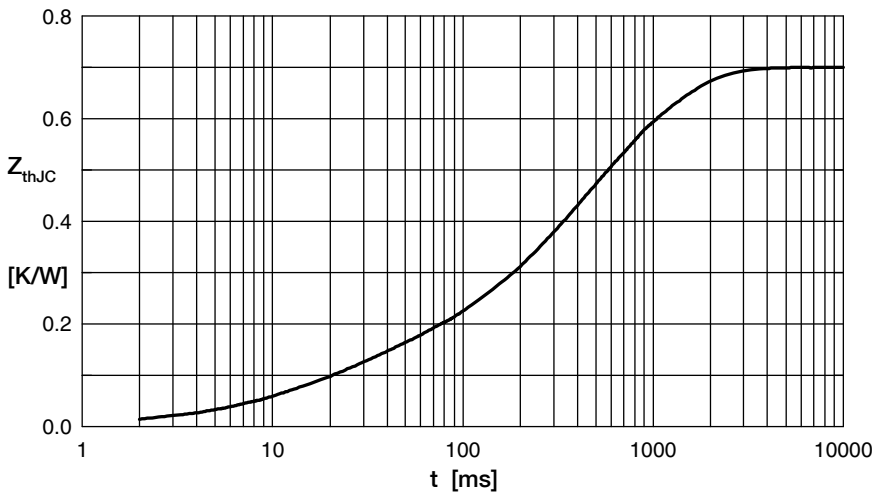

Fig. 6 Transient thermal impedance junction to case vs. time per diode