

Excellent Integrated System Limited

Stocking Distributor

Click to view price, real time Inventory, Delivery & Lifecycle Information:

[STMicroelectronics](#)

[STN690A](#)

For any questions, you can email us directly:

sales@integrated-circuit.com



STN690A

High performance low voltage NPN transistor

Features

- Very low collector to emitter saturation voltage
- DC current gain, $h_{FE} > 100$
- 3 A continuous collector current
- 40 V breakdown voltage $V_{(BR)CER}$
- SOT-223 plastic package for surface mounting circuits in tape and reel packaging

Applications

- Power management in portable equipment
- Voltage regulation in bias supply circuits
- Switching regulator in battery charger applications
- Heavy load driver

Description

The device is manufactured in low voltage NPN planar technology by using a "Base Island" layout. The resulting transistor shows exceptional high gain performance coupled with very low saturation voltage.

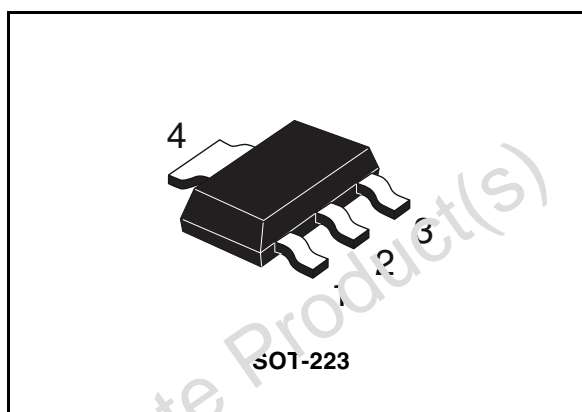

Figure 1. Internal schematic diagram

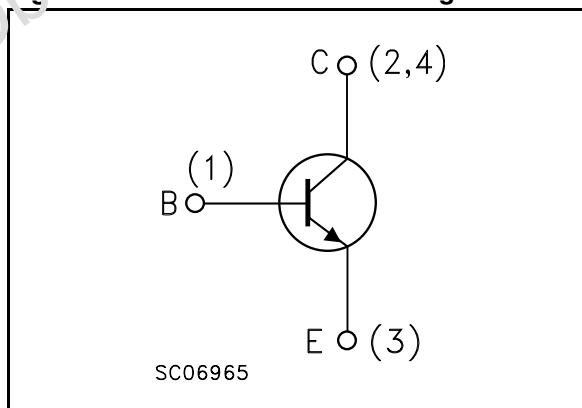

Table 1. Device summary

Order code	Marking	Package	Packaging
STN690A	N690A	SOT-223	Tape and reel

Electrical ratings

STN690A

1 Electrical ratings

Table 2. Absolute maximum ratings

Symbol	Parameter	Value	Unit
V_{CBO}	Collector-base voltage ($I_E = 0$)	40	V
V_{CER}	Collector-emitter voltage ($R_{BE} = 47 \Omega$)	40	V
V_{CEO}	Collector-emitter voltage ($I_B = 0$)	30	V
V_{EBO}	Emitter-base voltage ($I_C = 0$)	5	V
I_C	Collector current	3	A
I_{CM}	Collector peak current ($t_p < 5$ ms)	6	A
P_{tot}	Total dissipation at $T_{amb} = 25$ °C	1.6	W
T_{stg}	Storage temperature	-65 to 150	°C
T_J	Max. operating junction temperature	150	°C

Table 3. Thermal data

Symbol	Parameter	Value	Unit
$R_{thj-amb}$	Thermal resistance junction-ambient ⁽¹⁾	max 78	°C/W

1. Device mounted on PCB area of 1 cm².

STN690A
Electrical characteristics

2 Electrical characteristics

 ($T_{\text{case}} = 25\text{ }^{\circ}\text{C}$ unless otherwise specified)

Table 4. Electrical characteristics

Symbol	Parameter	Test conditions	Min.	Typ.	Max.	Unit
I_{CBO}	Collector cut-off current ($I_{\text{E}} = 0$)	$V_{\text{CB}} = 30\text{ V}$ $V_{\text{CB}} = 30\text{ V}; T_{\text{C}} = 100\text{ }^{\circ}\text{C}$			10 100	μA μA
I_{EBO}	Emitter cut-off current ($I_{\text{C}} = 0$)	$V_{\text{EB}} = 4\text{ V}$			10	μA
$V_{(\text{BR})\text{CEO}}^{(1)}$	Collector-emitter breakdown voltage ($I_{\text{B}} = 0$)	$I_{\text{C}} = 10\text{ mA}$	30			V
$V_{(\text{BR})\text{CER}}^{(1)}$	Collector-emitter breakdown voltage ($R_{\text{BE}} = 47\ \Omega$)	$I_{\text{C}} = 10\text{ mA}$	40			V
$V_{(\text{BR})\text{CBO}}$	Collector-base breakdown voltage ($I_{\text{E}} = 0$)	$I_{\text{C}} = 100\ \mu\text{A}$	40			V
$V_{(\text{BR})\text{EBO}}$	Emitter-base breakdown voltage ($I_{\text{C}} = 0$)	$I_{\text{E}} = 100\ \mu\text{A}$	5			V
$V_{\text{CE}(\text{sat})}^{(1)}$	Collector-emitter saturation voltage	$I_{\text{C}} = 0.5\text{ A}$ $I_{\text{B}} = 5\text{ mA}$ $I_{\text{C}} = 1.2\text{ A}$ $I_{\text{B}} = 20\text{ mA}$ $I_{\text{C}} = 2\text{ A}$ $I_{\text{B}} = 20\text{ mA}$ $I_{\text{C}} = 3\text{ A}$ $I_{\text{B}} = 100\text{ mA}$ $I_{\text{C}} = 3\text{ A}$ $I_{\text{B}} = 100\text{ mA}$ $T_{\text{C}} = 100\text{ }^{\circ}\text{C}$		0.08 0.1 0.175 0.2 0.3	0.15 0.22 0.35 0.4	V V V V V
$V_{\text{BE}(\text{sat})}^{(1)}$	Base-emitter saturation voltage	$I_{\text{C}} = 1\text{ A}$ $I_{\text{B}} = 10\text{ mA}$		0.8	1	V
$V_{\text{BE}(\text{on})}^{(1)}$	Base-emitter on voltage	$I_{\text{C}} = 1\text{ A}$ $V_{\text{CE}} = 2\text{ V}$		0.8	1	V
$h_{\text{FE}}^{(1)}$	DC current gain	$I_{\text{C}} = 10\text{ mA}$ $V_{\text{CE}} = 2\text{ V}$ $I_{\text{C}} = 500\text{ mA}$ $V_{\text{CE}} = 2\text{ V}$ $I_{\text{C}} = 1\text{ A}$ $V_{\text{CE}} = 2\text{ V}$ $I_{\text{C}} = 2\text{ A}$ $V_{\text{CE}} = 1\text{ V}$ $I_{\text{C}} = 3\text{ A}$ $V_{\text{CE}} = 1\text{ V}$	100 100 100 100 90	200 200 160 130	400 400	

Electrical characteristics

STN690A

Table 4. Electrical characteristics (continued)

Symbol	Parameter	Test conditions	Min.	Typ.	Max.	Unit
f_t	Transition frequency	$I_C = 50 \text{ mA}$ $V_{CE} = 5 \text{ V}$ $f = 50 \text{ MHz}$		100		MHz
t_d	Resistive load Delay time	$I_C = 3 \text{ A}$ $V_{CC} = 20 \text{ V}$		50		ns
t_r	Rise time	$I_{B1} = -I_{B2} = 60 \text{ mA}$		120		ns
t_s	Storage time	see Figure 8		465		ns
t_f	Fall time			80		ns

1. Pulse duration = 300 μs , duty cycle $\leq 1.5\%$

2.1 Electrical characteristics (curves)

Figure 2. DC current gain

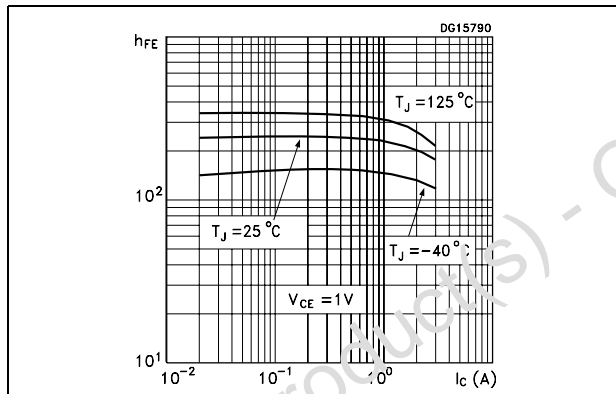

Figure 3. DC current gain

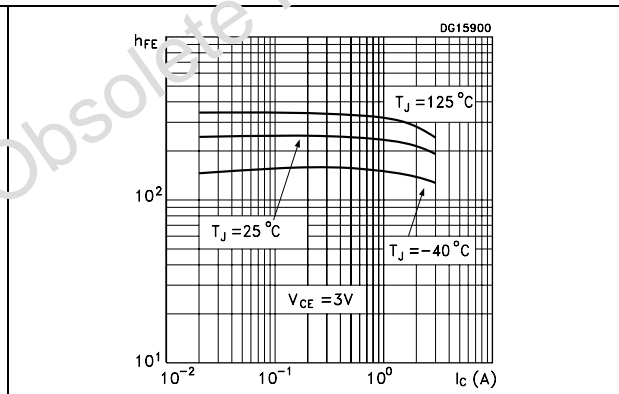

Figure 4. Collector-emitter saturation voltage

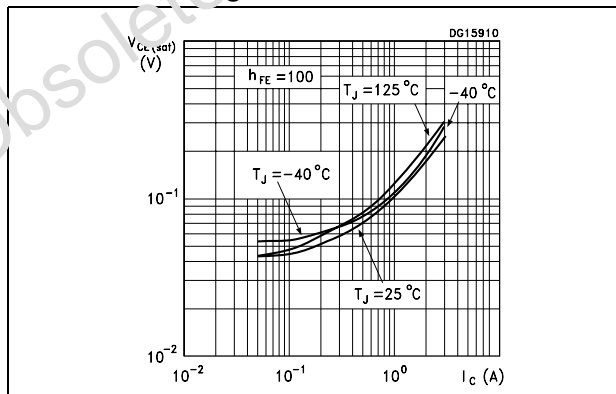
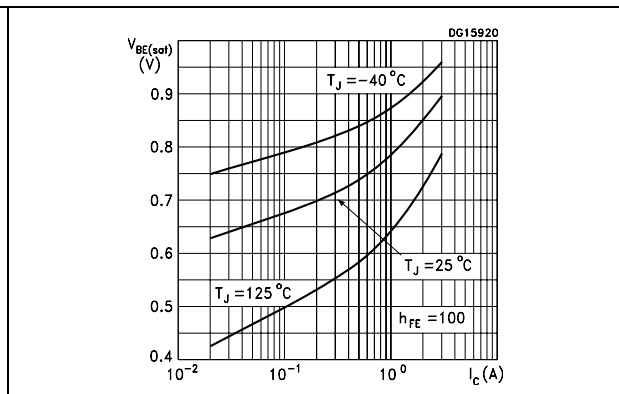

Figure 5. Base-emitter saturation voltage



STN690A

Electrical characteristics

Figure 6. Switching time resistive load

Figure 7. Switching time resistive load

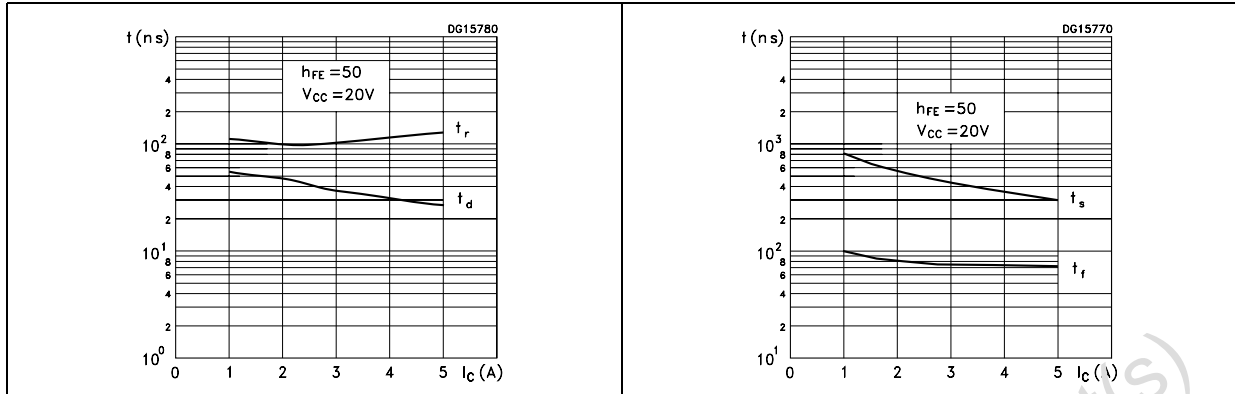

2.2 Test circuit

Figure 8. Resistive load switching test circuit

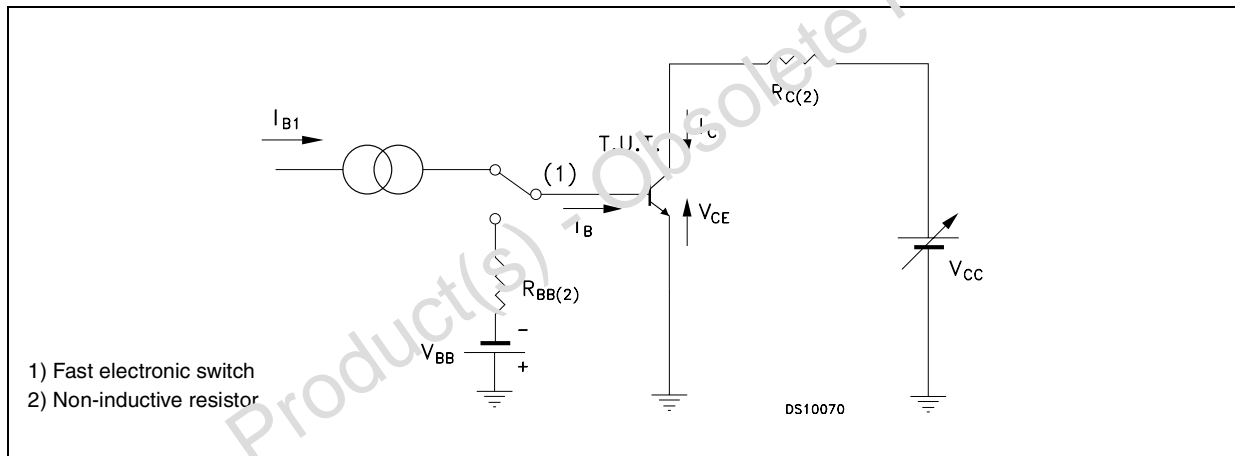

3 Package mechanical data

In order to meet environmental requirements, ST offers these devices in different grades of ECOPACK® packages, depending on their level of environmental compliance. ECOPACK® specifications, grade definitions and products status are available at: www.st.com. ECOPACK is an ST trademark.

Obsolete Product(s) - Obsolete Product(s)

STN690A

Package mechanical data

SOT-223 mechanical data

DIM.	mm.		
	min.	typ	max.
A			1.80
A1	0.02		0.1
B	0.60	0.70	0.85
B1	2.90	3.00	3.15
c	0.24	0.26	0.35
D	6.30	6.50	6.70
e		2.30	
e1		4.60	
E	3.30	3.50	3.70
H	6.70	7.00	7.30
V			10°

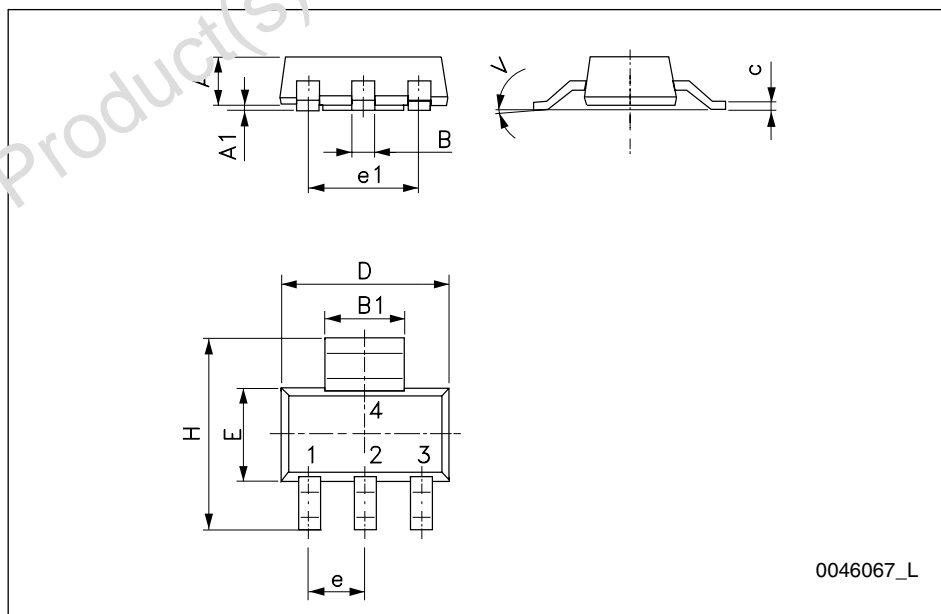

0046067_L

4 Revision history

Table 5. Document revision history

Date	Revision	Changes
20-Oct-2006	1	Initial release.
10-Feb-2009	2	Updated SOT-223 mechanical data.

Obsolete Product(s) - Obsolete Product(s)

STN690A

Please Read Carefully:

Information in this document is provided solely in connection with ST products. STMicroelectronics NV and its subsidiaries ("ST") reserve the right to make changes, corrections, modifications or improvements, to this document, and the products and services described herein at any time, without notice.

All ST products are sold pursuant to ST's terms and conditions of sale.

Purchasers are solely responsible for the choice, selection and use of the ST products and services described herein, and ST assumes no liability whatsoever relating to the choice, selection or use of the ST products and services described herein.

No license, express or implied, by estoppel or otherwise, to any intellectual property rights is granted under this document. If any part of this document refers to any third party products or services it shall not be deemed a license grant by ST for the use of such third party products or services, or any intellectual property contained therein or considered as a warranty covering the use in any manner whatsoever of such third party products or services or any intellectual property contained therein.

UNLESS OTHERWISE SET FORTH IN ST'S TERMS AND CONDITIONS OF SALE ST DISCLAIMS ANY EXPRESS OR IMPLIED WARRANTY WITH RESPECT TO THE USE AND/OR SALE OF ST PRODUCTS INCLUDING WITHOUT LIMITATION IMPLIED WARRANTIES OF MERCHANTABILITY, FITNESS FOR A PARTICULAR PURPOSE (AND THEIR EQUIVALENTS UNDER THE LAWS OF ANY JURISDICTION), OR INFRINGEMENT OF ANY PATENT, COPYRIGHT OR OTHER INTELLECTUAL PROPERTY RIGHT.

UNLESS EXPRESSLY APPROVED IN WRITING BY AN AUTHORIZED REPRESENTATIVE OF ST, ST PRODUCTS ARE NOT RECOMMENDED, AUTHORIZED OR WARRANTED FOR USE IN MILITARY, AIR CRAFT, SPACE, LIFE SAVING, OR LIFE SUSTAINING APPLICATIONS, NOR IN PRODUCTS OR SYSTEMS, WHERE FAILURE OR MALFUNCTION MAY RESULT IN PERSONAL INJURY, DEATH, OR SEVERE PROPERTY OR ENVIRONMENTAL DAMAGE. ST PRODUCTS WHICH ARE NOT SPECIFIED AS "AUTOMOTIVE GRADE" MAY ONLY BE USED IN AUTOMOTIVE APPLICATIONS AT USER'S OWN RISK.

Resale of ST products with provisions different from the statements and/or technical features set forth in this document shall immediately void any warranty granted by ST for the ST product or service described herein and shall not create or extend in any manner whatsoever, any liability of ST.

ST and the ST logo are trademarks or registered trademarks of ST in various countries.

Information in this document supersedes and replaces all information previously supplied.

The ST logo is a registered trademark of STMicroelectronics. All other names are the property of their respective owners.

© 2009 STMicroelectronics - All rights reserved

STMicroelectronics group of companies

Australia - Belgium - Brazil - Canada - China - Czech Republic - Finland - France - Germany - Hong Kong - India - Israel - Italy - Japan - Malaysia - Malta - Morocco - Singapore - Spain - Sweden - Switzerland - United Kingdom - United States of America

www.st.com