

## Excellent Integrated System Limited

Stocking Distributor

Click to view price, real time Inventory, Delivery & Lifecycle Information:

[STMicroelectronics](#)  
[VND10B](#)

For any questions, you can email us directly:

[sales@integrated-circuit.com](mailto:sales@integrated-circuit.com)



# VND10B

## DOUBLE CHANNEL HIGH SIDE SMART POWER SOLID STATE RELAY

**Table 1. General Features**

Type	V <sub>DSS</sub>	R <sub>DS(on)</sub>	I <sub>n</sub> <sup>(1)</sup>	V <sub>CC</sub>
VND10B	40 V	0.1 Ω	3.4 A	26 V

Note: 1. I<sub>n</sub>= Nominal current according to ISO definition for high side automotive switch. The Nominal Current is the current at T<sub>c</sub> = 85 °C for battery voltage of 13V which produces a voltage drop of 0.5 V.

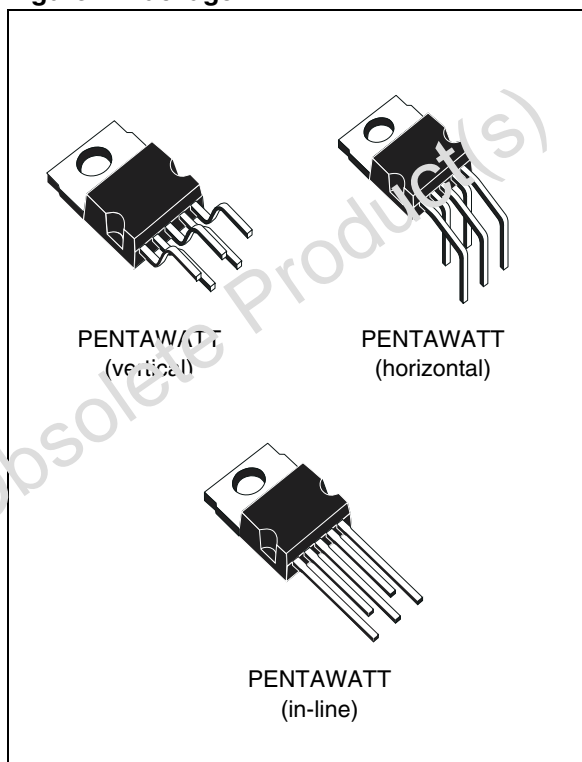
- OUTPUT CURRENT (CONTINUOUS):  
14 A @ T<sub>c</sub>=85°C PER CHANNEL
- 5V LOGIC LEVEL COMPATIBLE INPUT
- THERMAL SHUT-DOWN
- UNDER VOLTAGE PROTECTION
- OPEN DRAIN DIAGNOSTIC OUTPUT
- INDUCTIVE LOAD FAST DEMAGNETIZATION
- VERY LOW STAND-BY POWER DISSIPATION

**DESCRIPTION**

The VND10B is a monolithic device made using STMicroelectronics VPower Technology, intended for driving resistive or inductive loads with one side grounded. This device has two channels, and a common diagnostic. Built-in thermal shut down protects the chip from over temperature and short circuit.

The status output provides an indication of open load in on state, open load in off state, overtemperature conditions and stuck-on to V<sub>CC</sub>.

**Figure 1. Package**

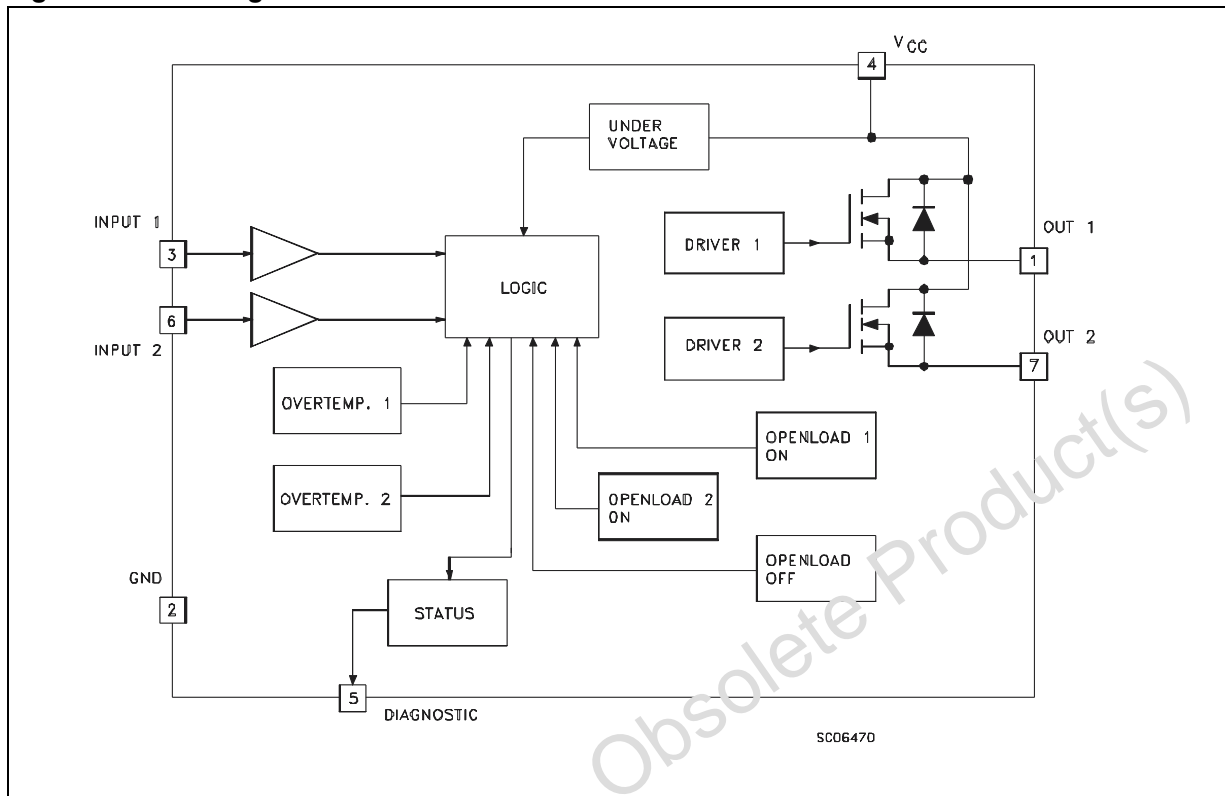


**Table 2. Order Codes**

Package	Tube	Tape and Reel
PENTAWATT Vert.	VND10B	-
PENTAWATT Hor.	VND10B(011Y)	-
PENTAWATT In line	VND10B(012Y)	-

**VND10B**

**Figure 2. Block Diagram**

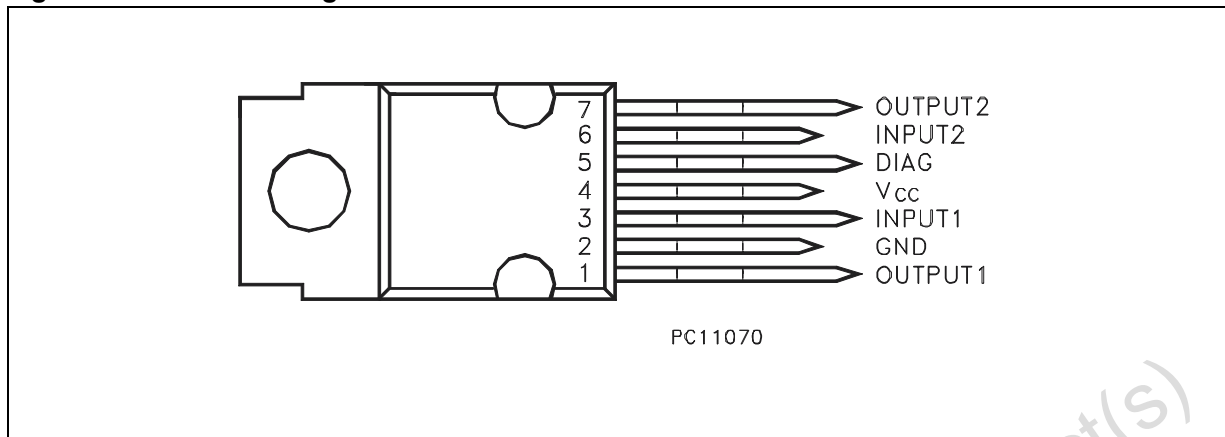


**Table 3. Absolute Maximum Ratings**

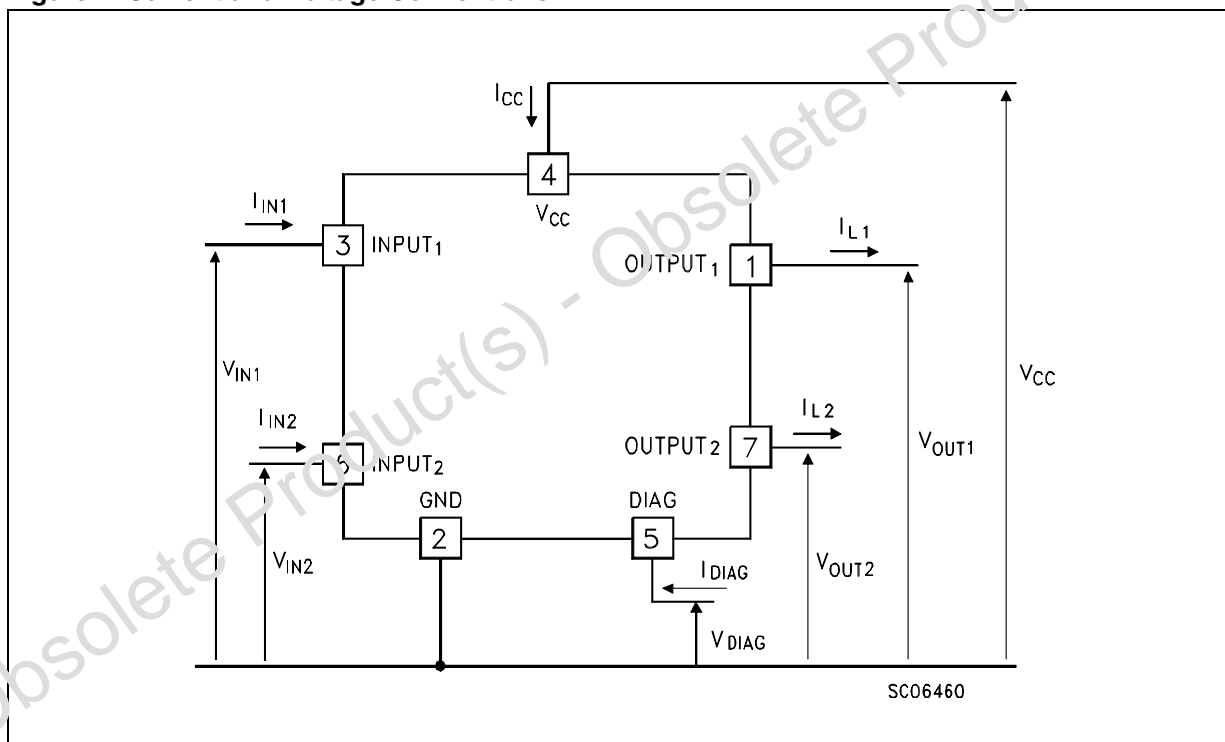
Symbol	Parameter	Value	Unit
$V_{(BR)DSS}$	Drain-Source Breakdown Voltage	40	V
$I_{OUT}$	Output Current (cont.) at $T_c = 85\text{ }^\circ\text{C}$	14	A
$I_{OUT(RMS)}$	RMS Output Current at $T_c = 85\text{ }^\circ\text{C}$	14	A
$I_R$	Reverse Output Current at $T_c = 85\text{ }^\circ\text{C}$	-14	A
$I_{IN}$	Input Current	$\pm 10$	mA
$-V_{CC}$	Reverse Supply Voltage	-4	V
$I_{STAT}$	Status Current	$\pm 10$	mA
$V_{ESD}$	Electrostatic Discharge (1.5 k $\Omega$ ; 100 pF)	2000	V
$P_{tot}$	Power Dissipation at $T_c = 25\text{ }^\circ\text{C}$	75	W
$T_j$	Junction Operating Temperature	-40 to 150	$^\circ\text{C}$
$T_{stg}$	Storage Temperature	-55 to 150	$^\circ\text{C}$

**VND10B**

**Figure 3. Connection Diagram**



**Figure 4. Current and Voltage Conventions**



**Table 4. Thermal Data**

Symbol	Parameter	Value	Unit
R <sub>thj-case</sub>	Thermal Resistance Junction-case Max	1.65	°C/W
R <sub>thj-amb</sub>	Thermal Resistance Junction-ambient Max	60	°C/W

## VND10B

### ELECTRICAL CHARACTERISTICS

( $8 < V_{CC} < 16 \text{ V}$ ;  $-40 \leq T_j \leq 125 \text{ }^\circ\text{C}$  unless otherwise specified)

**Table 5. Power**

Symbol	Parameter	Test Conditions	Min.	Typ.	Max.	Unit
$V_{CC}$	Supply Voltage		6	13	26	V
$I_n^{(2)}$	Nominal Current	$T_c = 85 \text{ }^\circ\text{C}$ ; $V_{DS(on)} \leq 0.5$ ; $V_{CC} = 13 \text{ V}$	3.4		5.2	A
$R_{on}$	On State Resistance	$I_{OUT} = I_n$ ; $V_{CC} = 13 \text{ V}$ ; $T_j = 25 \text{ }^\circ\text{C}$	0.065		0.1	$\Omega$
$I_S$	Supply Current	Off State; $T_j = 25 \text{ }^\circ\text{C}$ ; $V_{CC} = 13 \text{ V}$		35	100	$\mu\text{A}$
$V_{DS(MAX)}$	Maximum Voltage Drop	$I_{OUT} = 13 \text{ A}$ ; $T_j = 85 \text{ }^\circ\text{C}$ ; $V_{CC} = 13 \text{ V}$	1.2		2	V
$R_i$	Output to GND internal Impedance	$T_j = 25 \text{ }^\circ\text{C}$	5	10	20	$\text{k}\Omega$

Note: 2.  $I_n$  = Nominal current according to ISO definition for high side automotive switch. The Nominal Current is the current at  $T_c = 85 \text{ }^\circ\text{C}$  for battery voltage of 13V which produces a voltage drop of 0.5 V.

**Table 6. Switching**

Symbol	Parameter	Test Conditions	Min.	Typ.	Max.	Unit
$t_{d(on)}^{(3)}$	Turn-on Delay Time Of Output Current	$R_{OUT} = 2.7 \Omega$	5	35	200	$\mu\text{s}$
$t_r^{(3)}$	Rise Time Of Output Current	$R_{OUT} = 2.7 \Omega$	28	110	360	$\mu\text{s}$
$t_{d(off)}^{(3)}$	Turn-off Delay Time Of Output Current	$R_{OUT} = 2.7 \Omega$	10	140	500	$\mu\text{s}$
$t_f^{(3)}$	Fall Time Of Output Current	$R_{OUT} = 2.7 \Omega$	28	75	360	$\mu\text{s}$
$(di/dt)_{on}$	Turn-on Current Slope	$R_{OUT} = 2.7 \Omega$	0.003		0.1	$\text{A}/\mu\text{s}$
$(di/dt)_{off}$	Turn-off Current Slope	$R_{OUT} = 2.7 \Omega$	0.005		0.1	$\text{A}/\mu\text{s}$

Note: 3. See Switching Time Waveforms.

**Table 7. Logic Input**

Symbol	Parameter	Test Conditions	Min.	Typ.	Max.	Unit
$V_{IL}$	Input Low Level Voltage				1.5	V
$V_{IH}$	Input High Level Voltage		3.5		Note 4	V
$V_{I(hyst)}$	Input Hysteresis Voltage		0.2	0.9	1.5	V
$I_{IN}$	Input Current	$V_{IN} = 5 \text{ V}$ ; $T_j = 25 \text{ }^\circ\text{C}$		30	100	$\mu\text{A}$
$V_{ICL}$	Input Clamp Voltage	$I_{IN} = 10 \text{ mA}$ $I_{IN} = -10 \text{ mA}$	5	6 -0.7	7	V V

Note: 4. The  $V_{IH}$  is internally clamped at 6V about. It is possible to connect this pin to an higher voltage via an external resistor calculated to not exceed 10 mA at the input pin.

**ELECTRICAL CHARACTERISTICS (cont'd)**

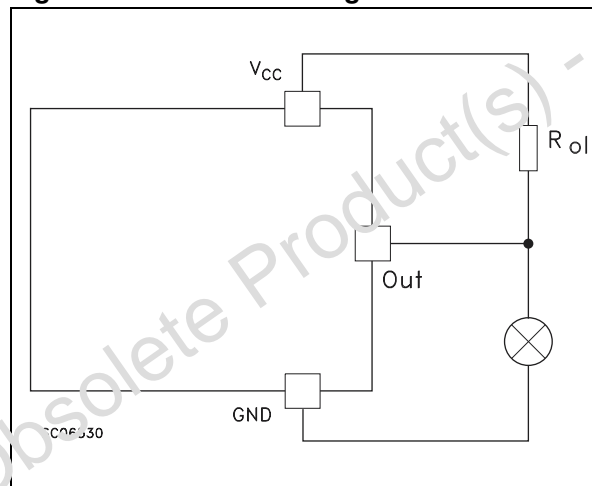
**Table 8. Protection and Diagnostics**

Symbol	Parameter	Test Conditions	Min.	Typ.	Max.	Unit
V <sub>STAT</sub>	Status Voltage Output Low	I <sub>STAT</sub> = 1.6 mA			0.4	V
V <sub>USD</sub>	Under Voltage Shut Down		3.5	4.5	6	V
V <sub>SCL</sub>	Status Clamp Voltage	I <sub>STAT</sub> = 10 mA I <sub>STAT</sub> = -10 mA	5	6 -0.7	7	V V
T <sub>TSD</sub>	Thermal Shut-down Temperature		140	160	180	°C
T <sub>SD(hyst.)</sub>	Thermal Shut-down Hysteresis				50	°C
T <sub>R</sub>	Reset Temperature		125			°C
V <sub>OL</sub> <sup>(5)</sup>	Open Voltage Level	Off-State	2.5	4	5	V
I <sub>OL</sub>	Open Load Current Level		0.6	0.9	1.4	A
t <sub>povl</sub> <sup>(6)</sup>	Status Delay			5	10	µs
t <sub>pol</sub> <sup>(6)</sup>	Status Delay		50	500	2500	µs

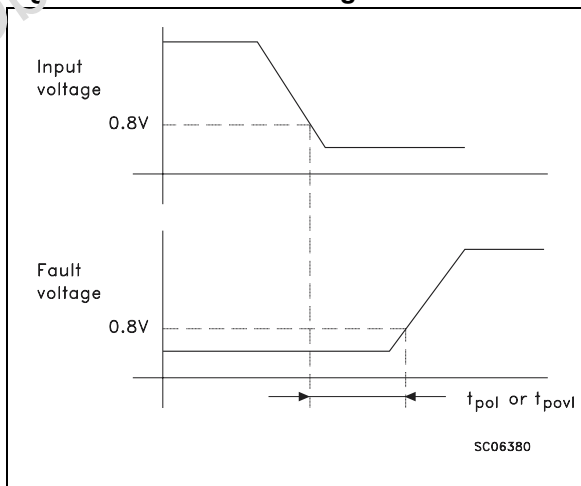
Note: 5. I<sub>OL(off)</sub> = (V<sub>CC</sub> - V<sub>OL</sub>)/R<sub>OL</sub> (see figure 5)

6. t<sub>povl</sub> t<sub>pol</sub>: ISO definition (see figure 6).

**Figure 5. Note 5 relevant figure**

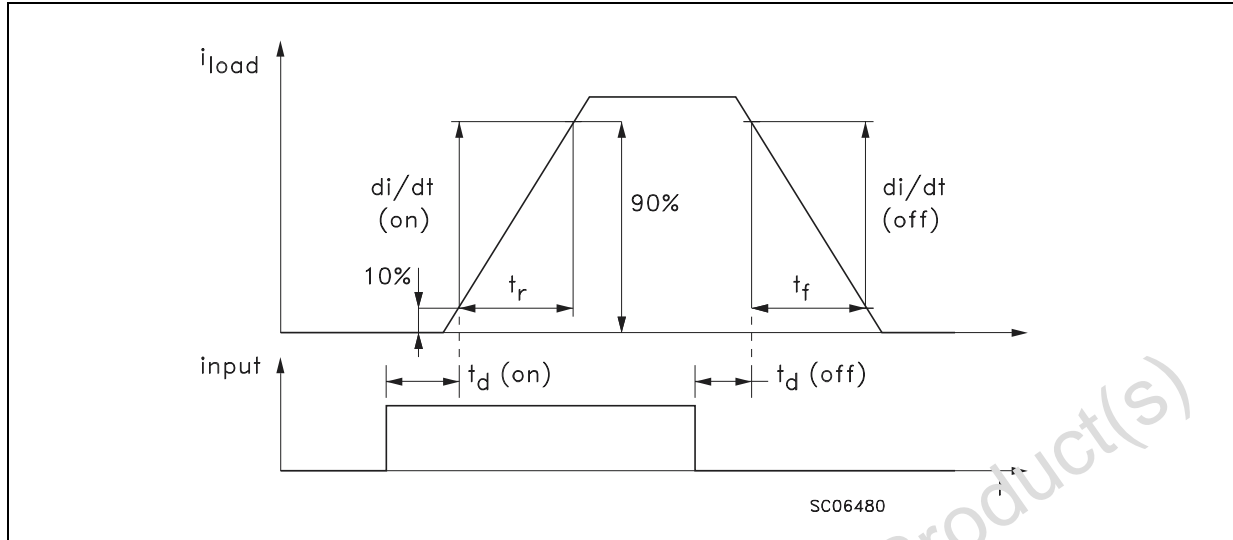


**Figure 6. Note 6 relevant figure**



**VND10B**

**Figure 7. Switching Time Waveforms**



**FUNCTIONAL DESCRIPTION**

The device has a common diagnostic output for both channels which indicates open load in on-state, open load in off-state, over temperature conditions and stuck-on to V<sub>CC</sub>.

From the falling edge of the input signal, the status output, initially low to signal a fault condition (overtemperature or open load on-state), will go back to a high state with a different delay in case of overtemperature (t<sub>poV</sub>) and in case of open load (t<sub>pol</sub>) respectively. This feature allows to discriminate the nature of the detected fault. To protect the device against short circuit and over current condition, the thermal protection turns the integrated Power MOS off at a minimum junction temperature of 140 °C. When this temperature returns to 125 °C the switch is automatically turned on again. In short circuit the protection reacts with virtually no delay, the sensor (one for each channel) being located inside each of the two Power MOS areas. This positioning allows the device to operate with one channel in automatic thermal cycling and the other one on a normal load. An internal function of the devices ensures the fast demagnetization of inductive loads with a typical voltage (V<sub>demag</sub>) of -18V. This function allows to greatly reduce the power dissipation according to the formula:

$$P_{dem} = 0.5 \cdot L_{load} \cdot (I_{load})^2 \cdot [(V_{CC} + V_{demag}) / V_{demag}] \cdot f$$

where f = switching frequency and

V<sub>demag</sub> = demagnetization voltage

The maximum inductance which causes the chip temperature to reach the shut-down temperature in a specified thermal environment is a function of the load current for a fixed V<sub>CC</sub>, V<sub>demag</sub> and f according to the above formula. In this device if the GND pin is disconnected, with V<sub>CC</sub> not exceeding 16V, both channel will switch off.

**PROTECTING THE DEVICE AGAINST REVERSE BATTERY**

The simplest way to protect the device against a continuous reverse battery voltage (-26V) is to insert a Schottky diode between pin 1(GND) and ground, as shown in the typical application circuit (Figure 9).

The consequences of the voltage drop across this diode are as follows:

- If the input is pulled to power GND, a negative voltage of -V<sub>f</sub> is seen by the device. (V<sub>IL</sub>, V<sub>IH</sub> thresholds and V<sub>STAT</sub> are increased by V<sub>f</sub> with respect to power GND).
- The undervoltage shutdown level is increased by V<sub>f</sub>.

If there is no need for the control unit to handle external analog signals referred to the power GND, the best approach is to connect the reference potential of the control unit to node [1] (see application circuit in Figure 10), which becomes the common signal GND for the whole control board avoiding shift of V<sub>IH</sub>, V<sub>IL</sub> and V<sub>STAT</sub>. This solution allows the use of a standard diode.

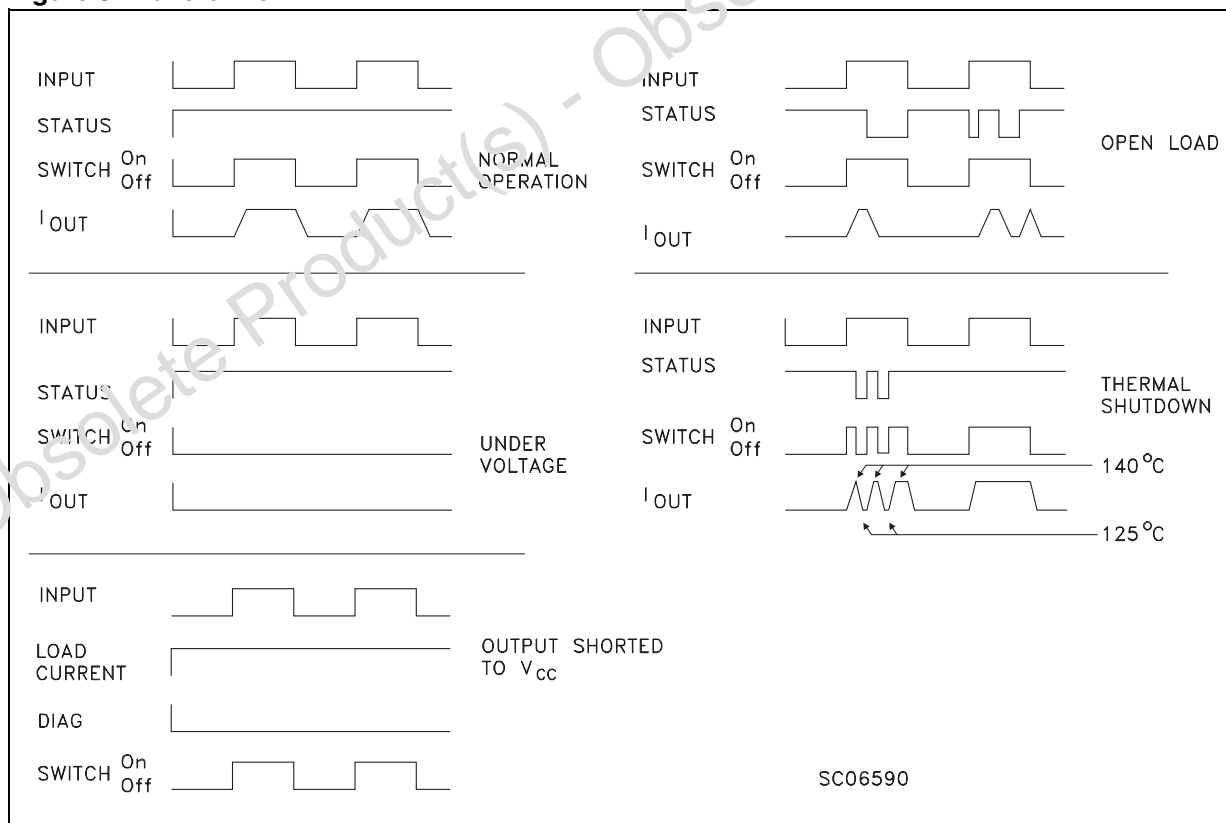
**VND10B**

**Table 9. Truth Table**

		Input 1	Input 2	Output 1	Output 2	Diagnostic
Normal Operation		L	L	L	L	H
		H	H	H	H	H
		L	H	L	H	H
		H	L	H	L	H
Under voltage		X	X	L	L	H
Thermal Shutdown	Channel 1	H	X	L	X	L
	Channel 2	X	H	X	L	L
Open Load	Channel 1	H L	X L	H L	X L	L L <sup>(7)</sup>
	Channel 2	X L	H L	X L	H L	L L <sup>(7)</sup>
Output Shorted to V <sub>CC</sub>	Channel 1	H L	X L	H H	X L	L L
	Channel 2	X L	H L	X L	H H	L L

Note: 7. With additional external resistor.

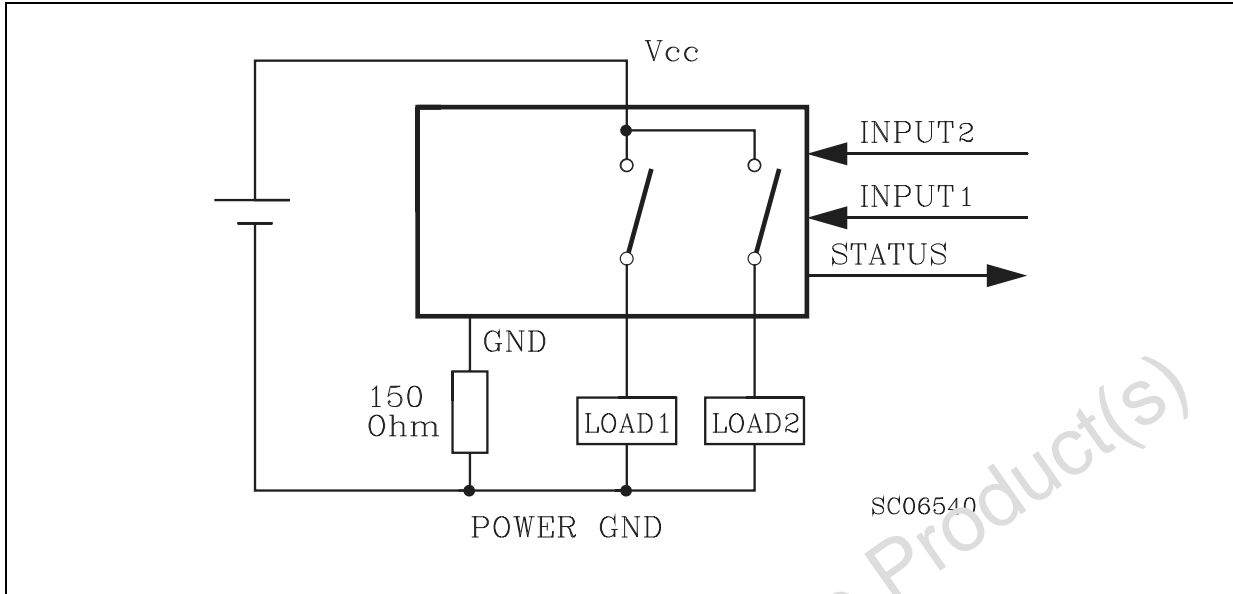
**Figure 8. Waveforms**



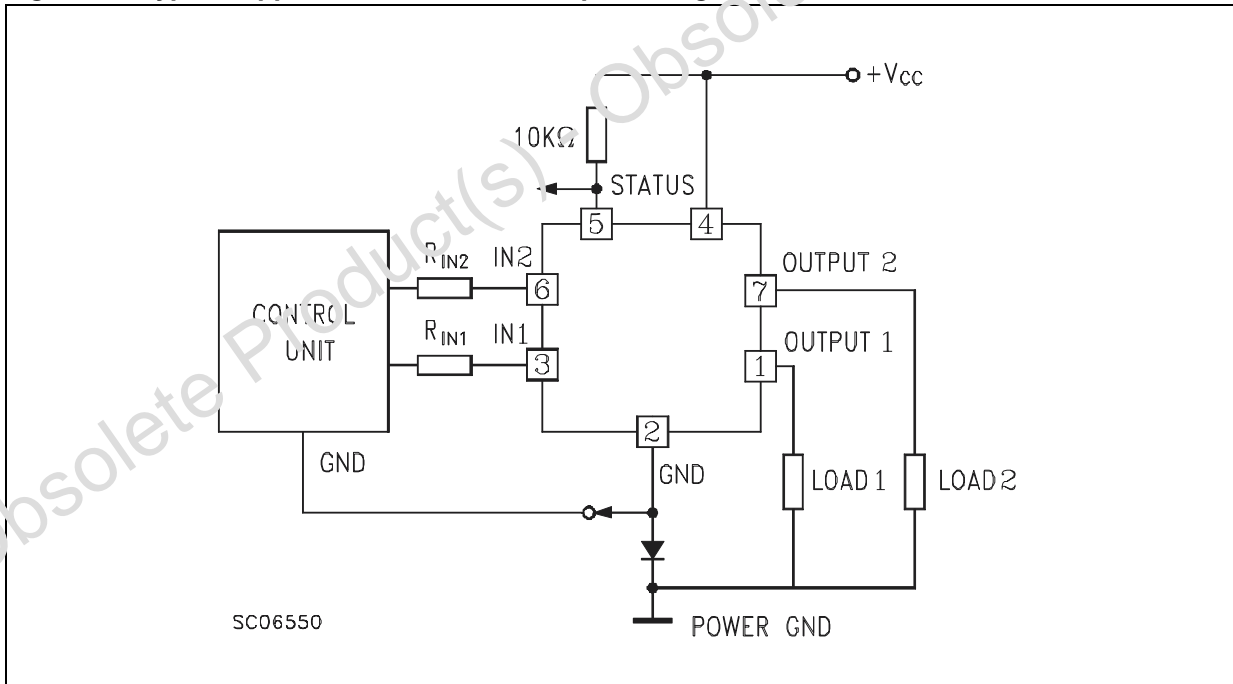


**VND10B**

**Figure 9. Typical Application Circuit With A Schottky Diode For Reverse Supply Protection**



**Figure 10. Typical Application Circuit With Separate Signal Ground**

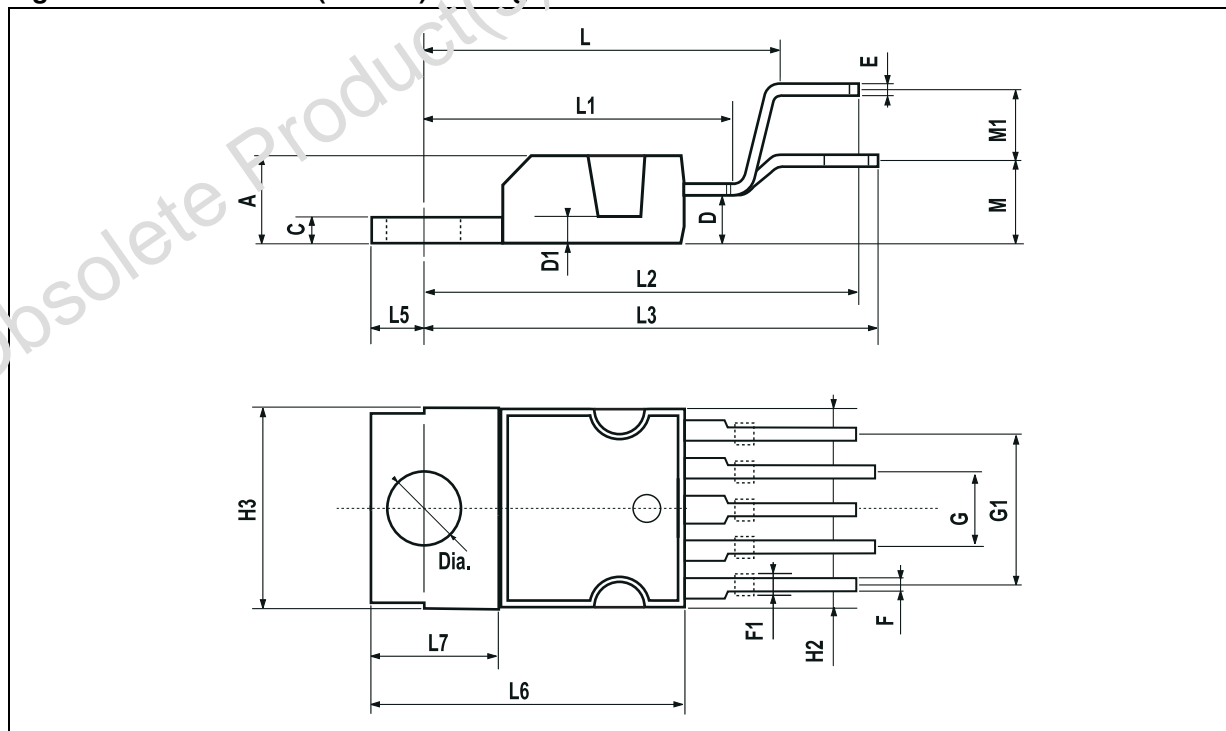


**PACKAGE MECHANICAL**

**Table 10. PENTAWATT (vertical) Mechanical Data**

Symbol	millimeters		
	Min	Typ	Max
A			4.8
C			1.37
D	2.4		2.8
D1	1.2		1.35
E	0.35		0.55
F	0.8		1.05
F1	1		1.4
G	3.2	3.4	3.6
G1	6.6	6.8	7
H2			10.4
H3	10.05		10.4
L2	23.05	23.4	23.8
L3	25.3	25.65	26.1
L5	2.6		3
L6	15.1		15.8
L7	6		6.6
Dia.	3.65		3.85

**Figure 11. PENTAWATT (vertical) Package Dimensions**



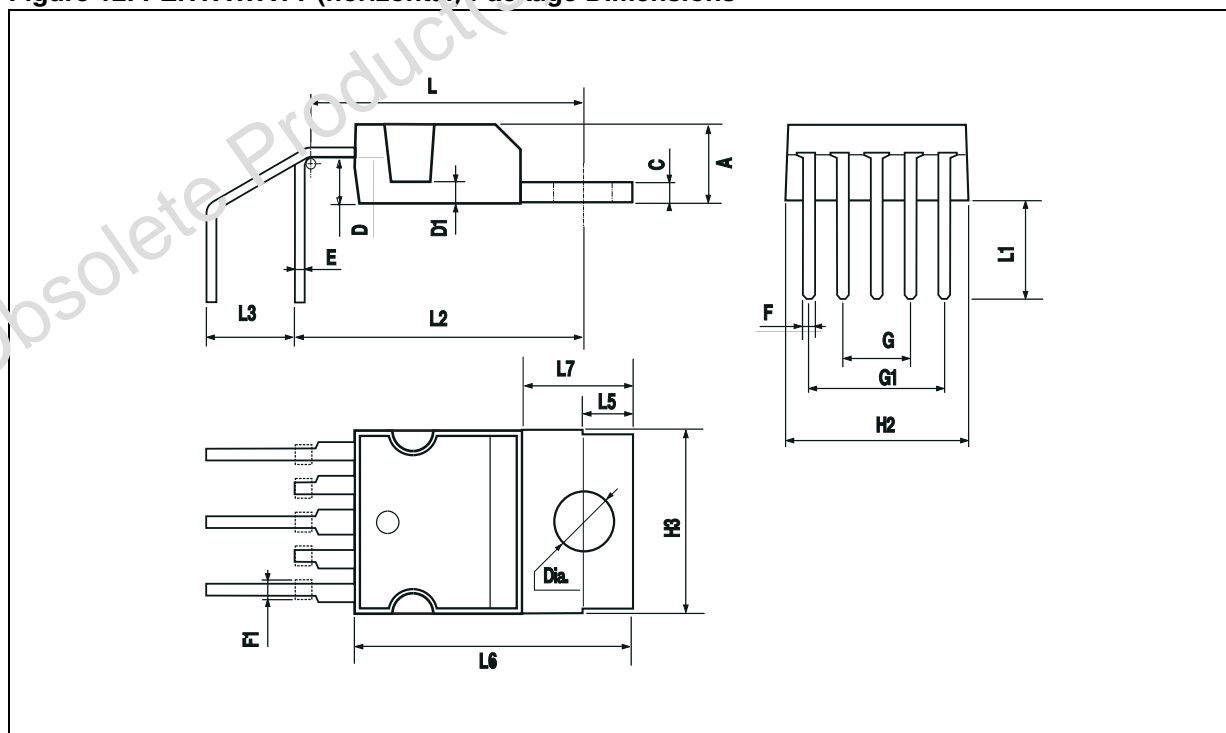
Note: Drawing is not to scale.

**VND10B**

**Table 11. PENTAWATT (horizontal) Mechanical Data**

Symbol	millimeters		
	Min	Typ	Max
A			4.8
C			1.37
D	2.4		2.8
D1	1.2		1.35
E	0.35		0.55
F	0.8		1.05
F1	1		1.4
G	3.2	3.4	3.6
G1	6.6	6.8	7
H2			10.4
H3	10.05		10.4
L	14.2		15
L1	5.7		6.2
L2	14.6		15.2
L3	3.5		4.1
L5	2.6		3
L6	15.1		15.8
L7	6		6.6
Dia.	3.65		3.85

**Figure 12. PENTAWATT (horizontal) Package Dimensions**



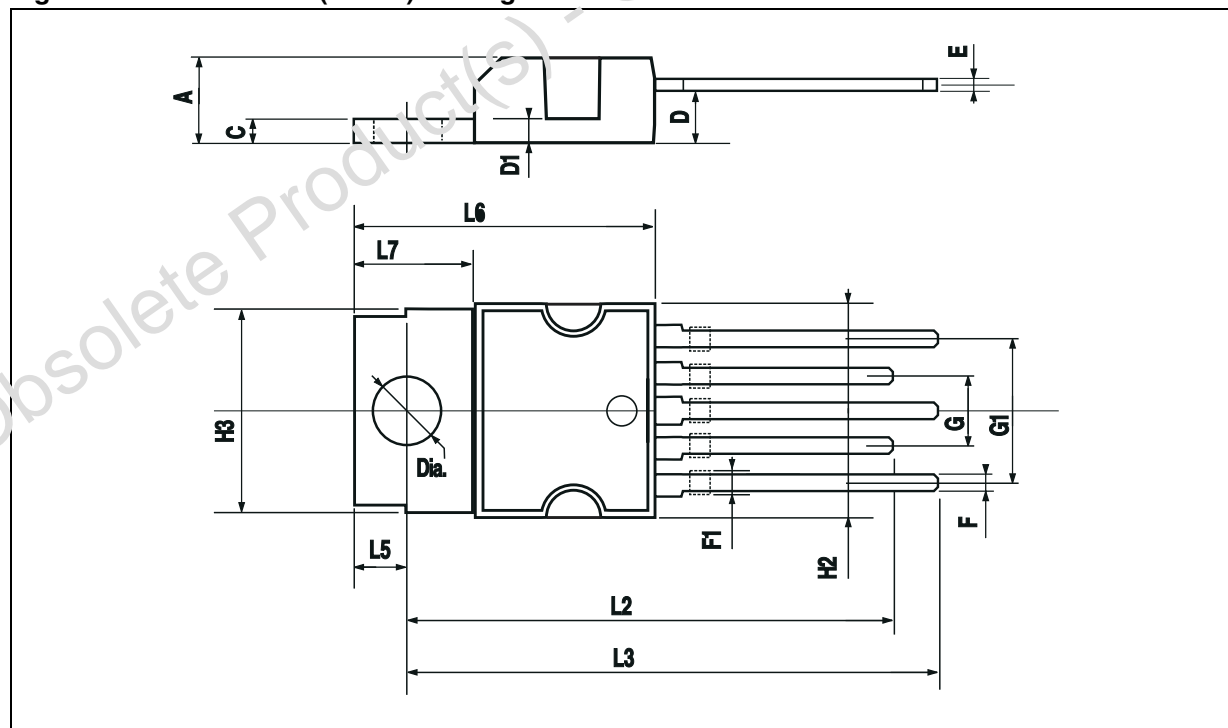
Note: Drawing is not to scale.

**VND10B**

**Table 12. PENTAWATT (in-line) Mechanical Data**

Symbol	millimeters		
	Min	Typ	Max
A			4.8
C			1.37
D	2.4		2.8
D1	1.2		1.35
E	0.35		0.55
F	0.8		1.05
F1	1		1.4
G	3.2	3.4	3.6
G1	6.6	6.8	7
H2			10.4
H3	10.05		10.4
L2	23.05	23.4	23.8
L3	25.3	25.65	26.1
L5	2.6		3
L6	15.1		15.8
L7	6		6.6
Dia.	3.65		3.85

**Figure 13. PENTAWATT (in-line) Package Dimensions**



Note: Drawing is not to scale.

**VND10B**

---

**REVISION HISTORY****Table 13. Revision History**

<b>Date</b>	<b>Revision</b>	<b>Description of Changes</b>
September-1994	1	First Issue
18-June-2004	2	Stylesheet update. No content change.

Obsolete Product(s) - Obsolete Product(s)

Obsolete Product(s) - Obsolete Product(s)

Information furnished is believed to be accurate and reliable. However, STMicroelectronics assumes no responsibility for the consequences of use of such information nor for any infringement of patents or other rights of third parties which may result from its use. No license is granted by implication or otherwise under any patent or patent rights of STMicroelectronics. Specifications mentioned in this publication are subject to change without notice. This publication supersedes and replaces all information previously supplied. STMicroelectronics products are not authorized for use as critical components in life support devices or systems without express written approval of STMicroelectronics.

The ST logo is a registered trademark of STMicroelectronics.

All other names are the property of their respective owners

© 2004 STMicroelectronics - All rights reserved

STMicroelectronics GROUP OF COMPANIES

Australia - Belgium - Brazil - Canada - China - Czech Republic - Finland - France - Germany - Hong Kong - India - Israel - Italy - Japan - Malaysia - Malta - Morocco - Singapore - Spain - Sweden - Switzerland - United Kingdom - United States

[www.st.com](http://www.st.com)