

## **Excellent Integrated System Limited**

Stocking Distributor

Click to view price, real time Inventory, Delivery & Lifecycle Information:

[Texas Instruments](#)  
[CLC730045](#)

For any questions, you can email us directly:  
[sales@integrated-circuit.com](mailto:sales@integrated-circuit.com)



# CLC109/110/111 Evaluation Boards

## Part Numbers CLC730012, CLC730045

August 1996

The CLC730012 is an evaluation board intended for the evaluation of single buffers in the DIP package. The CLC730045 is a similar board, but laid out for an SOIC package.

To obtain optimum performance from a high speed device, a good Printed Circuit Board (PCB) layout is essential. The importance of the layout becomes greater as the frequency of operation increases. Some of Comlinear's buffers have bandwidths in excess of 800 MHz, therefore it is vital that sound PCB layout techniques be used when designing with these devices. The CLC730012 and CLC730045 are examples of good PCB layouts which designers are encouraged to copy.

To minimize capacitive feedthrough and noise, the pins not connected internally, should be connected to the ground plane. Input and output traces should be laid out as transmission lines with the appropriate termination resistors very near the device. On a 0.0065" (FR4 or equivalent) a 0.1" wide trace over ground plane on the opposite side of the board will exhibit a characteristic impedance of 50 .

Figure 1 shows recommended power supply bypassing. The ferrite beads are optional and are recommended only where additional isolation is needed from high-frequency (>400MHz) resonances of the power supply.

Parasitic or load capacitance directly on the output of a buffer will introduce additional phase shift in the device. If excessive, this phase shift can lead to peaking in the frequency response or, in extreme cases, oscillation. A small series resistor in series with a capacitive load effectively decouples it from the buffer output and removes the undesirable effects of excess phase shift. Further detail on the selection of these resistors can be found in the individual buffer data sheets.

### Parts List

- $R_{IN}$  select for desired input resistance
- $R_{OUT}$  select for desired output resistance
- $C_1, C_2$  0.1 $\mu$ F capacitor
- $C_3, C_4$  6.8 $\mu$ F capacitor
- $L_1, L_2$  Optional ferrite bead inductors

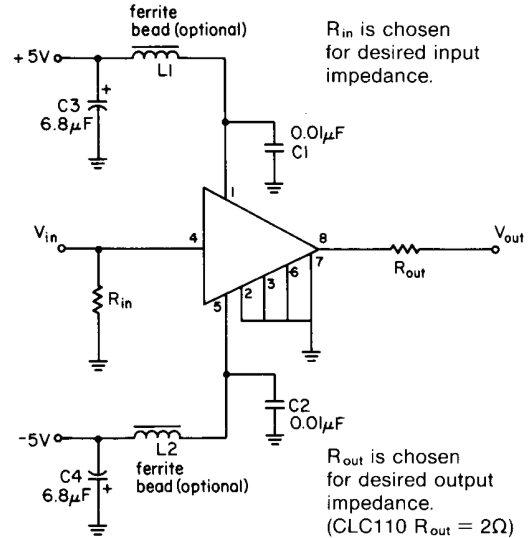

**Figure 1: Recommended Circuit and Evaluation Board Schematic**

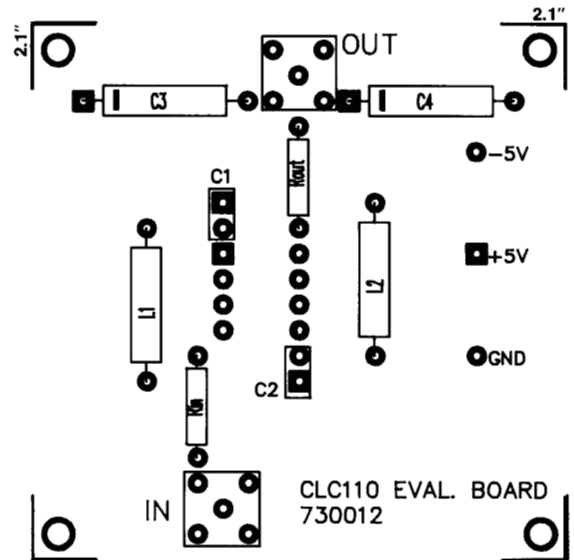

**Figure 2: Component Placement Guide**

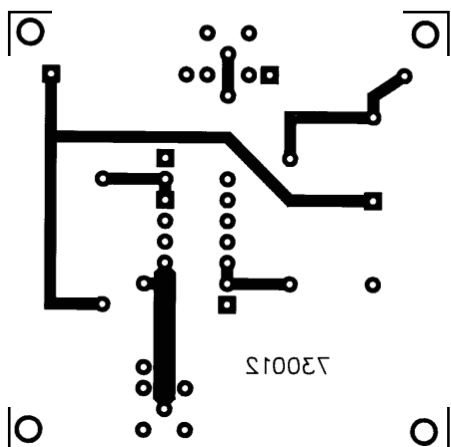

**Figure 3: 730012 Solder Side (bottom) viewed from Component Side (top)**

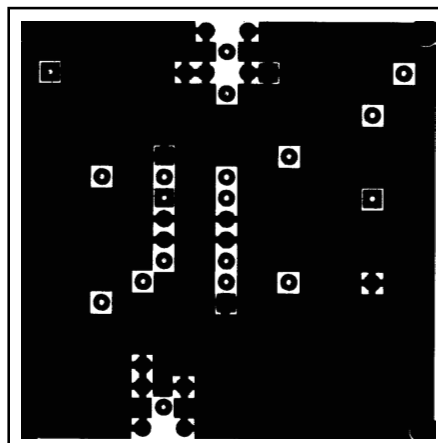

**Figure 4: 730012 Component Side (top) Showing Ground Plane**

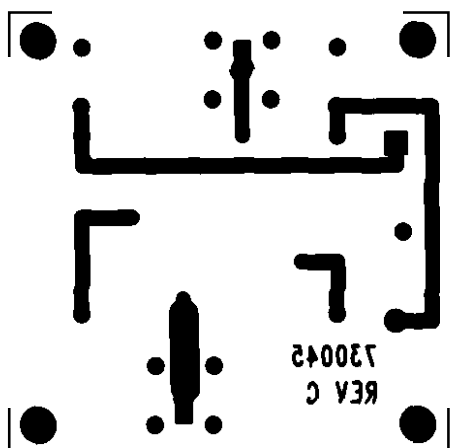

**Figure 5: 730045 Solder Side (bottom) viewed from Component Side (top)**

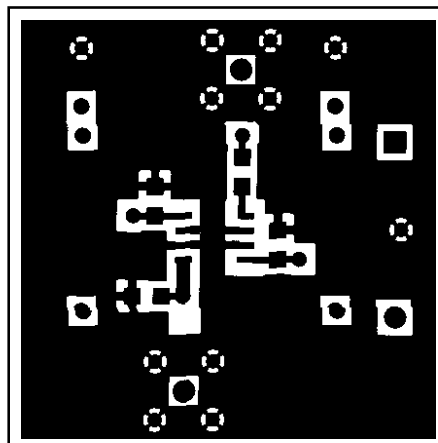

**Figure 6: 730045 Component Side (top) Showing Ground Plane**

### Customer Design Applications Support

National Semiconductor is committed to design excellence. For sales, literature and technical support, call the National Semiconductor Customer Response Group at **1-800-272-9959** or fax **1-800-737-7018**.

### Life Support Policy

National's products are not authorized for use as critical components in life support devices or systems without the express written approval of the president of National Semiconductor Corporation. As used herein:

1. Life support devices or systems are devices or systems which, a) are intended for surgical implant into the body, or b) support or sustain life, and whose failure to perform, when properly used in accordance with instructions for use provided in the labeling, can be reasonably expected to result in a significant injury to the user.
2. A critical component is any component of a life support device or system whose failure to perform can be reasonably expected to cause the failure of the life support device or system, or to affect its safety or effectiveness.



**National Semiconductor Corporation**  
 1111 West Bardin Road  
 Arlington, TX 76017  
 Tel: 1(800) 272-9959  
 Fax: 1(800) 737-7018

**National Semiconductor Europe**  
 Fax: (+49) 0-180-530 85 86  
 E-mail: europe.support.nsc.com  
 Deutsch Tel: (+49) 0-180-530 85 85  
 English Tel: (+49) 0-180-532 78 32  
 Francais Tel: (+49) 0-180-532 93 58  
 Italiano Tel: (+49) 0-180-534 16 80

**National Semiconductor Hong Kong Ltd.**  
 13th Floor, Straight Block  
 Ocean Centre, 5 Canton Road  
 Tsimshatsui, Kowloon  
 Hong Kong  
 Tel: (852) 2737-1600  
 Fax: (852) 2736-9960

**National Semiconductor Japan Ltd.**  
 Tel: 81-043-299-2309  
 Fax: 81-043-299-2408

National does not assume any responsibility for use of any circuitry described, no circuit patent licenses are implied and National reserves the right at any time without notice to change said circuitry and specifications.