

## **Excellent Integrated System Limited**

Stocking Distributor

Click to view price, real time Inventory, Delivery & Lifecycle Information:

[Texas Instruments](#)  
[TLV3492AMDREP](#)

For any questions, you can email us directly:

[sales@integrated-circuit.com](mailto:sales@integrated-circuit.com)

## 1.8 V, NANOPOWER, PUSH/PULL OUTPUT COMPARATORS

### FEATURES

- Very Low Supply Current: 0.8  $\mu$ A (Typical)
- Input Common Mode Range 200 mV Beyond Supply Rails
- Supply Voltage: 1.8 V to 5.5 V
- High Speed: 6  $\mu$ s
- Push/Pull CMOS Output Stage
- Controlled Baseline
  - One Assembly/Test Site, One Fabrication Site
- Extended Temperature Performance of  $-55^{\circ}\text{C}$  to  $125^{\circ}\text{C}$
- Enhanced Diminishing Manufacturing Sources (DMS) Support
- Enhanced Product Change Notification
- Qualification Pedigree

Component qualification in accordance with JEDEC and industry standards to ensure reliable operation over an extended temperature range. This includes, but is not limited to, Highly Accelerated Stress Test (HAST) or biased 85/85, temperature cycle, autoclave or unbiased HAST, electromigration, bond intermetallic life, and mold compound life. Such qualification testing should not be viewed as justifying use of this component beyond specified performance and environmental limits.

### APPLICATIONS

- Portable Medical Equipment
- Wireless Security Systems
- Remote Control Systems
- Handheld Instruments
- Ultra-Low Power Systems

### DESCRIPTION/ORDERING INFORMATION

The TLV349x family of push/pull output comparators features a fast 6 $\mu$ s response time and <1.2  $\mu$ A (max) nanopower capability, allowing operation from 1.8 V to 5.5 V. Input common-mode range beyond supply rails make the TLV349x an ideal choice for low-voltage applications.

The TLV349x is excellent for power-sensitive, low-voltage (2-cell) applications.

#### TLV349x RELATED PRODUCTS

PRODUCT	FEATURES
TLV370x	550 nA, 2.5 V to 16 V, Push-Pull CMOS Output Stage Comparator
TLV340x	550 nA, 2.5 V to 16 V, Open-Drain Output Stage Comparator

### ORDERING INFORMATION<sup>(1)</sup>

PRODUCT	PACKAGE-LEAD	PACKAGE DESIGNATOR <sup>(2)</sup>	SPECIFIED TEMPERATURE RANGE	PACKAGE MARKING	ORDERABLE PART NUMBER	TRANSPORT MEDIA, QUANTITY
TLV3491	SO-8	D	$-55^{\circ}\text{C}$ to $125^{\circ}\text{C}$	3491EP	TLV3491AMDREP <sup>(3)</sup>	Tape and Reel, 2500
TLV3492	SO-8	D	$-55^{\circ}\text{C}$ to $125^{\circ}\text{C}$	3492EP	TLV3492AMDREP	Tape and Reel, 2500
TLV3494	SO-14	D	$-55^{\circ}\text{C}$ to $125^{\circ}\text{C}$	3494EP	TLV3494AMDREP <sup>(3)</sup>	Tape and Reel, 2500

(1) For the most current package and ordering information, see the Package Option Addendum at the end of this document, or see the TI website at [www.ti.com](http://www.ti.com).

(2) Package drawings, thermal data, and symbolization are available at [www.ti.com/packaging](http://www.ti.com/packaging).

(3) Product Preview. Contact your Texas Instruments Sales Representative for availability.



This integrated circuit can be damaged by ESD. Texas Instruments recommends that all integrated circuits be handled with appropriate precautions. Failure to observe proper handling and installation procedures can cause damage.

ESD damage can range from subtle performance degradation to complete device failure. Precision integrated circuits may be more susceptible to damage because very small parametric changes could cause the device not to meet its published specifications.



Please be aware that an important notice concerning availability, standard warranty, and use in critical applications of Texas Instruments semiconductor products and disclaimers thereto appears at the end of this data sheet.

# TLV3491A-EP, TLV3492A-EP, TLV3494A-EP

SGDS035–DECEMBER 2007

## ABSOLUTE MAXIMUM RATINGS<sup>(1)</sup>

		VALUE	UNIT
Supply Voltage		5.5	V
Signal Input Terminals	Voltage <sup>(2)</sup>	(V-) – 0.5 to (V+) + 0.5	V
	Current <sup>(2)</sup>	±10	mA
Output Short-Circuit <sup>(3)</sup>		Continuous	
Operating Temperature		–55 to 125	°C
Storage Temperature		–65 to 150	°C
Junction Temperature		150	°C
Lead Temperature (soldering, 10s)		300	°C
ESD Rating (Human Body Model)		3000	V

- (1) Stresses above these ratings may cause permanent damage. Exposure to absolute maximum conditions for extended periods may degrade device reliability. These are stress ratings only, and functional operation of the device at these or any other conditions beyond those specified is not implied.
- (2) Input terminals are diode clamped to the power-supply rails. Input signals that can swing more than 0.5 V beyond the supply rails should be current limited to 10 mA or less.
- (3) Short-circuit to ground, one amplifier per package.

## PIN CONFIGURATIONS

### Top View

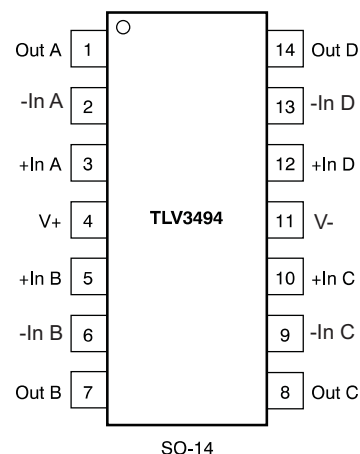
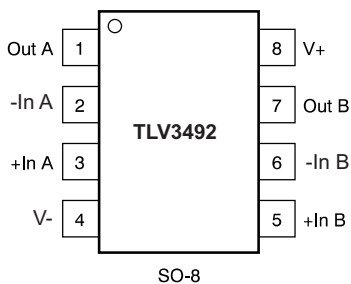
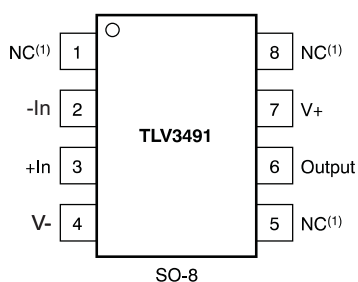

## ELECTRICAL CHARACTERISTICS

At  $T_A = 25^\circ\text{C}$ , and  $V_S = 1.8\text{ V}$  to  $5.5\text{ V}$ , unless otherwise noted.

PARAMETER		TEST CONDITIONS	$T_A^{(1)}$	MIN	TYP	MAX	UNIT
<b>OFFSET VOLTAGE</b>							
Input Offset Voltage	$V_{OS}$	$V_{CM} = 0\text{ V}$ , $I_O = 0\text{ mA}$	25°C		±3	±15	mV
			Full Range			±25	
vs Temperature	$dV_{OS}/dT$	$T_A = -55^\circ\text{C}$ to $125^\circ\text{C}$			±12		$\mu\text{V}/^\circ\text{C}$
vs Power Supply	PSRR	$V_S = 1.8\text{ V}$ to $5.5\text{ V}$	25°C		350	1000	$\mu\text{V}/\text{V}$
			Full Range			1600	
<b>INPUT BIAS CURRENT</b>							
Input Bias Current	$I_B$	$V_{CM} = V_{CC}/2$	25°C		±1	±50	pA
			Full Range			±1600	
Input Offset Current	$I_{OS}$	$V_{CM} = V_{CC}/2$	25°C		±1	±50	pA
			Full Range			±200	
<b>INPUT VOLTAGE RANGE</b>							
Common-Mode Voltage Range	$V_{CM}$			(V-) - 0.2		(V+) + 0.2	V
Common-Mode Rejection Ratio	CMRR	$V_{CM} = -0.2\text{ V}$ to $(V+) - 1.5\text{ V}$	25°C	60	74		dB
			Full Range	55			
		$V_{CM} = -0.2\text{ V}$ to $(V+) + 0.2\text{ V}$	25°C	54	62		
			Full Range	50			
<b>INPUT CAPACITANCE</b>							
Common-Mode					2		pF
Differential					4		pF
<b>SWITCHING CHARACTERISTICS</b>							
Propagation Delay Time, Low-to-High	$t_{PLH}$	$f = 10\text{ kHz}$ , $V_{STEP} = 1\text{ V}$	Input Overdrive = 10 mV		12		$\mu\text{s}$
			Input Overdrive = 100 mV		6		$\mu\text{s}$
Propagation Delay Time, High-to-Low	$t_{PHL}$	$f = 10\text{ kHz}$ , $V_{STEP} = 1\text{ V}$	Input Overdrive = 10 mV		13.5		$\mu\text{s}$
			Input Overdrive = 100 mV		6.5		$\mu\text{s}$
Rise Time	$t_R$	$C_L = 10\text{ pF}$			100		ns
Fall Time	$t_F$	$C_L = 10\text{ pF}$			100		ns
<b>OUTPUT</b>							
Voltage Output High from Rail	$V_{OH}$	$V_S = 5\text{ V}$ , $I_{OUT} = -5\text{ mA}$	Full Range		90	300	mV
Voltage Output Low from Rail	$V_{OL}$	$V_S = 5\text{ V}$ , $I_{OUT} = 5\text{ mA}$	Full Range		160	300	mV
Short-Circuit Current	$I_{SC}$			See Typical Characteristics			
<b>POWER SUPPLY</b>							
Specified Voltage Range	$V_S$			1.8		5.5	V
Quiescent Current <sup>(2)</sup>	$I_Q$	$V_S = 5.5\text{ V}$ , $V_O = \text{High}$	25°C		0.85	1.2	$\mu\text{A}$
			Full Range			2.1	
<b>TEMPERATURE RANGE</b>							
Specified Range	$T_A$			-55		125	°C
Storage Range				-65		150	°C
Thermal Resistance, $\theta_{JA}$							
	SO-8				165		°C/W
	SO-14				133		°C/W

(1) Full Range is  $-55^\circ\text{C}$  to  $125^\circ\text{C}$ .

(2)  $I_Q$  per channel.

**TLV3491A-EP, TLV3492A-EP, TLV3494A-EP**



SGDS035-DECEMBER 2007

**TYPICAL CHARACTERISTICS**

At  $T_A = 25^\circ\text{C}$ ,  $V_S = 1.8\text{ V to }5.5\text{ V}$ , and Input Overdrive = 100 mV, unless otherwise noted.

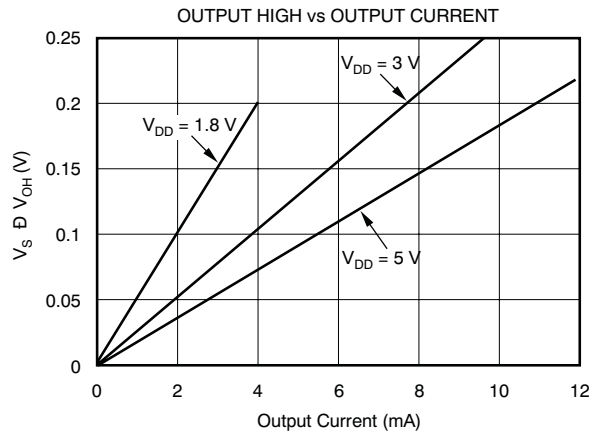
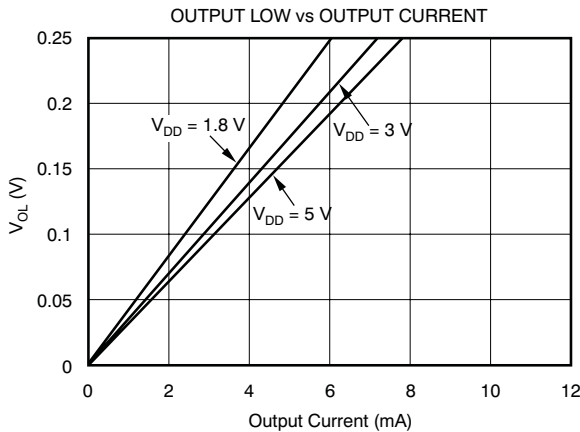
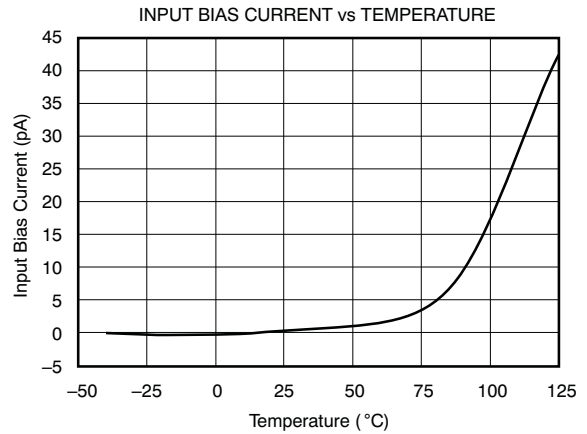
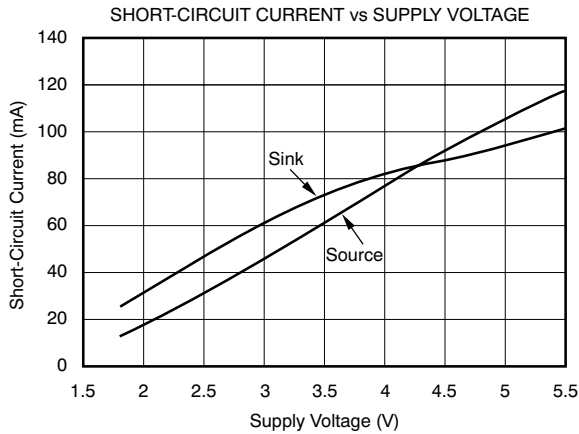
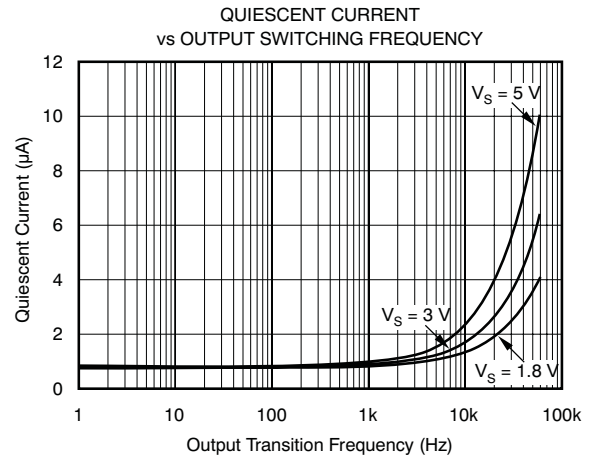
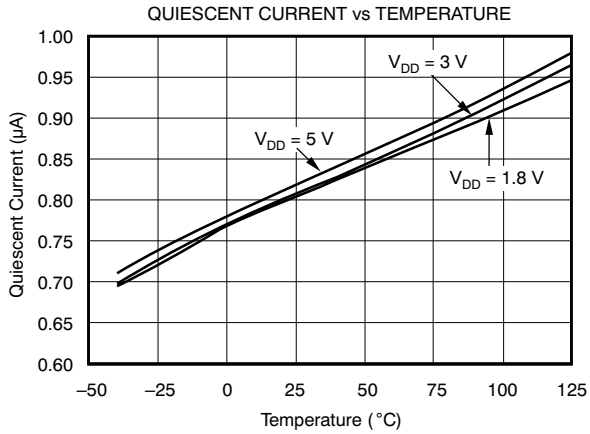

**TYPICAL CHARACTERISTICS (continued)**

At  $T_A = 25^\circ\text{C}$ ,  $V_S = 1.8\text{ V}$  to  $5.5\text{ V}$ , and Input Overdrive =  $100\text{ mV}$ , unless otherwise noted.

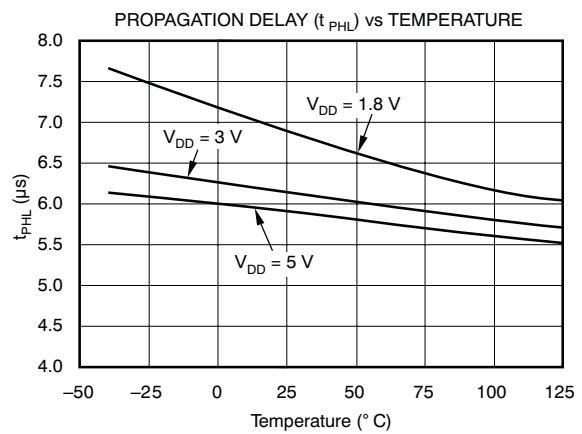
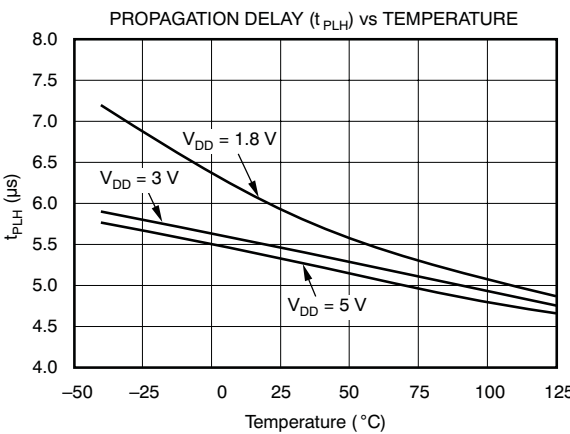
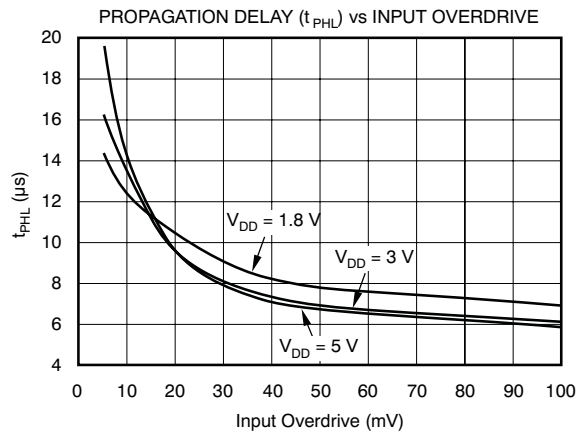
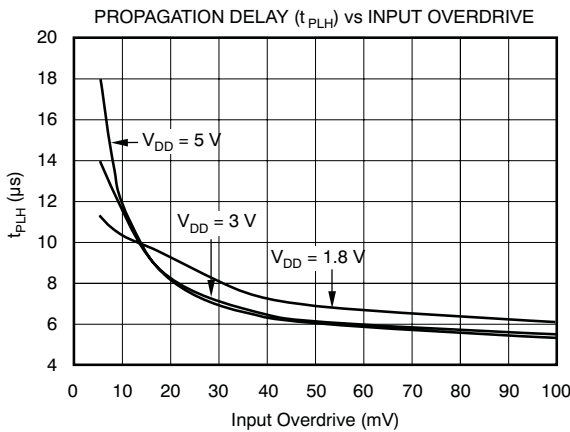
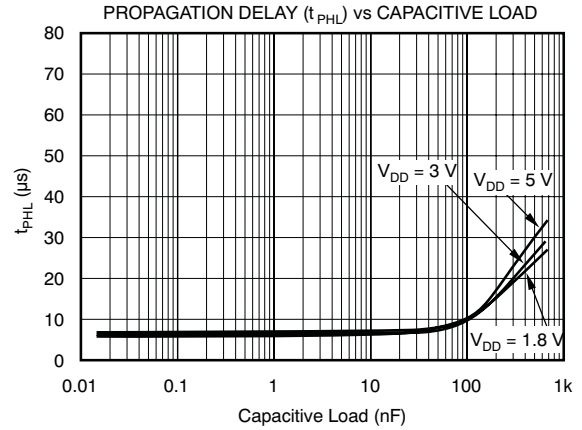
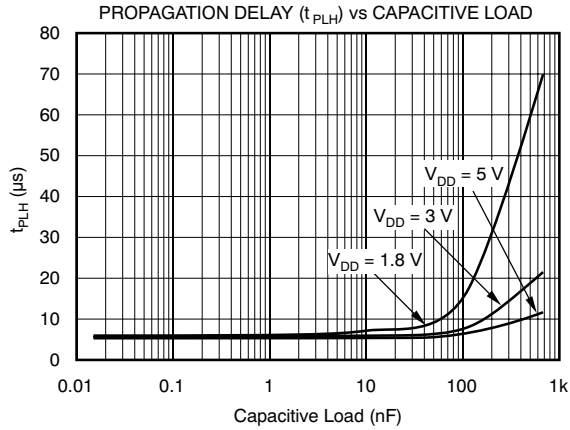

**TLV3491A-EP, TLV3492A-EP, TLV3494A-EP**

SGDS035-DECEMBER 2007

**TYPICAL CHARACTERISTICS (continued)**

At  $T_A = 25^\circ\text{C}$ ,  $V_S = 1.8\text{ V to }5.5\text{ V}$ , and Input Overdrive = 100 mV, unless otherwise noted.

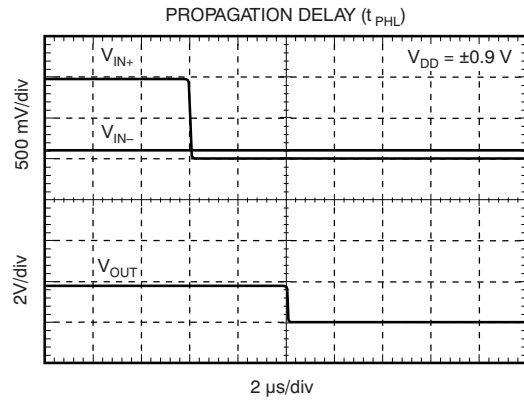
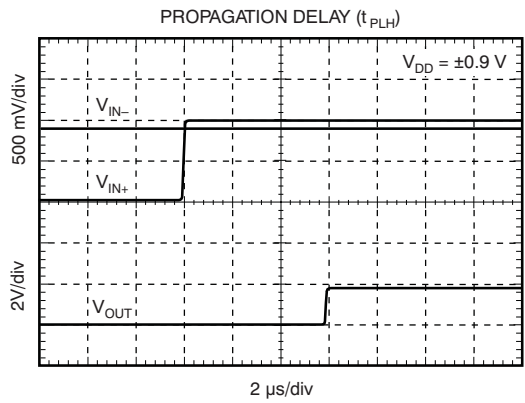
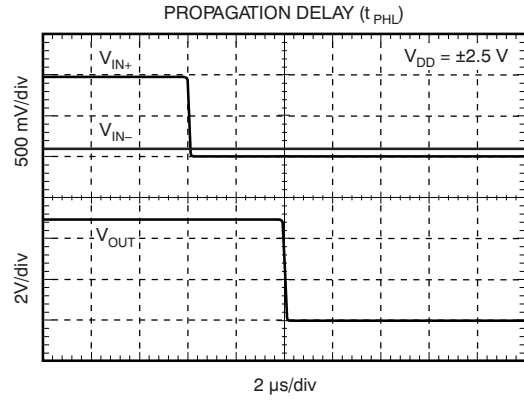
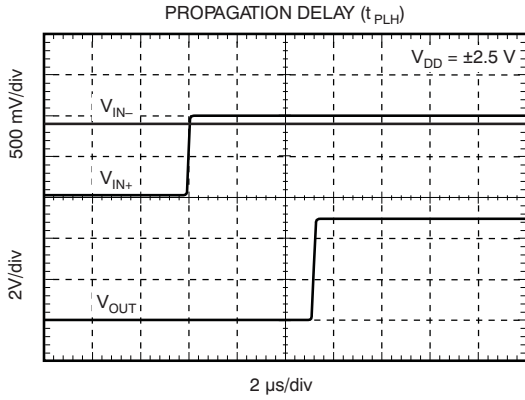

## APPLICATION INFORMATION

The TLV349x family of comparators features rail-to-rail input and output on supply voltages as low as 1.8 V. The push/pull output stage is optimal for reduced power budget applications and features no shoot-through current. Low supply voltages, common-mode input range beyond supply rails, and a typical supply current of 0.8  $\mu$ A make the TLV349x family an excellent candidate for battery-powered applications with single-cell operation.

## BOARD LAYOUT

Figure 1 shows the typical connections for the TLV349x. To minimize supply noise, power supplies should be capacitively decoupled by a 0.01  $\mu$ F ceramic capacitor in parallel with a 10  $\mu$ F electrolytic capacitor. Comparators are very sensitive to input noise. Proper grounding (use of ground plane) will help maintain specified performance of the TLV349x family.

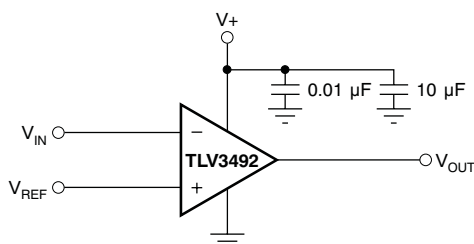

Figure 1. Basic Connections of the TLV3492

## SETTING REFERENCE VOLTAGE

It is important to use a stable reference when setting the transition point for the TLV349x. The REF1004 provides a 1.25-V reference voltage with low drift and only 8  $\mu$ A of quiescent current.

## EXTERNAL HYSTERESIS

Comparator inputs have no noise immunity within the range of specified offset voltage ( $\pm 15$  mV). For noisy input signals, the comparator output may display multiple switching as input signals move through the switching threshold. The typical comparator threshold of the TLV349x is  $\pm 15$  mV. To prevent multiple switching within the comparator threshold of the TLV349x, external hysteresis may be added by connecting a small amount of feedback to the positive input. Figure 2 shows a typical topology used to introduce hysteresis, described by the equation:

$$V_{\text{HYST}} = \frac{V^+ \times R_1}{R_1 + R_2}$$

$V_{\text{HYST}}$  will set the value of the transition voltage required to switch the comparator output by increasing the threshold region, thereby reducing sensitivity to noise.

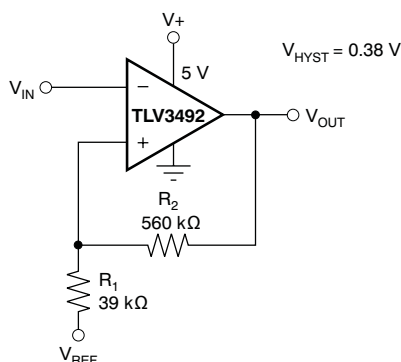

Figure 2. Adding Hysteresis to the TLV3492



**TLV3491A-EP, TLV3492A-EP, TLV3494A-EP**

SGDS035-DECEMBER 2007

**RELAXATION OSCILLATOR**

The TLV3492 can be configured as a relaxation oscillator to provide a simple and inexpensive clock output (see Figure 3). The capacitor is charged at a rate of  $0.69 RC$ . It also discharges at a rate of  $0.69 RC$ . Therefore, the period is  $1.38 RC$ .  $R_1$  may be a different value than  $R_2$ .

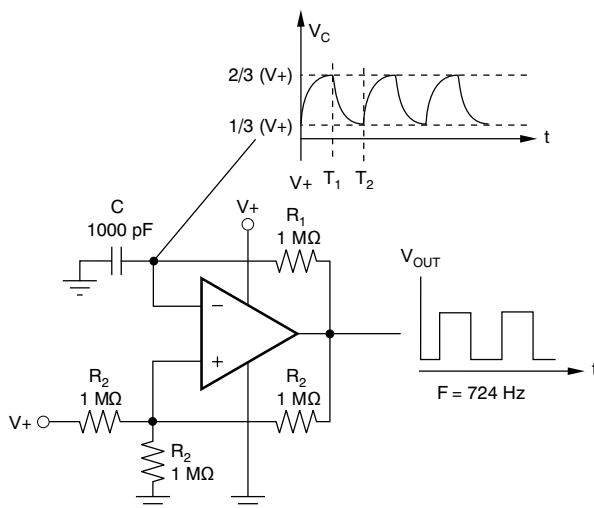

**Figure 3. TLV3492 Configured as a Relaxation Oscillator**

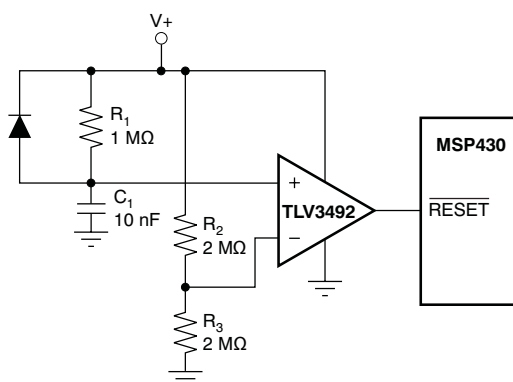

**POWER-ON RESET**

The reset circuit shown in Figure 4 provides a time delayed release of reset to the MSP430 microcontroller. Operation of the circuit is based on a stabilization time constant of the supply voltage, rather than on a predetermined voltage value. The negative input is a reference voltage created by a simple resistor divider. These resistor values should be relatively high to reduce the current consumption of the circuit. The positive input is an RC circuit that provides a power-up delay. When power is applied, the output of the comparator is low, holding the processor in the reset condition. Only after allowing time for the supply voltage to stabilize does the positive input of the comparator become higher than the negative input, resulting in a high output state and releasing the processor for operation. The stabilization time required for the supply voltage is adjustable by the selection of the RC component values. Use of a lower-valued resistor in this portion of the circuit will not increase current consumption because no current flows through the RC circuit after the supply has stabilized. The reset delay time needed depends on the power-up characteristics of the system power supply.  $R_1$  and  $C_1$  are selected to allow enough time for the power supply to stabilize. D1 provides rapid reset if power is lost. In this example, the  $R_1 \cdot C_1$  time constant is 10 ms.



**Figure 4. The TLV349x Configured as a Reset Circuit for the MSP430.**

**PACKAGING INFORMATION**

Orderable Device	Status (1)	Package Type	Package Drawing	Pins	Package Qty	Eco Plan (2)	Lead/Ball Finish (6)	MSL Peak Temp (3)	Op Temp (°C)	Device Marking (4/5)	Samples
TLV3492AMDREP	ACTIVE	SOIC	D	8	2500	Green (RoHS & no Sb/Br)	CU NIPDAU	Level-1-260C-UNLIM	-55 to 125	3492EP	
V62/07635-01XE	ACTIVE	SOIC	D	8	2500	Green (RoHS & no Sb/Br)	CU NIPDAU	Level-1-260C-UNLIM	-55 to 125	3492EP	

(1) The marketing status values are defined as follows:

**ACTIVE:** Product device recommended for new designs.

**LIFEBUY:** TI has announced that the device will be discontinued, and a lifetime-buy period is in effect.

**NRND:** Not recommended for new designs. Device is in production to support existing customers, but TI does not recommend using this part in a new design.

**PREVIEW:** Device has been announced but is not in production. Samples may or may not be available.

**OBSELETE:** TI has discontinued the production of the device.

(2) Eco Plan - The planned eco-friendly classification: Pb-Free (RoHS), Pb-Free (RoHS Exempt), or Green (RoHS & no Sb/Br) - please check <http://www.ti.com/productcontent> for the latest availability information and additional product content details.

**TBD:** The Pb-Free/Green conversion plan has not been defined.

**Pb-Free (RoHS):** TI's terms "Lead-Free" or "Pb-Free" mean semiconductor products that are compatible with the current RoHS requirements for all 6 substances, including the requirement that lead not exceed 0.1% by weight in homogeneous materials. Where designed to be soldered at high temperatures, TI Pb-Free products are suitable for use in specified lead-free processes.

**Pb-Free (RoHS Exempt):** This component has a RoHS exemption for either 1) lead-based flip-chip solder bumps used between the die and package, or 2) lead-based die adhesive used between the die and leadframe. The component is otherwise considered Pb-Free (RoHS compatible) as defined above.

**Green (RoHS & no Sb/Br):** TI defines "Green" to mean Pb-Free (RoHS compatible), and free of Bromine (Br) and Antimony (Sb) based flame retardants (Br or Sb do not exceed 0.1% by weight in homogeneous material)

(3) MSL, Peak Temp. - The Moisture Sensitivity Level rating according to the JEDEC industry standard classifications, and peak solder temperature.

(4) There may be additional marking, which relates to the logo, the lot trace code information, or the environmental category on the device.

(5) Multiple Device Markings will be inside parentheses. Only one Device Marking contained in parentheses and separated by a "-" will appear on a device. If a line is indented then it is a continuation of the previous line and the two combined represent the entire Device Marking for that device.

(6) Lead/Ball Finish - Orderable Devices may have multiple material finish options. Finish options are separated by a vertical ruled line. Lead/Ball Finish values may wrap to two lines if the finish value exceeds the maximum column width.

**Important Information and Disclaimer:** The information provided on this page represents TI's knowledge and belief as of the date that it is provided. TI bases its knowledge and belief on information provided by third parties, and makes no representation or warranty as to the accuracy of such information. Efforts are underway to better integrate information from third parties. TI has taken and continues to take reasonable steps to provide representative and accurate information but may not have conducted destructive testing or chemical analysis on incoming materials and chemicals. TI and TI suppliers consider certain information to be proprietary, and thus CAS numbers and other limited information may not be available for release.



**Distributor of Texas Instruments: Excellent Integrated System Limited**

Datasheet of TLV3492AMDREP - IC COMPARATOR 1.8V PP OUT 8-SOIC

Contact us: [sales@integrated-circuit.com](mailto:sales@integrated-circuit.com) Website: [www.integrated-circuit.com](http://www.integrated-circuit.com)

**PACKAGE OPTION ADDENDUM**

---



[www.ti.com](http://www.ti.com)

31-May-2014

---

In no event shall TI's liability arising out of such information exceed the total purchase price of the TI part(s) at issue in this document sold by TI to Customer on an annual basis.

**TAPE AND REEL INFORMATION**

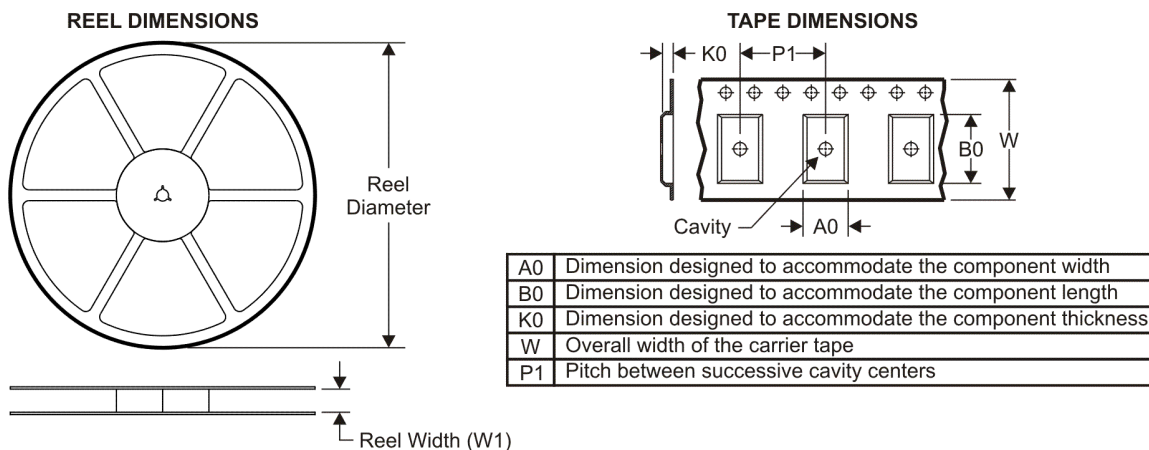

**QUADRANT ASSIGNMENTS FOR PIN 1 ORIENTATION IN TAPE**

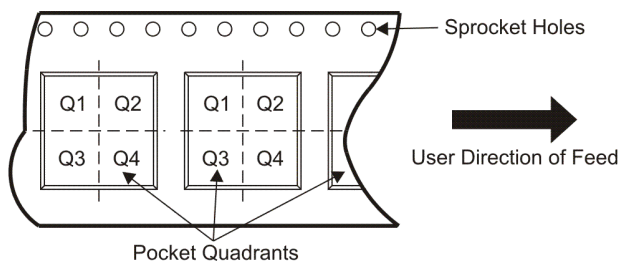

\*All dimensions are nominal

Device	Package Type	Package Drawing	Pins	SPQ	Reel Diameter (mm)	Reel Width W1 (mm)	A0 (mm)	B0 (mm)	K0 (mm)	P1 (mm)	W (mm)	Pin1 Quadrant
TLV3492AMDREP	SOIC	D	8	2500	330.0	12.4	6.4	5.2	2.1	8.0	12.0	Q1

**TAPE AND REEL BOX DIMENSIONS**

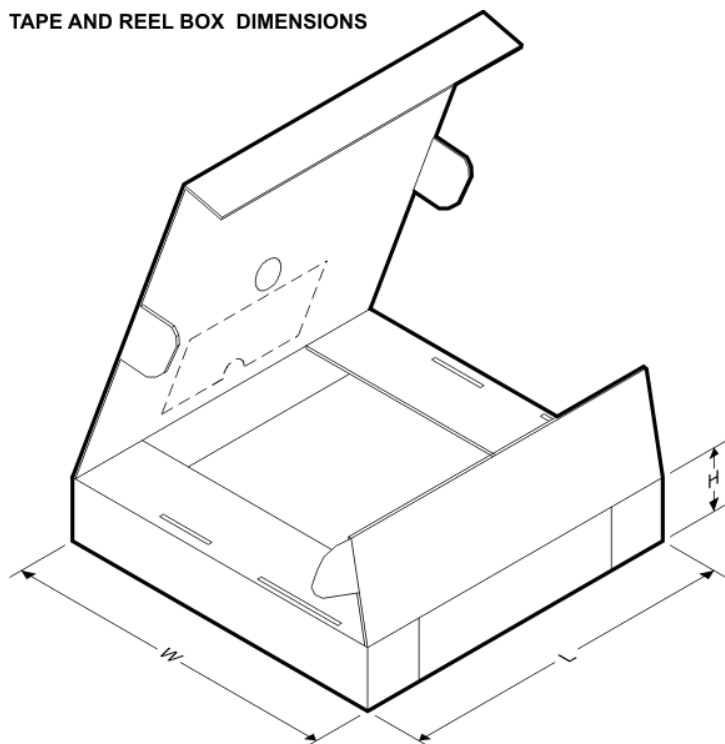

\*All dimensions are nominal

Device	Package Type	Package Drawing	Pins	SPQ	Length (mm)	Width (mm)	Height (mm)
TLV3492AMDREP	SOIC	D	8	2500	340.5	338.1	20.6

**MECHANICAL DATA**

D (R-PDSO-G8)

PLASTIC SMALL OUTLINE

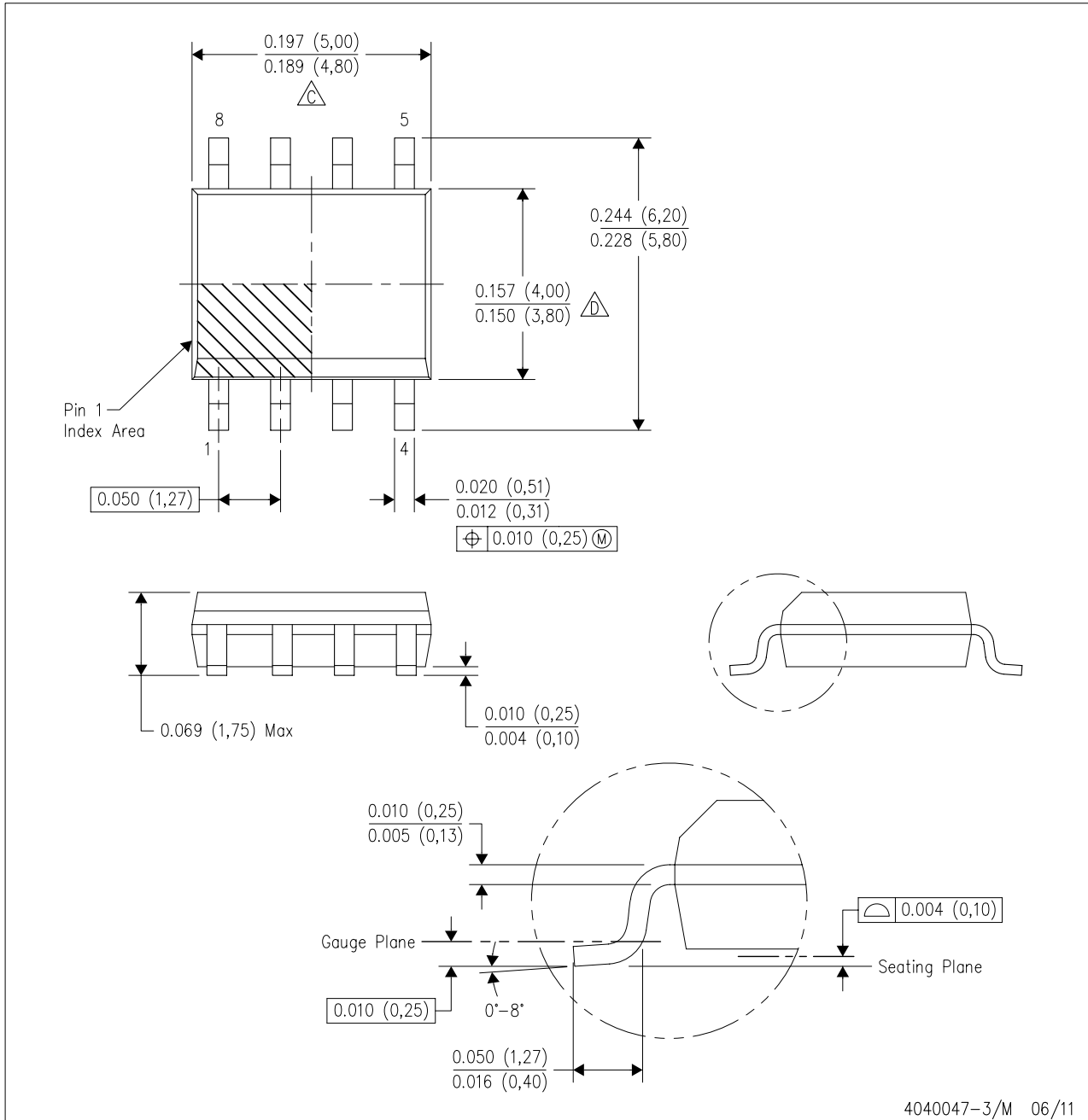

4040047-3/M 06/11

- NOTES:
- A. All linear dimensions are in inches (millimeters).
  - B. This drawing is subject to change without notice.
  - $\triangle C$  Body length does not include mold flash, protrusions, or gate burrs. Mold flash, protrusions, or gate burrs shall not exceed 0.006 (0,15) each side.
  - $\triangle D$  Body width does not include interlead flash. Interlead flash shall not exceed 0.017 (0,43) each side.
  - E. Reference JEDEC MS-012 variation AA.

**LAND PATTERN DATA**

D (R-PDSO-G8)

PLASTIC SMALL OUTLINE

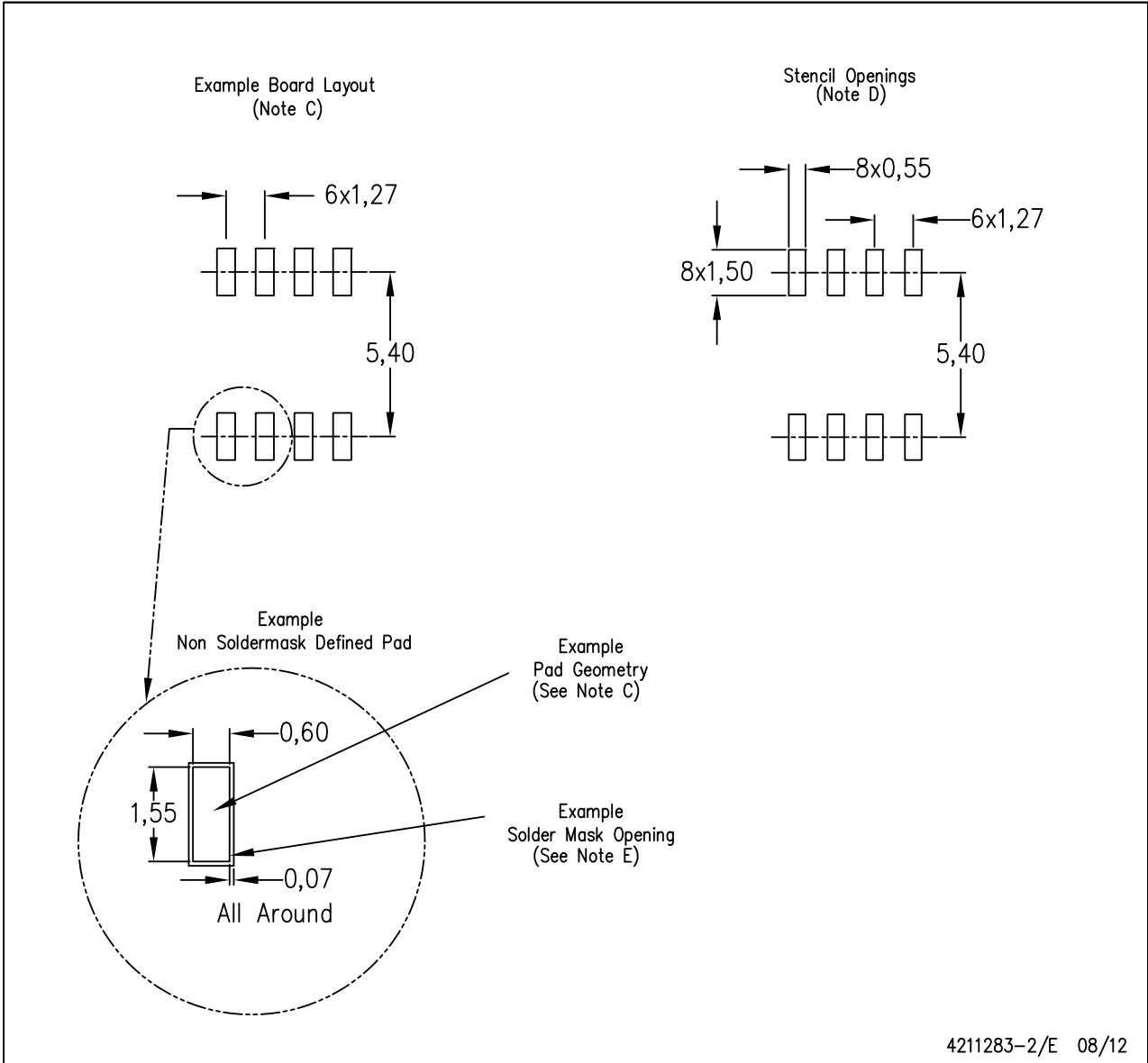

- NOTES:
- A. All linear dimensions are in millimeters.
  - B. This drawing is subject to change without notice.
  - C. Publication IPC-7351 is recommended for alternate designs.
  - D. Laser cutting apertures with trapezoidal walls and also rounding corners will offer better paste release. Customers should contact their board assembly site for stencil design recommendations. Refer to IPC-7525 for other stencil recommendations.
  - E. Customers should contact their board fabrication site for solder mask tolerances between and around signal pads.

### IMPORTANT NOTICE

Texas Instruments Incorporated and its subsidiaries (TI) reserve the right to make corrections, enhancements, improvements and other changes to its semiconductor products and services per JESD46, latest issue, and to discontinue any product or service per JESD48, latest issue. Buyers should obtain the latest relevant information before placing orders and should verify that such information is current and complete. All semiconductor products (also referred to herein as "components") are sold subject to TI's terms and conditions of sale supplied at the time of order acknowledgment.

TI warrants performance of its components to the specifications applicable at the time of sale, in accordance with the warranty in TI's terms and conditions of sale of semiconductor products. Testing and other quality control techniques are used to the extent TI deems necessary to support this warranty. Except where mandated by applicable law, testing of all parameters of each component is not necessarily performed.

TI assumes no liability for applications assistance or the design of Buyers' products. Buyers are responsible for their products and applications using TI components. To minimize the risks associated with Buyers' products and applications, Buyers should provide adequate design and operating safeguards.

TI does not warrant or represent that any license, either express or implied, is granted under any patent right, copyright, mask work right, or other intellectual property right relating to any combination, machine, or process in which TI components or services are used. Information published by TI regarding third-party products or services does not constitute a license to use such products or services or a warranty or endorsement thereof. Use of such information may require a license from a third party under the patents or other intellectual property of the third party, or a license from TI under the patents or other intellectual property of TI.

Reproduction of significant portions of TI information in TI data books or data sheets is permissible only if reproduction is without alteration and is accompanied by all associated warranties, conditions, limitations, and notices. TI is not responsible or liable for such altered documentation. Information of third parties may be subject to additional restrictions.

Resale of TI components or services with statements different from or beyond the parameters stated by TI for that component or service voids all express and any implied warranties for the associated TI component or service and is an unfair and deceptive business practice. TI is not responsible or liable for any such statements.

Buyer acknowledges and agrees that it is solely responsible for compliance with all legal, regulatory and safety-related requirements concerning its products, and any use of TI components in its applications, notwithstanding any applications-related information or support that may be provided by TI. Buyer represents and agrees that it has all the necessary expertise to create and implement safeguards which anticipate dangerous consequences of failures, monitor failures and their consequences, lessen the likelihood of failures that might cause harm and take appropriate remedial actions. Buyer will fully indemnify TI and its representatives against any damages arising out of the use of any TI components in safety-critical applications.

In some cases, TI components may be promoted specifically to facilitate safety-related applications. With such components, TI's goal is to help enable customers to design and create their own end-product solutions that meet applicable functional safety standards and requirements. Nonetheless, such components are subject to these terms.

No TI components are authorized for use in FDA Class III (or similar life-critical medical equipment) unless authorized officers of the parties have executed a special agreement specifically governing such use.

Only those TI components which TI has specifically designated as military grade or "enhanced plastic" are designed and intended for use in military/aerospace applications or environments. Buyer acknowledges and agrees that any military or aerospace use of TI components which have **not** been so designated is solely at the Buyer's risk, and that Buyer is solely responsible for compliance with all legal and regulatory requirements in connection with such use.

TI has specifically designated certain components as meeting ISO/TS16949 requirements, mainly for automotive use. In any case of use of non-designated products, TI will not be responsible for any failure to meet ISO/TS16949.

#### Products

Audio	<a href="http://www.ti.com/audio">www.ti.com/audio</a>
Amplifiers	<a href="http://amplifier.ti.com">amplifier.ti.com</a>
Data Converters	<a href="http://dataconverter.ti.com">dataconverter.ti.com</a>
DLP® Products	<a href="http://www.dlp.com">www.dlp.com</a>
DSP	<a href="http://dsp.ti.com">dsp.ti.com</a>
Clocks and Timers	<a href="http://www.ti.com/clocks">www.ti.com/clocks</a>
Interface	<a href="http://interface.ti.com">interface.ti.com</a>
Logic	<a href="http://logic.ti.com">logic.ti.com</a>
Power Mgmt	<a href="http://power.ti.com">power.ti.com</a>
Microcontrollers	<a href="http://microcontroller.ti.com">microcontroller.ti.com</a>
RFID	<a href="http://www.ti-rfid.com">www.ti-rfid.com</a>
OMAP Applications Processors	<a href="http://www.ti.com/omap">www.ti.com/omap</a>
Wireless Connectivity	<a href="http://www.ti.com/wirelessconnectivity">www.ti.com/wirelessconnectivity</a>

#### Applications

Automotive and Transportation	<a href="http://www.ti.com/automotive">www.ti.com/automotive</a>
Communications and Telecom	<a href="http://www.ti.com/communications">www.ti.com/communications</a>
Computers and Peripherals	<a href="http://www.ti.com/computers">www.ti.com/computers</a>
Consumer Electronics	<a href="http://www.ti.com/consumer-apps">www.ti.com/consumer-apps</a>
Energy and Lighting	<a href="http://www.ti.com/energy">www.ti.com/energy</a>
Industrial	<a href="http://www.ti.com/industrial">www.ti.com/industrial</a>
Medical	<a href="http://www.ti.com/medical">www.ti.com/medical</a>
Security	<a href="http://www.ti.com/security">www.ti.com/security</a>
Space, Avionics and Defense	<a href="http://www.ti.com/space-avionics-defense">www.ti.com/space-avionics-defense</a>
Video and Imaging	<a href="http://www.ti.com/video">www.ti.com/video</a>

#### TI E2E Community

[e2e.ti.com](http://e2e.ti.com)