

Excellent Integrated System Limited

Stocking Distributor

Click to view price, real time Inventory, Delivery & Lifecycle Information:

[E-Switch](#)
[300DP1R8WHTM1QE](#)

For any questions, you can email us directly:

sales@integrated-circuit.com

SHEET OF

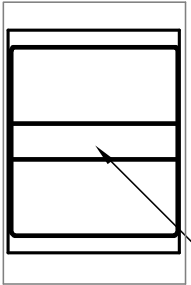

WHITE ROCKER
 R. 0.13 (4 PL)

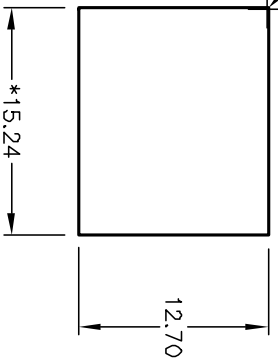

RECOMMENDED PANEL MOUNTING

PANEL THICKNESS
 1.52 TD 3.18
 * DIMENSION IS 15.75/15.88
 FOR PANEL THICKNESS BETWEEN
 1.52mm TD 3.18mm

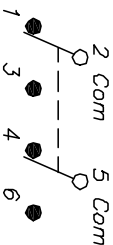

CIRCUIT: DPDT

SWITCH FUNCTION		
POS. 1	POS. 2	POS. 3
DN	NONE	DN
2-3,5-6	DPEN	2-1,5-4

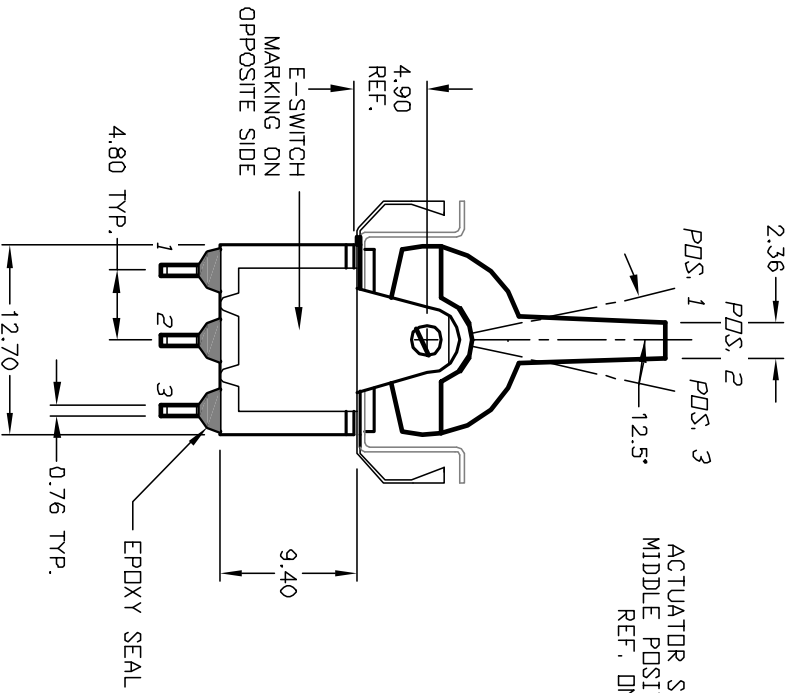

ACTUATOR SHOWN IN MIDDLE POSITION FOR REF. ONLY

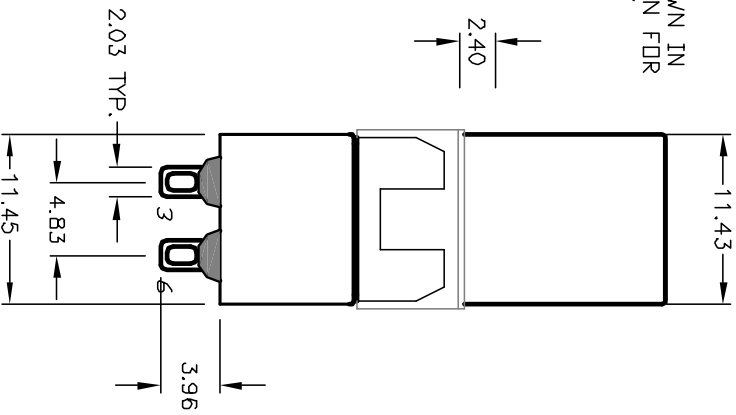

NOTES:

1. ALL DIMENSIONS IN MM
2. GENERAL TOLERANCE: X.XX=±0.4 X.XX=±0.25
3. TERM. NOS. FOR REF. ONLY
4. RATING: 5A @120VAC OR 2BVDC 2A @250VAC
5. MATERIAL: FIXED TERMINAL & MOVING CONTACT Copper Alloy w/Silver Plate
6. CONTACT RESISTANCE: 10mILLI Ohms max initial @2-4VDC, 100mA for AG & AU
7. ELECTRICAL LIFE: 50,000 make-and-break cycles at full load.
8. INSULATION RESISTANCE: 1,000M Ohm min.
9. DIELECTRIC STRENGTH: 1000V RMS @sea level
10. OPERATING TEMP.: -30°C to 85°C

E-SWITCH®

REV. A	12446	RELEASED FOR PRODUCTION	9/25/02	CB
ECN No.		DESCRIPTION	DATE	CHKD

TITLE	300 DP-1 R8 WHT M1 Q E	SCALE	2:1	DATE	9/25/02	DR	CB	DWG	T321063	REV	A
-------	------------------------	-------	-----	------	---------	----	----	-----	---------	-----	---

THE INFORMATION CONTAINED IN THIS DOCUMENT IS PROPRIETARY TO E-SWITCH AND IS NOT TO BE COPIED OR TRANSMITTED